



US00D333648S

United States Patent [19]

[11] Patent Number: **Des. 333,648**

Schwenk

[45] Date of Patent: **** Mar. 2, 1993**

[54] **VEHICLE WHEEL**

[75] Inventor: **Franz Schwenk**, Alpirsbach, Fed. Rep. of Germany

[73] Assignee: **BBS Kraftfahrzeugtechnik Aktiengesellschaft**, Fed. Rep. of Germany

[**] Term: **14 Years**

[21] Appl. No.: **495,301**

[22] Filed: **Mar. 19, 1990**

[52] U.S. Cl. **D12/209**

[58] Field of Search **D12/209, 211; 301/64 R, 301/64 SD, 65**

Road & Track, May 1989, p. 104, Ferrari Testarossa Wheel, lower left side of page.

Tire Review, Feb. 1989, p. 35, BBS Wheel, lower center of page.

Modern Tire Dealer, Nov. 1989, p. 46, CSI Wheel, center of page.

2 pages and back cover of ENKEI Catalog published Aug. 1986, one page showing EK 80 wheel and the other page showing Majesty, CT-7 and CT-8 wheels.

Inside cover and page of Cragar Catalog published 1985 showing S/S Super Sport wheel.

Cover and pages from Cragar 1989 New Product Catalog Supplement showing Street Star, Drag Star "Vette" Special Edition and Drag Star 16" Camaro/Firebird Special Edition wheels.

Primary Examiner—James M. Gandy

Attorney, Agent, or Firm—Dick and Harris

[56] **References Cited**

U.S. PATENT DOCUMENTS

D. 248,551 7/1978 Sekido et al. D12/211

D. 284,000 5/1986 Braungart D12/211

OTHER PUBLICATIONS

Road & Track, Feb. 1989, p. 163, Audi Wheel, center of page.

[57] **CLAIM**

The ornamental design for vehicle wheel, as shown.

DESCRIPTION

FIG. 1 is a perspective view of the vehicle wheel showing the new ornamental design;

FIG. 2 is a side elevational view thereof;

FIG. 3 is a front elevational view thereof; and,

FIG. 4 is a rear elevational view thereof.

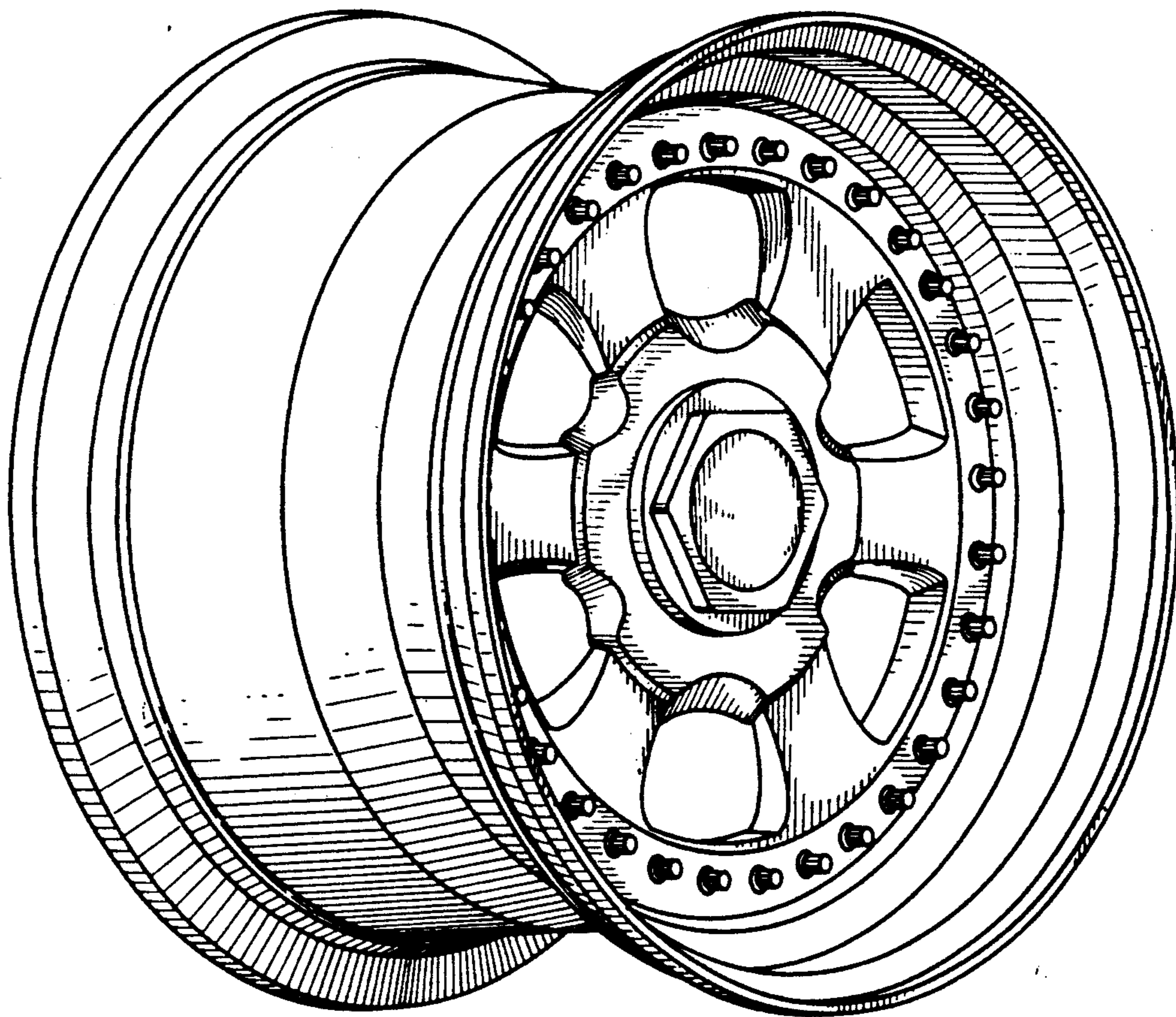

Fig 1

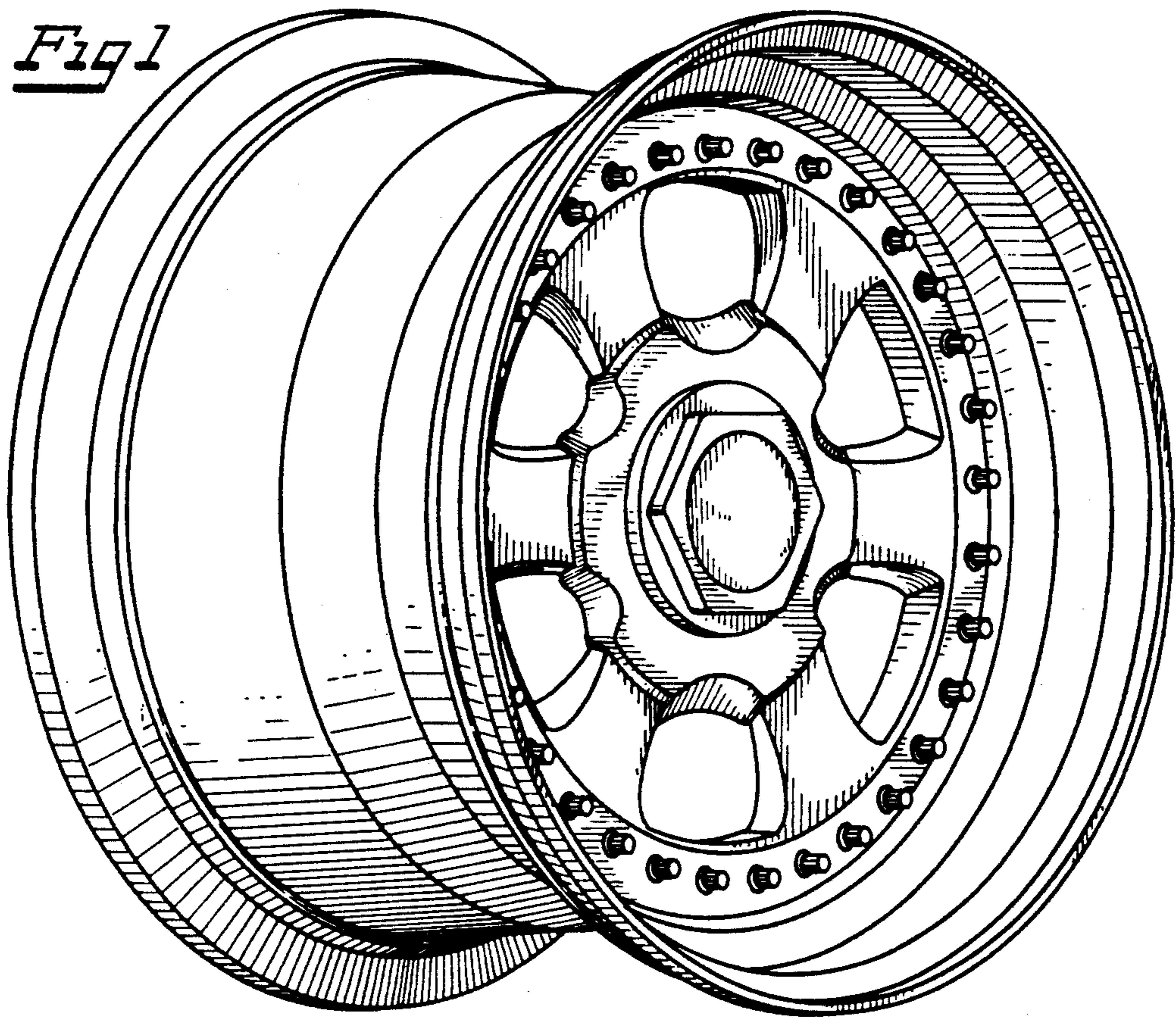

Fig 2

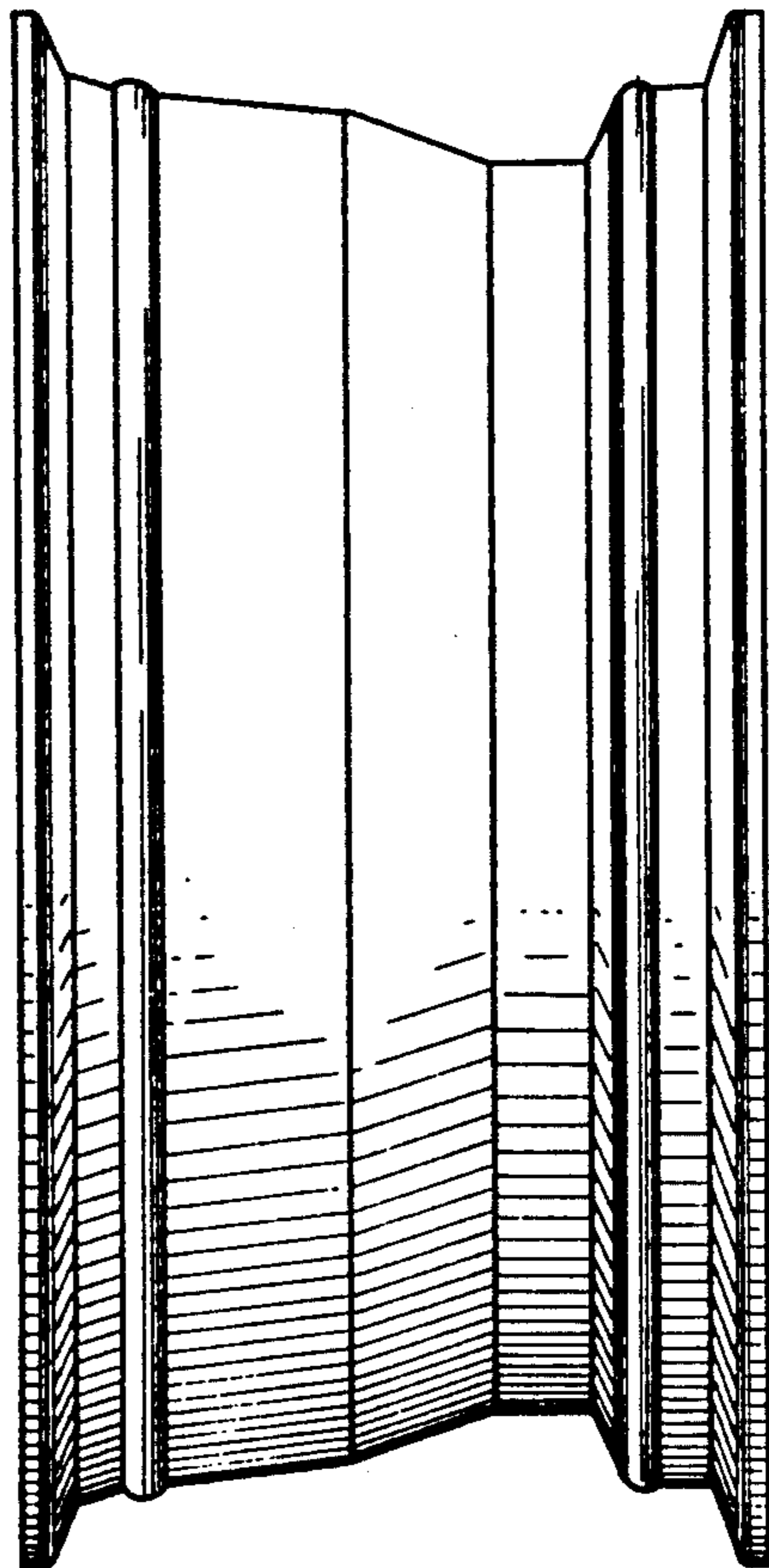

Fig 3

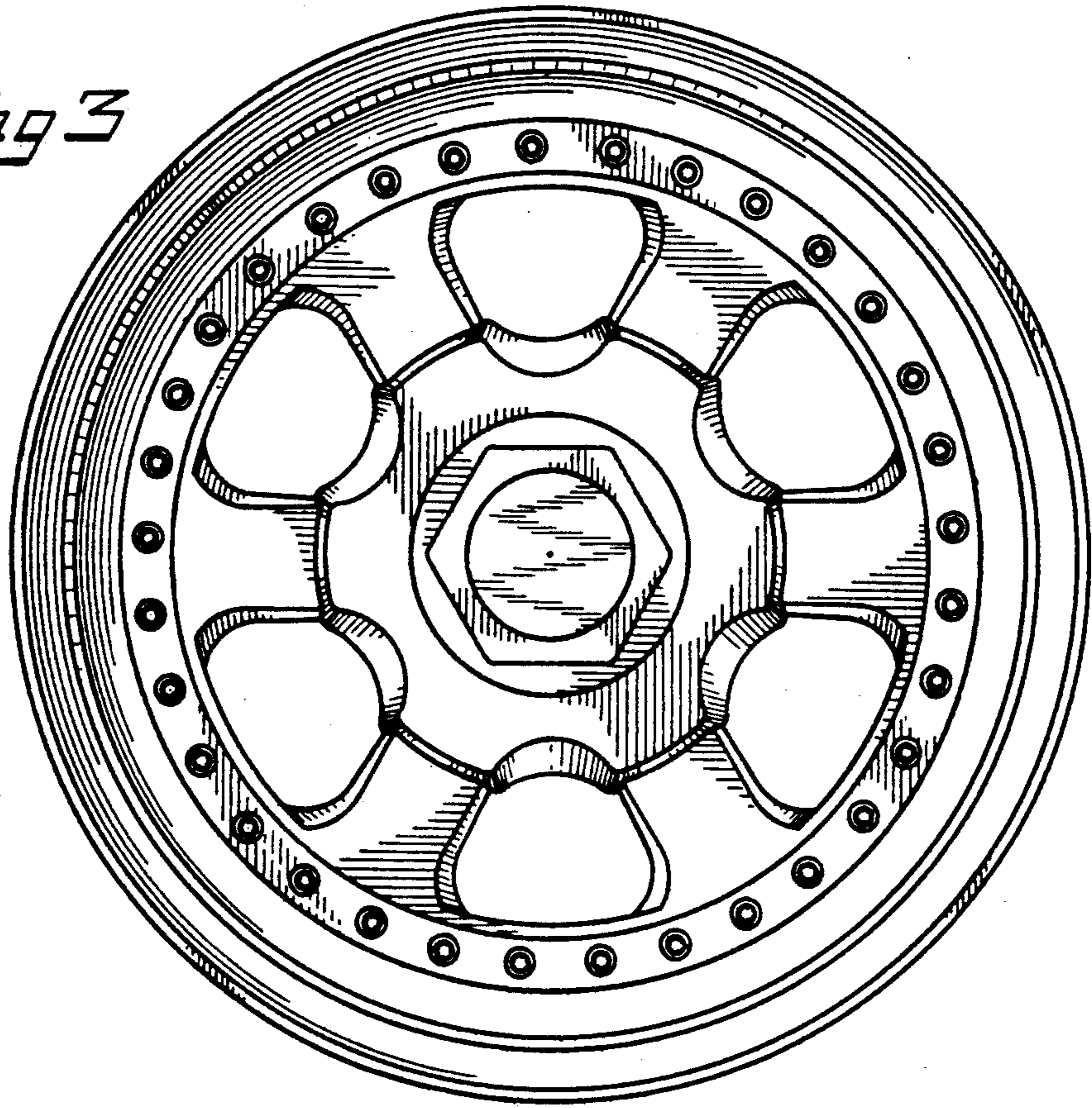

Fig 4

