



US00D333584S

United States Patent [19]

[11] Patent Number: **Des. 333,584**

Starr, IV

[45] Date of Patent: **** Mar. 2, 1993**

[54] SHELF

4,863,130 9/1989 Marks, Jr. 248/206.3

[76] Inventor: **Harry W. Starr, IV**, 215 Clearwater, Plainview, Ill. 62676

Primary Examiner—Brian N. Vinson
Attorney, Agent, or Firm—Brady, O'Boyle & Gates

[**] Term: **14 Years**

[57] **CLAIM**

[21] Appl. No.: **556,794**

The ornamental design for a shelf, as shown and described.

[22] Filed: **Jul. 23, 1990**

DESCRIPTION

[52] U.S. Cl. **D6/574**

FIG. 1 is a top, front, and left side perspective view of a shelf showing my new design;

[58] Field of Search **D6/553, 567, 574;**
211/13, 41-42, 71, 86-88, 90, 126, 134;
248/205.5, 206.2, 206.4

FIG. 2 is a front elevational view thereof;

FIG. 3 is a rear elevational view thereof;

FIG. 4 is a left side elevational view thereof, the right side being a mirror image of that shown;

FIG. 5 is a top plan view thereof;

FIG. 6 is a bottom plan view thereof; and,

FIG. 7 is a top, front, and left side perspective view of a second embodiment thereof, the only difference residing in the number of suction cup support elements.

[56] **References Cited**

U.S. PATENT DOCUMENTS

- D. 197,871 3/1964 Crisp D6/566
- D. 224,198 7/1972 Hastings D6/475 X
- D. 291,176 8/1987 Sokol D6/574 X
- D. 296,520 7/1988 Spinetta D6/553 X

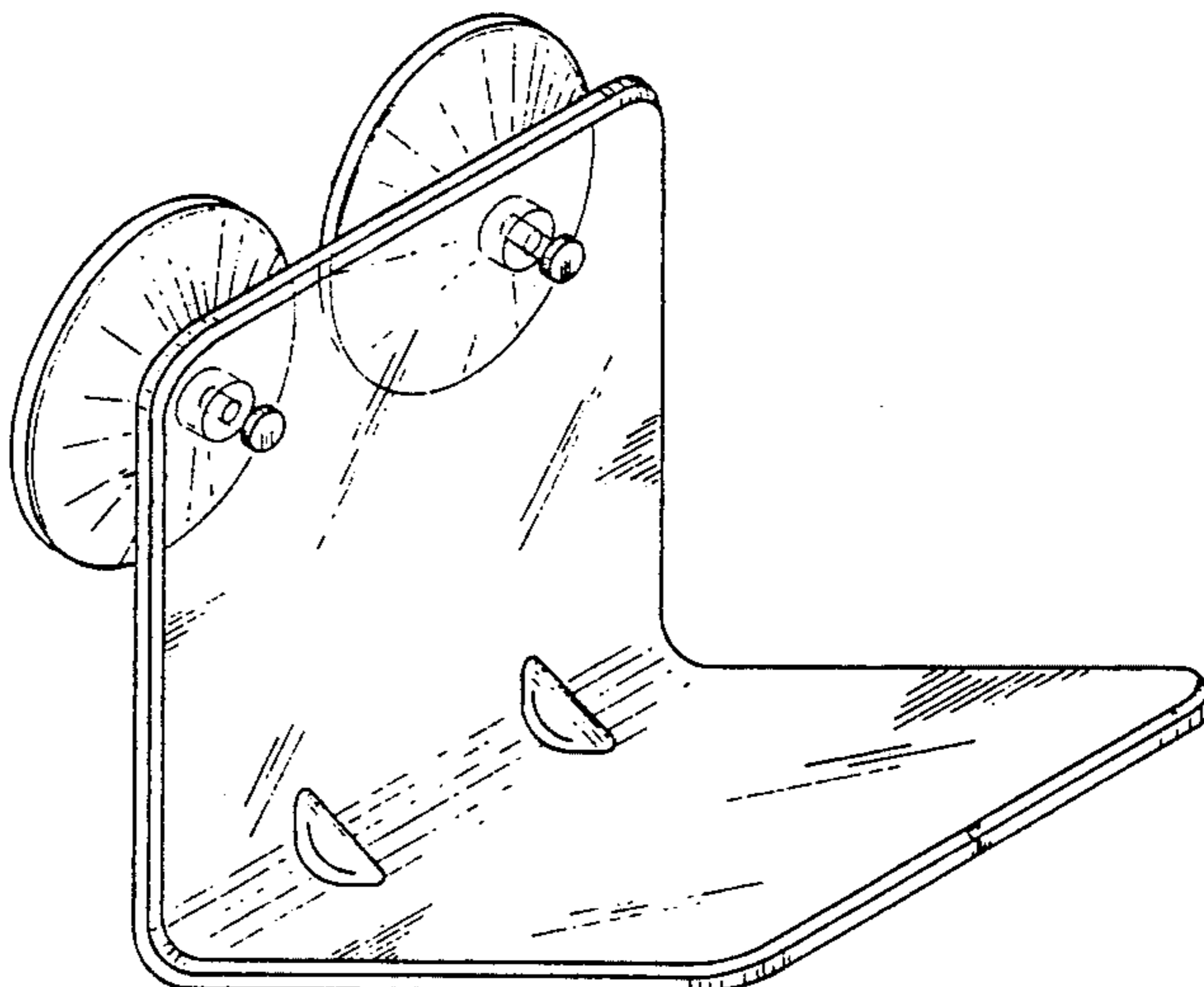
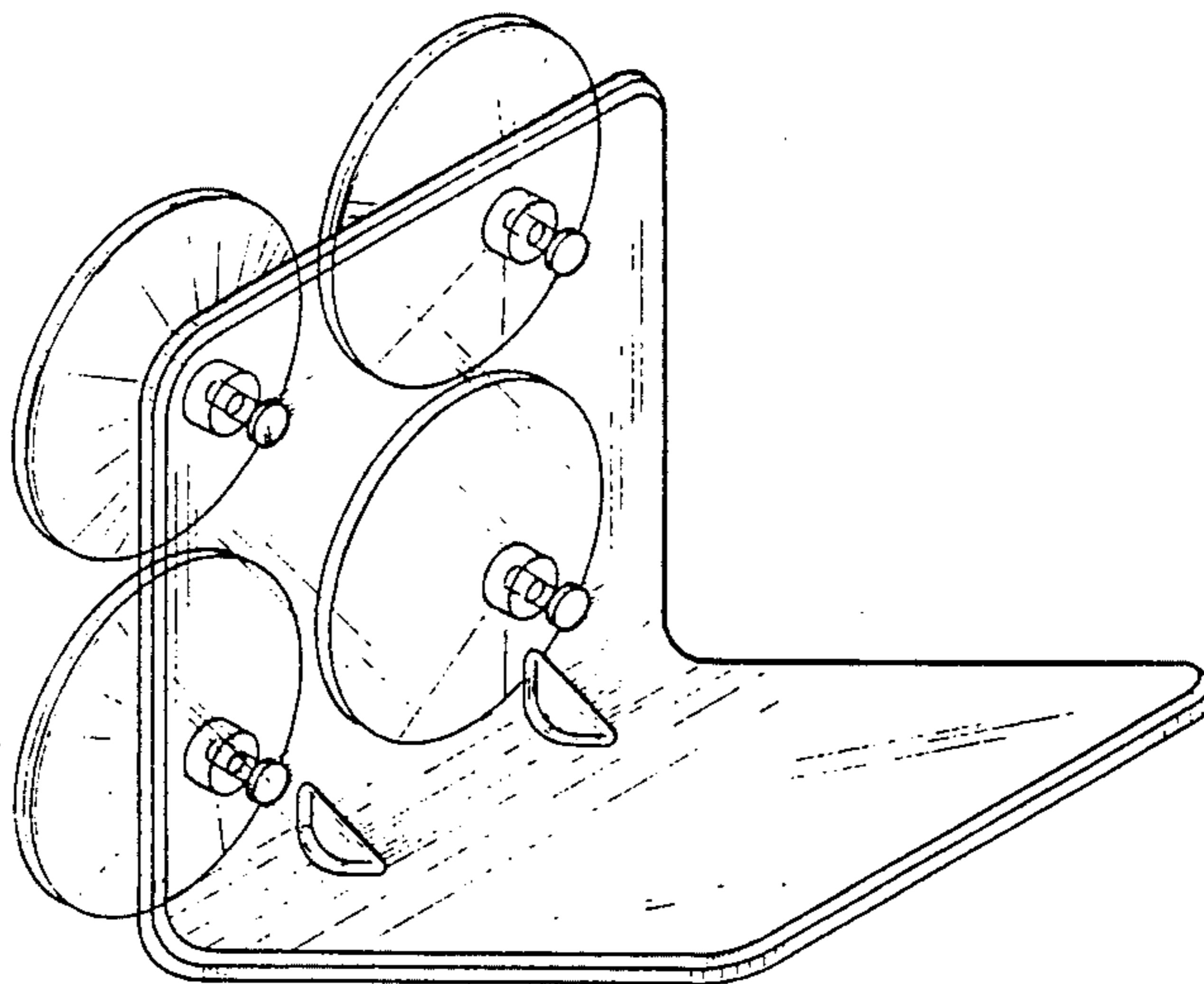

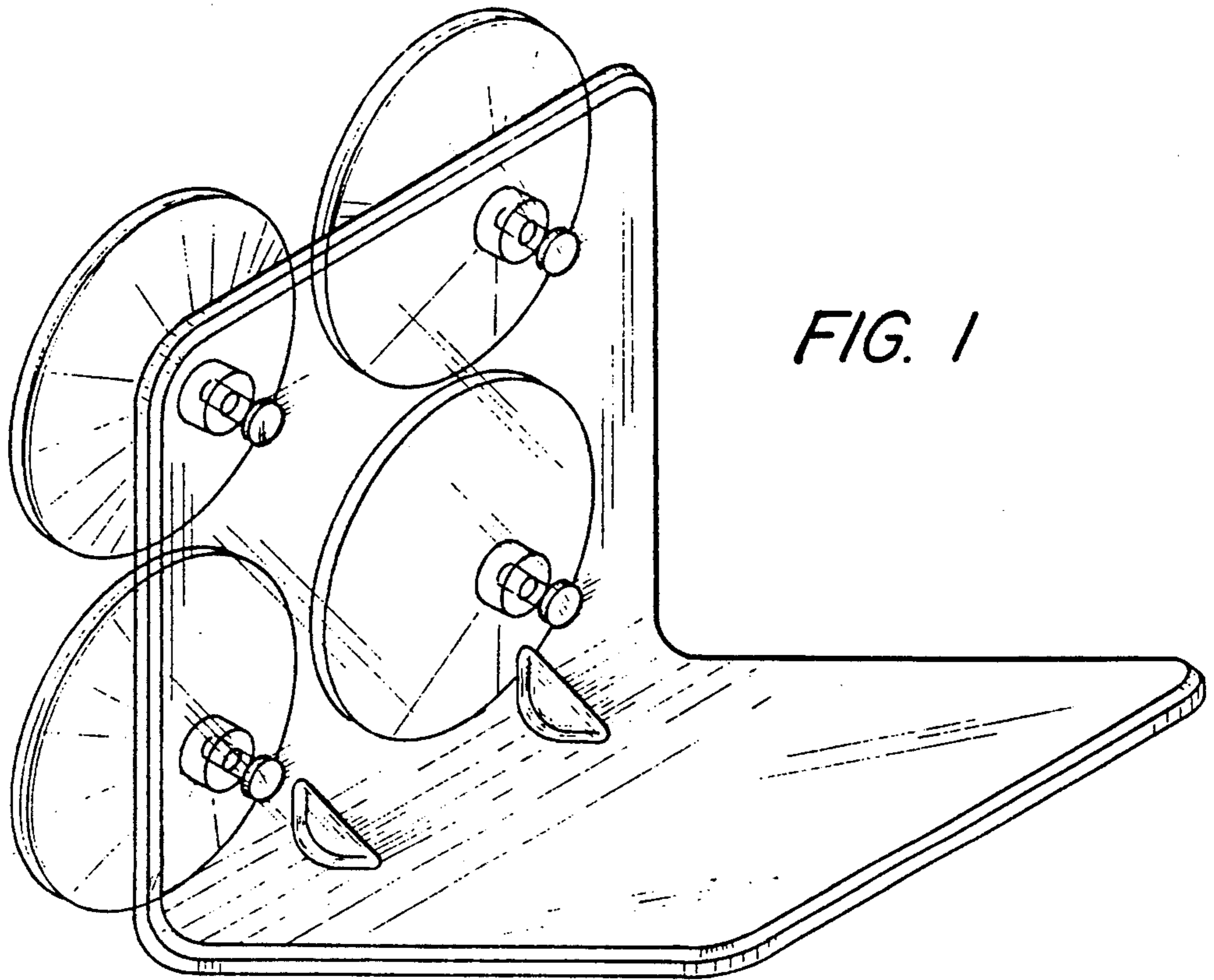

FIG. 1

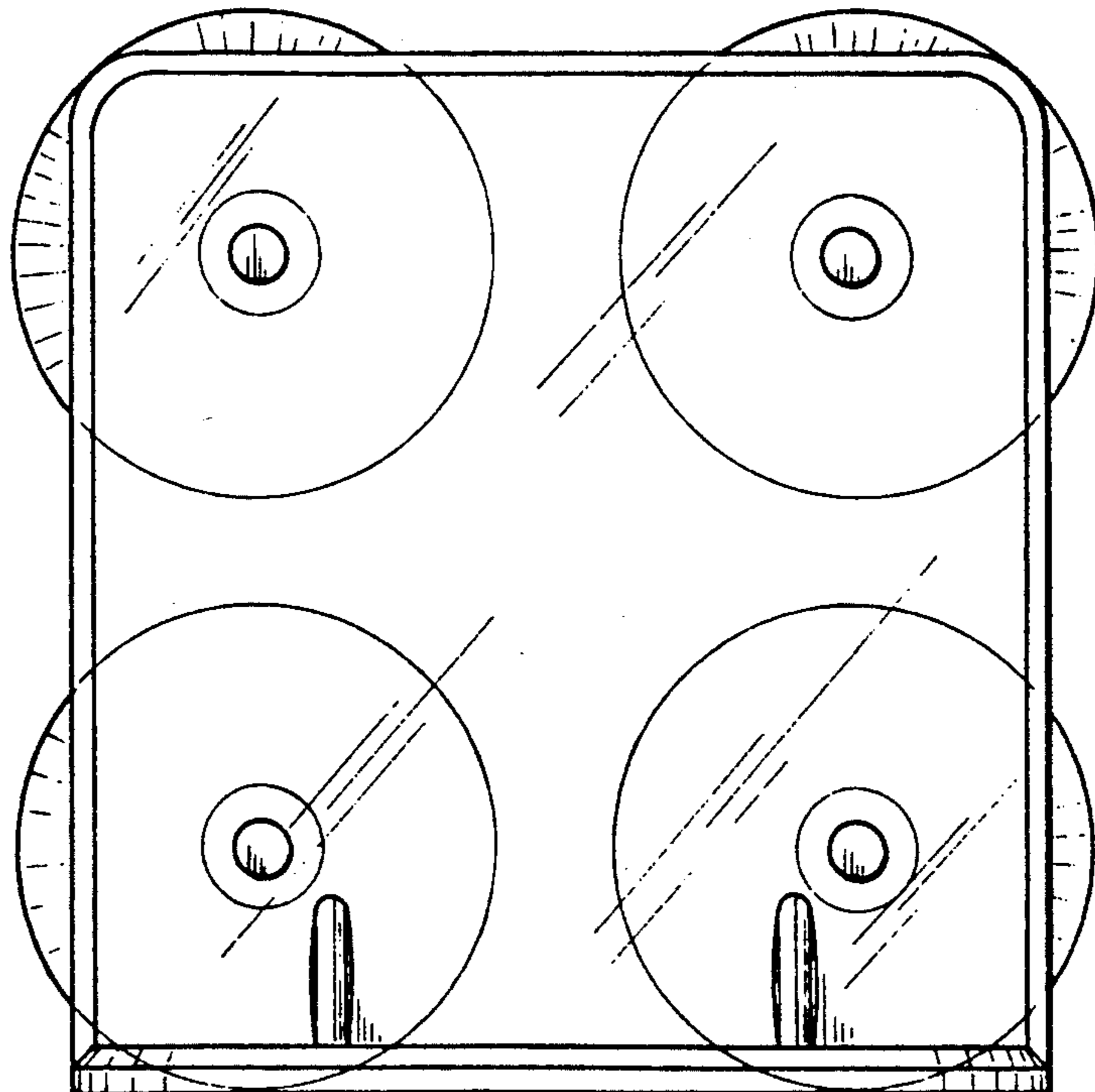

FIG. 2

FIG. 3

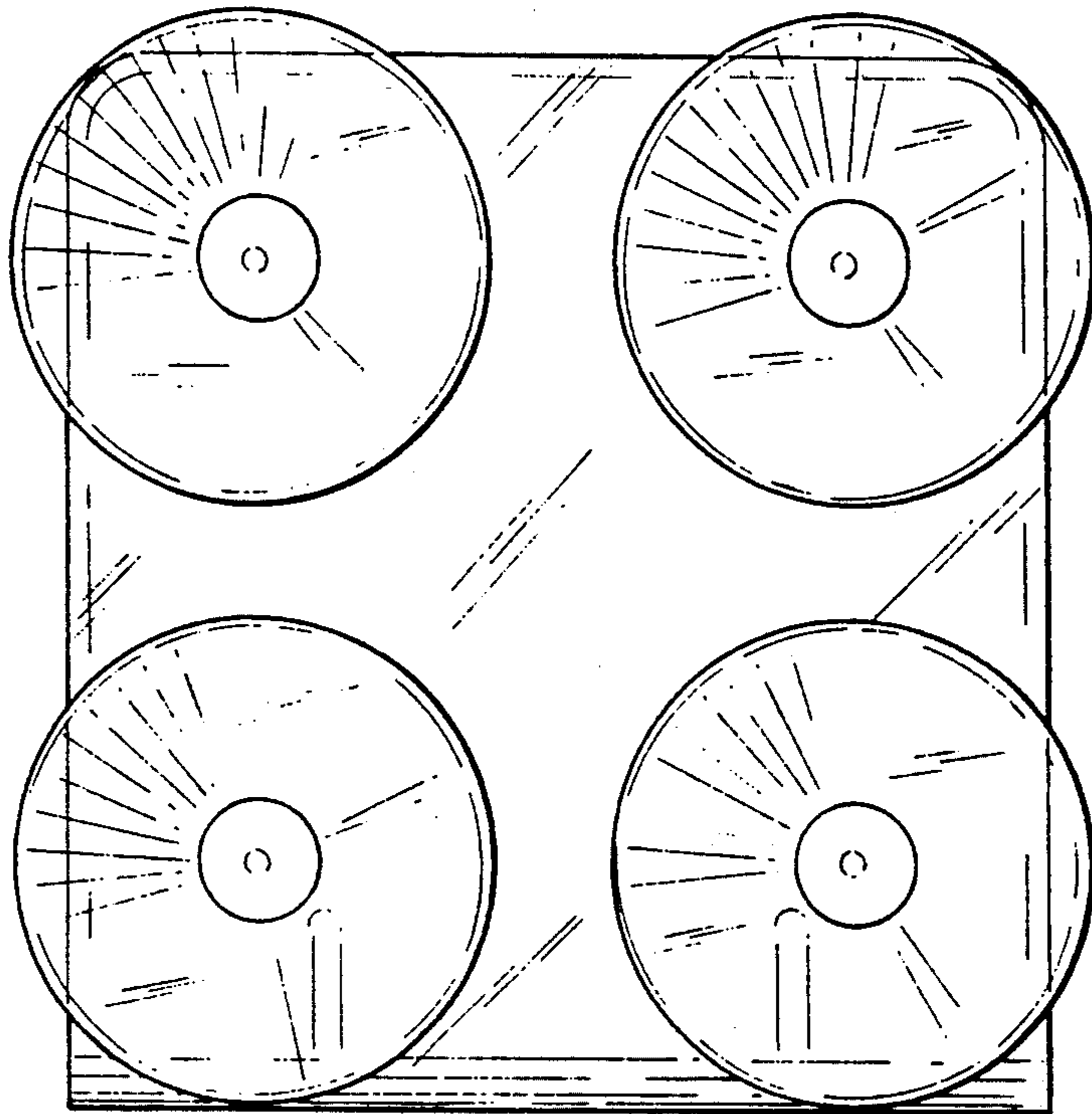
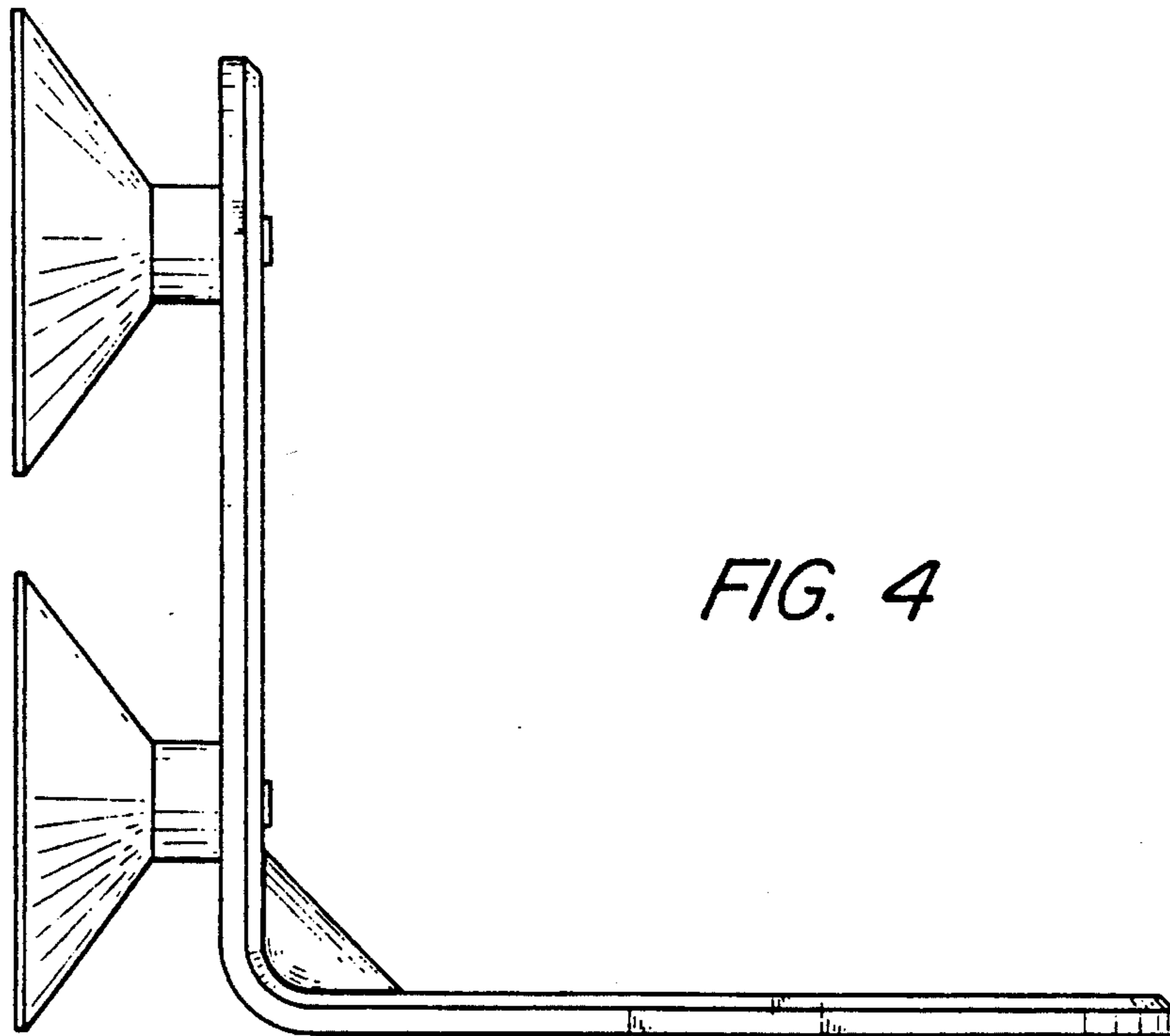

FIG. 4



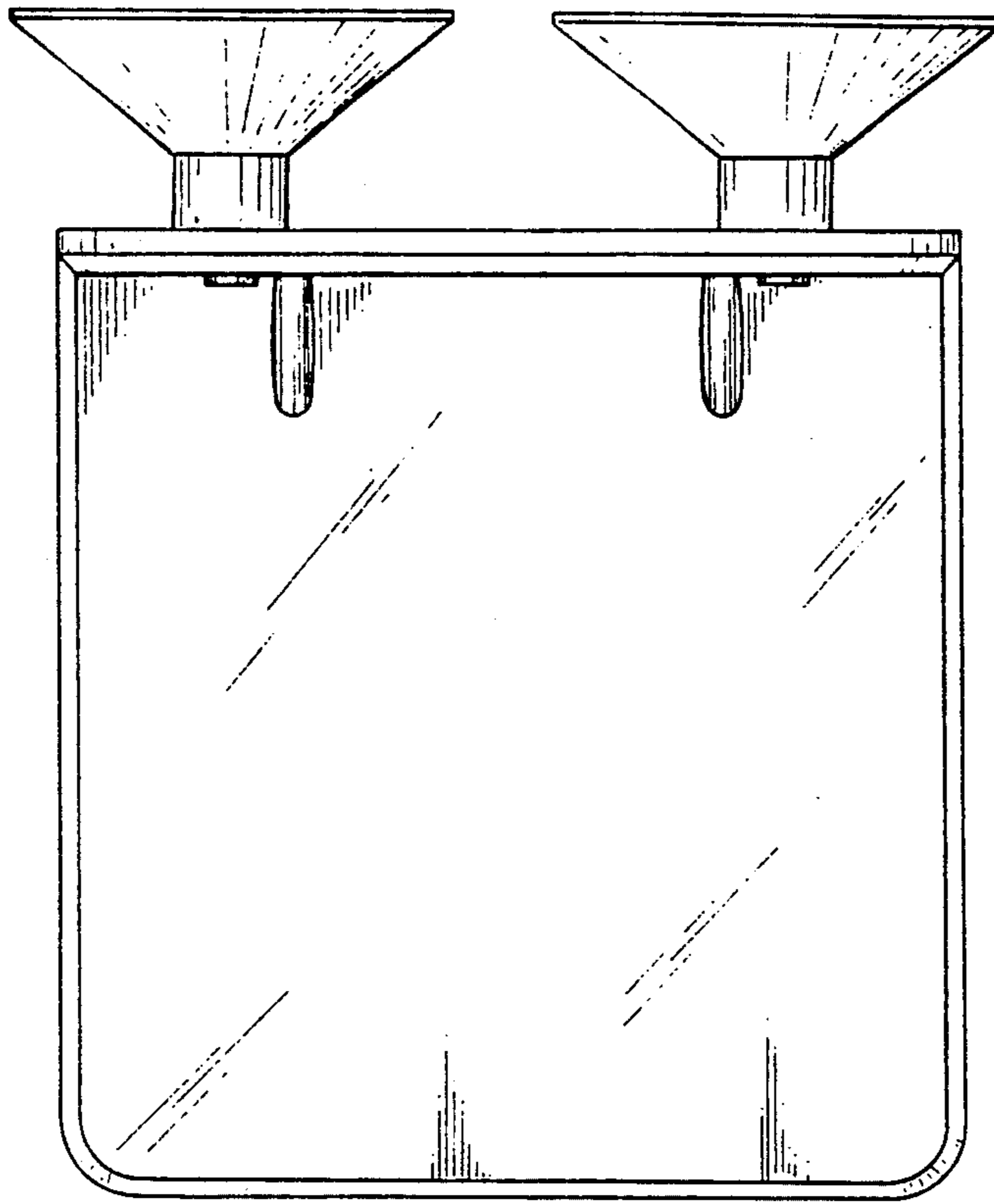

FIG. 5

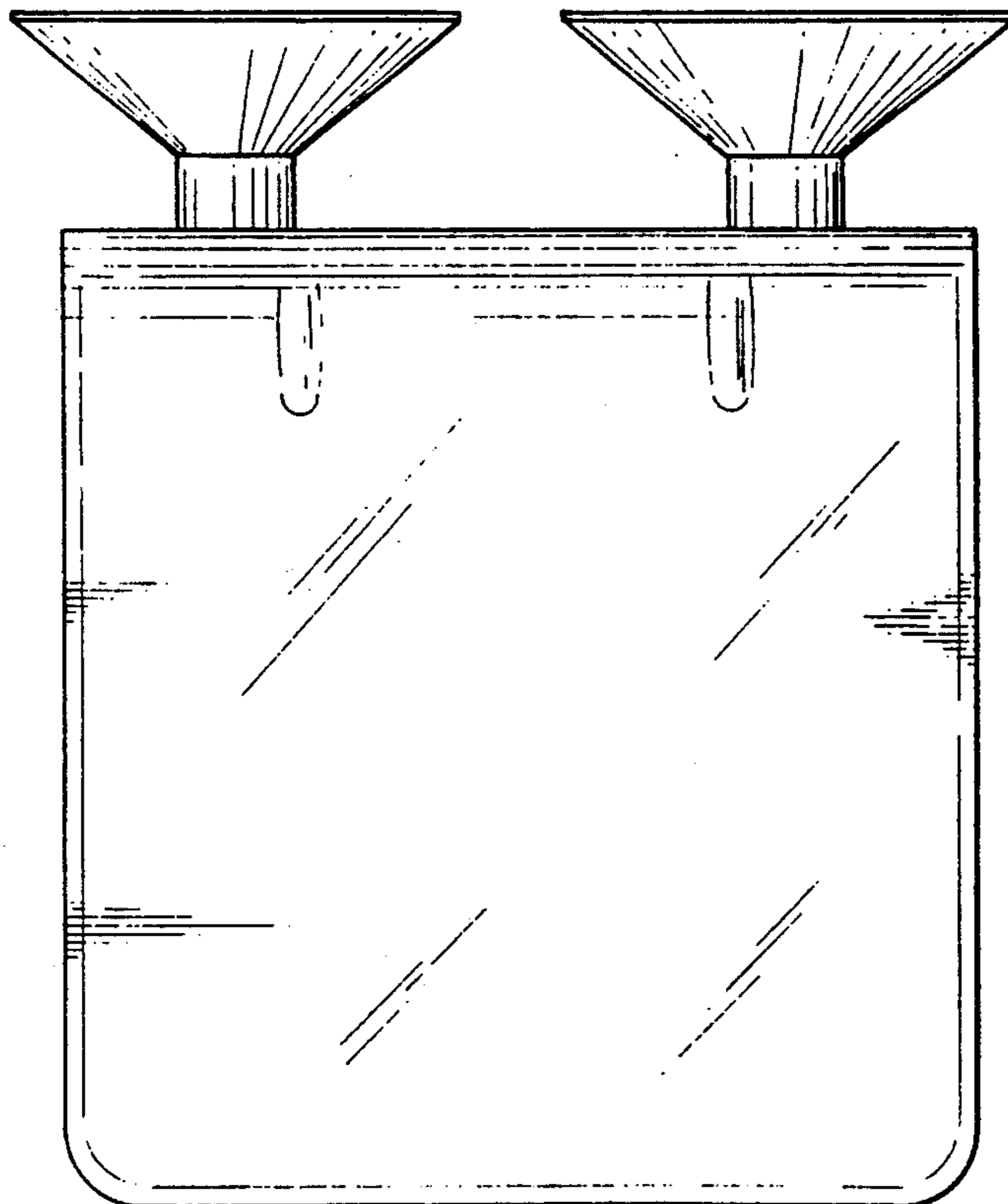

FIG. 6

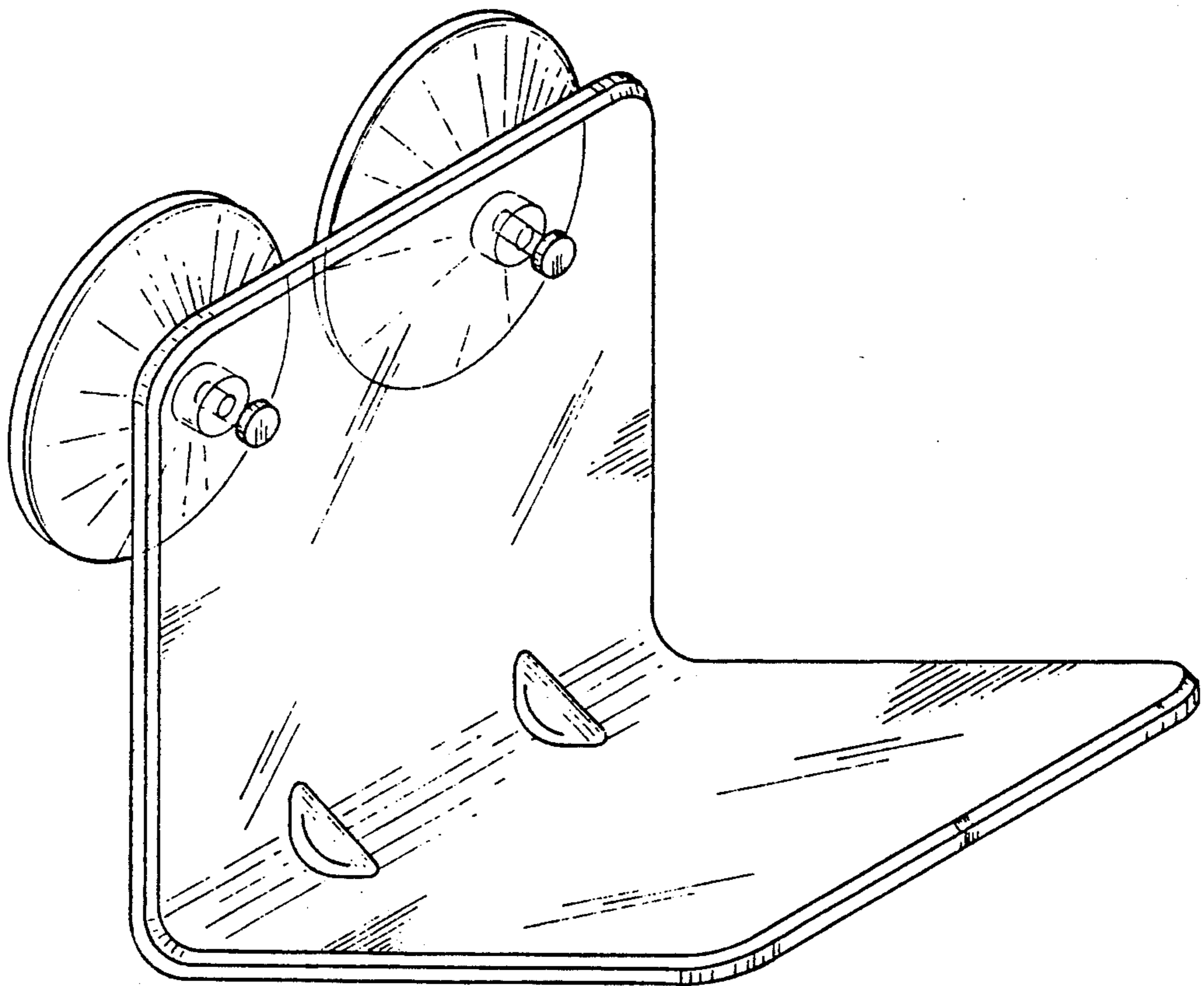

FIG. 7