



US00D333469S

United States Patent [19]

Tezuka

[11] Patent Number: **Des. 333,469**

[45] Date of Patent: **** Feb. 23, 1993**

[54] **ANTENNA FOR AUTOMOBILES**
 [75] Inventor: **Kiyoshi Tezuka, Tokyo, Japan**
 [73] Assignee: **Harada Industry Co., Ltd., Tokyo, Japan**
 [**] Term: **14 Years**
 [21] Appl. No.: **564,305**
 [22] Filed: **Aug. 8, 1990**

[30] **Foreign Application Priority Data**
 Feb. 9, 1990 [JP] Japan 2-3648
 [52] U.S. Cl. **D14/230; D14/234**
 [58] Field of Search **D14/230-238, D14/124, 217, 219; 343/715, 711-713, 872, 900, 906, 741, 748, 882, 720, 808, 805, 878, 795, 912, 873, 745, 749, 901, 903**

[56] **References Cited**
U.S. PATENT DOCUMENTS
 D. 130,434 11/1941 Martin D14/234

D. 325,914 5/1992 Tezuka D14/230
 2,850,305 9/1958 Chadowski et al. 343/711 X
 4,649,398 3/1987 Yamamoto et al. 343/903
 4,721,965 1/1988 Elliott 343/903 X
 4,847,629 7/1989 Shimazaki 343/715 X

Primary Examiner—Theodore M. Shooman
Attorney, Agent, or Firm—Bacon & Thomas

[57] CLAIM

The ornamental design for an antenna for automobiles, as shown.

DESCRIPTION

FIG. 1 is a front and right side perspective view of an antenna for automobiles showing my new design; FIG. 2 is a front elevational view thereof; FIG. 3 is a right side elevational view thereof; FIG. 4 is a top plan view thereof; FIG. 5 is a bottom plan view thereof; FIG. 6 is a left side elevational view thereof; FIG. 7 is a rear elevational view thereof; and, FIG. 8 is a reduced front elevational view thereof, with the antenna rod extended.

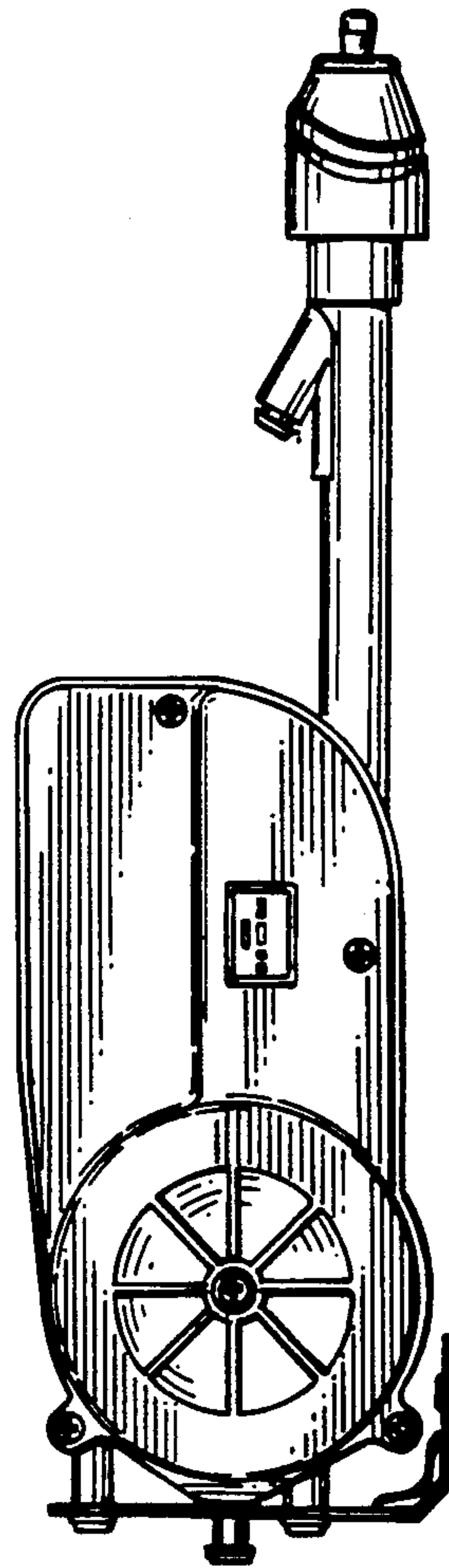
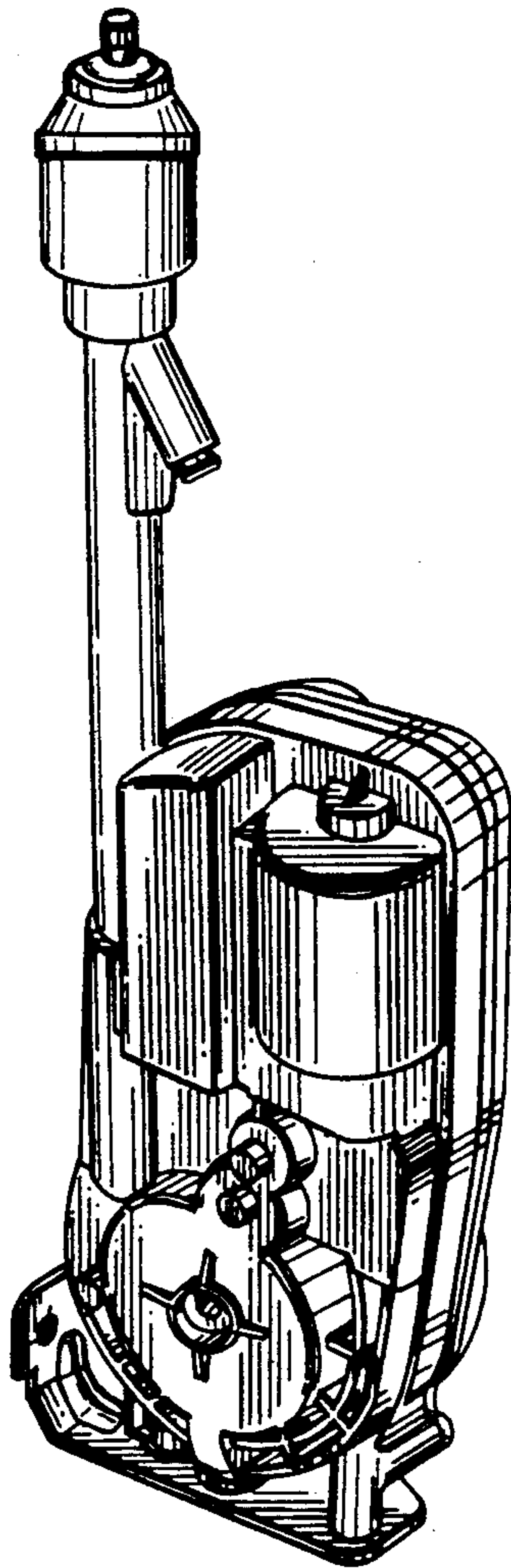

FIG. 1

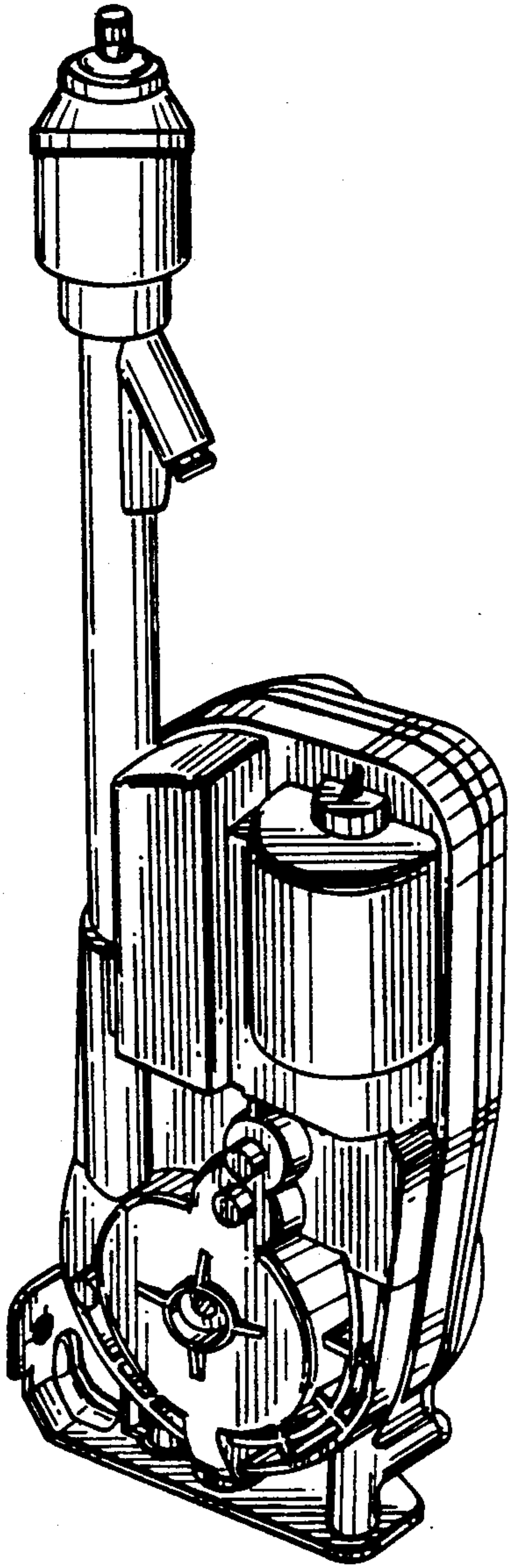

FIG. 2

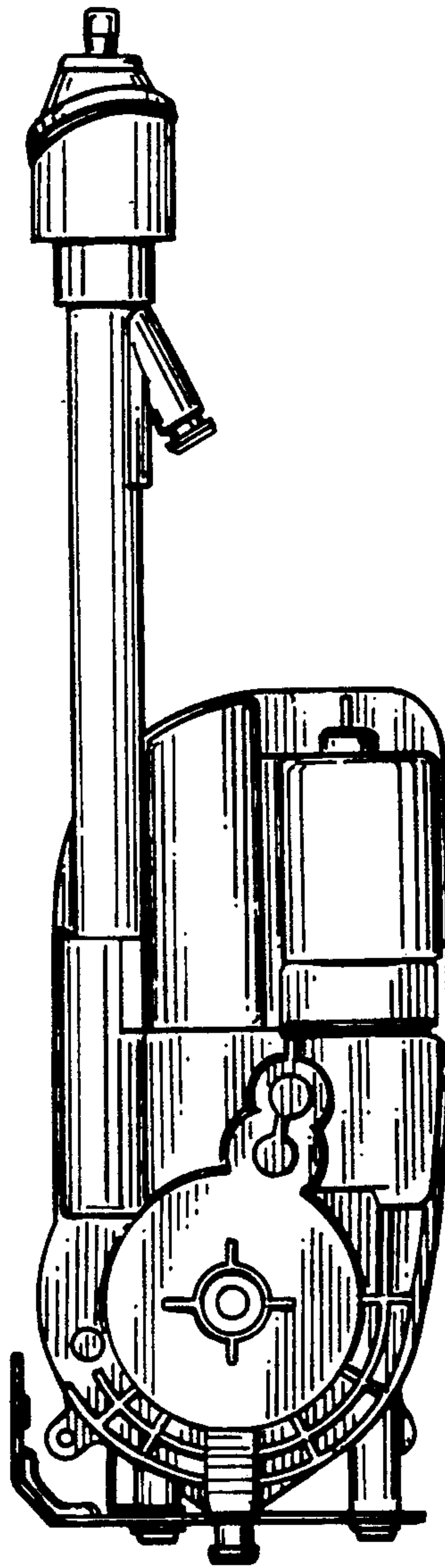

FIG. 3

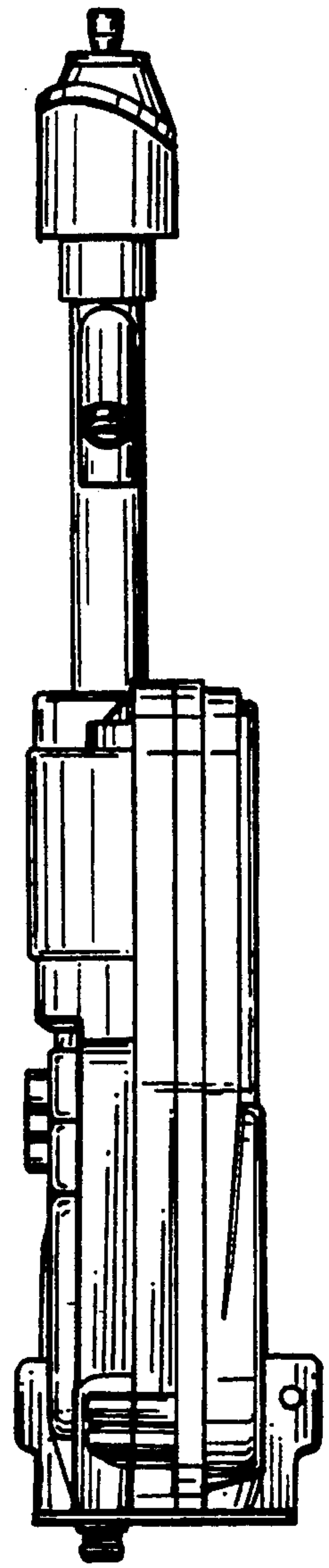

FIG. 4

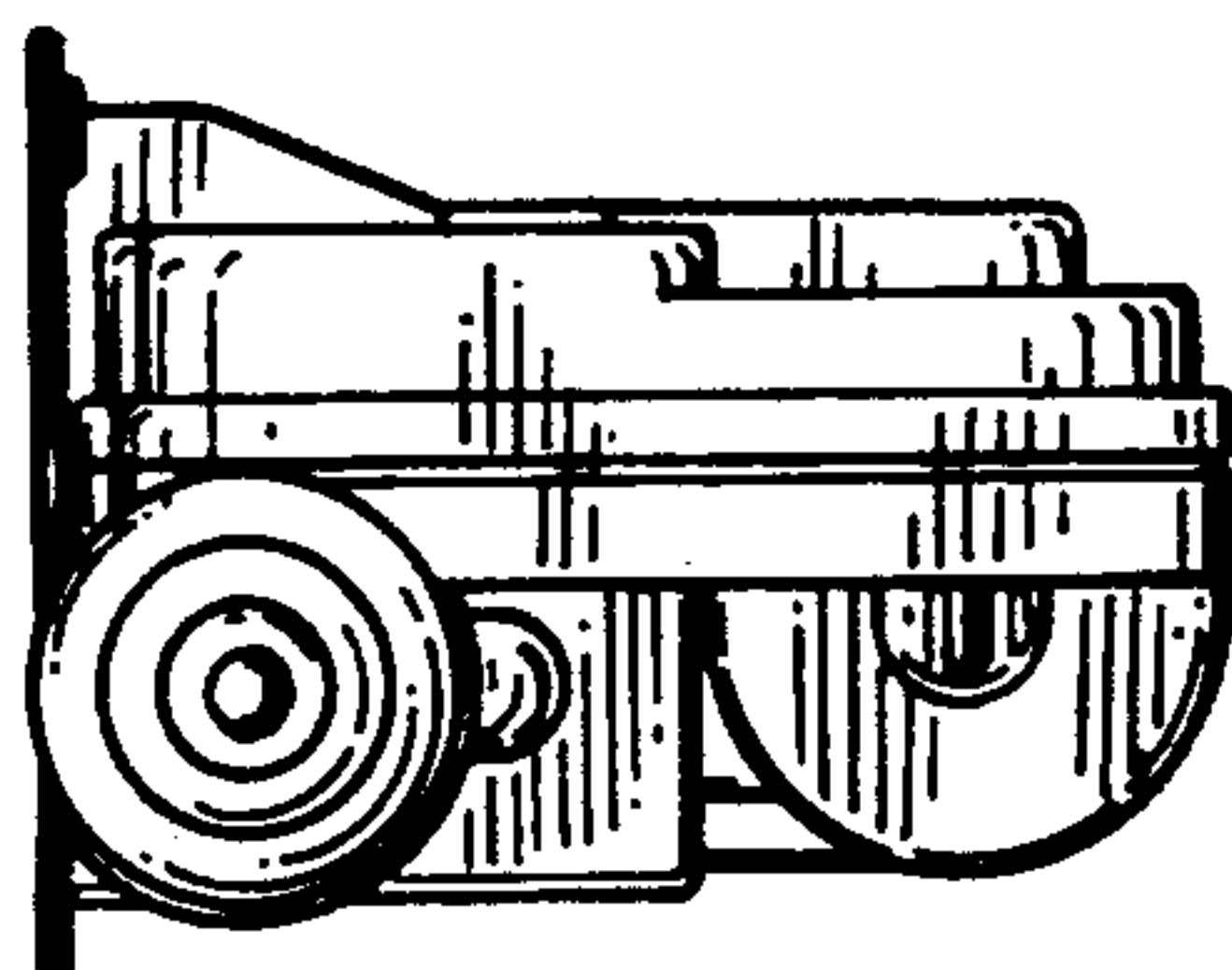

FIG. 5

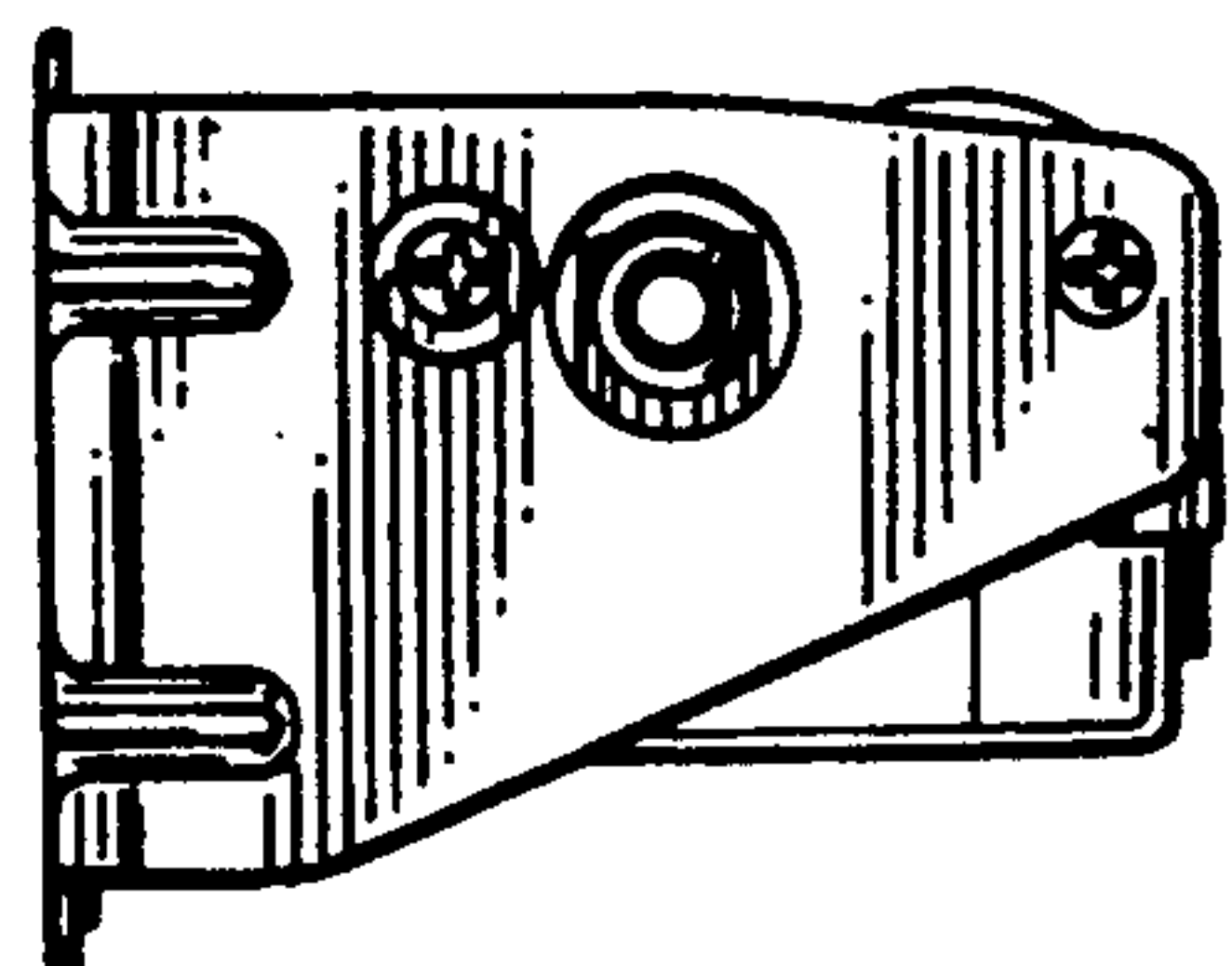

FIG. 6

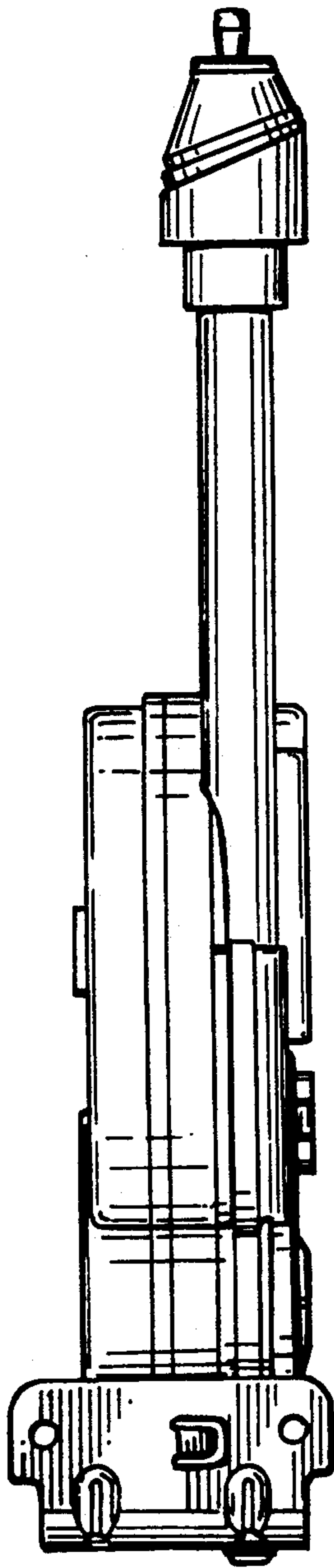

FIG. 7

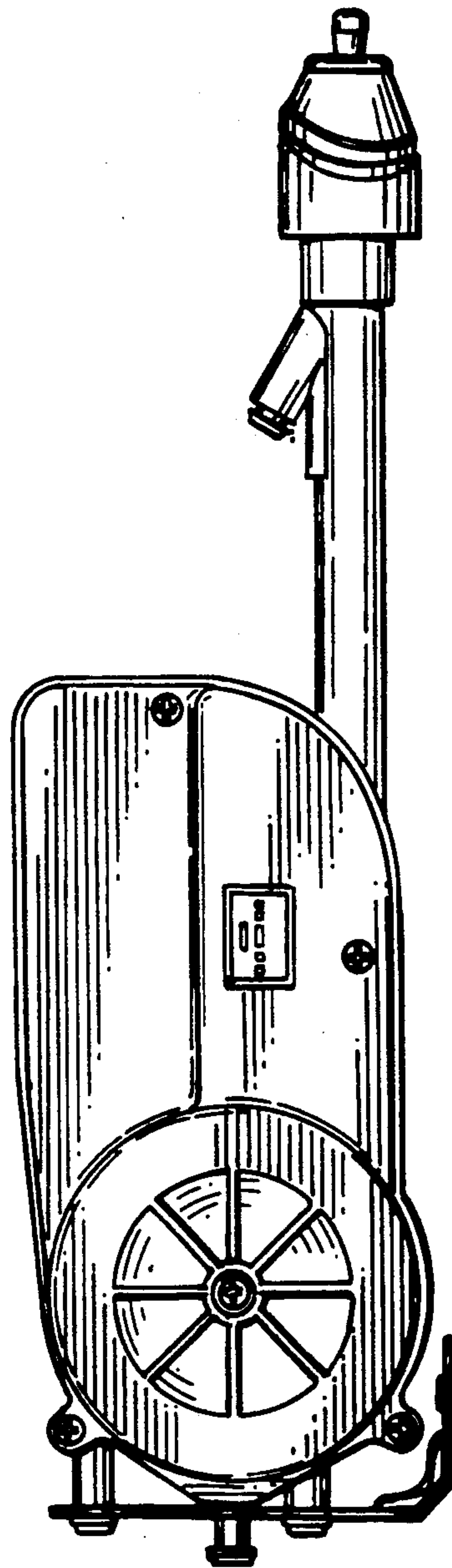

FIG. 8

