



US00D333419S

United States Patent [19]

[11] Patent Number: **Des. 333,419**

McLeod

[45] Date of Patent: **** Feb. 23, 1993**

[54] **BAR LOCK FOR PROTECTION OF A TRUCK CAB WINDOW**

4,653,226	3/1987	Woodrow	49/57 X
4,819,461	4/1989	Pearson	70/14
5,109,683	5/1992	Cartwright	70/14

[76] Inventor: **Andrew McLeod, 6463 Lensen St., Philadelphia, Pa. 19119**

Primary Examiner—Brian N. Vinson
Attorney, Agent, or Firm—Terry M. Gernstein

[**] Term: **14 Years**

[57] **CLAIM**

[21] Appl. No.: **564,553**

The ornamental design for a bar lock for protection of a truck cab window, as shown and described.

[22] Filed: **Aug. 9, 1990**

DESCRIPTION

[52] U.S. Cl. **D8/341; D8/331; D8/346**

[58] Field of Search **D8/330-331, D8/341; 280/727, 748, 770; 49/57; 70/14, 89**

FIG. 1 is a top, front, and left side perspective view of a bar lock for protection of a truck cab window showing my new design;

[56] **References Cited**

U.S. PATENT DOCUMENTS

2,803,471	8/1957	Roth .	
3,032,351	5/1962	Lewis .	
3,204,981	9/1965	Edwards .	
4,283,881	8/1981	Moore et al.	49/57 X

FIG. 2 is an exploded top, front, and left side perspective view thereof;

FIG. 3 is a front elevational view thereof;

FIG. 4 is a rear elevational view thereof;

FIG. 5 is a right side elevational view thereof; and,

FIG. 6 is a top plan view thereof, the bottom being a mirror image of that shown.

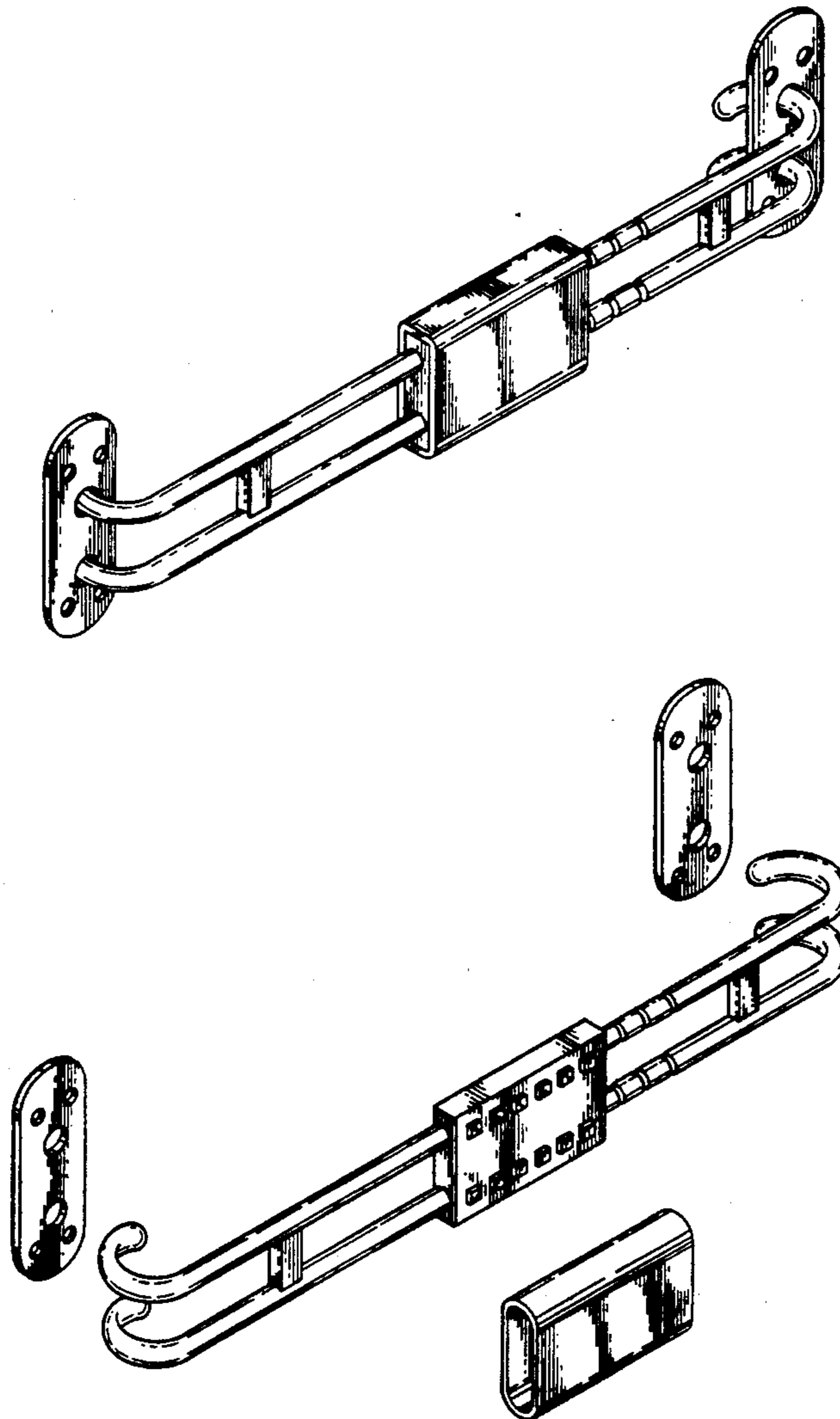

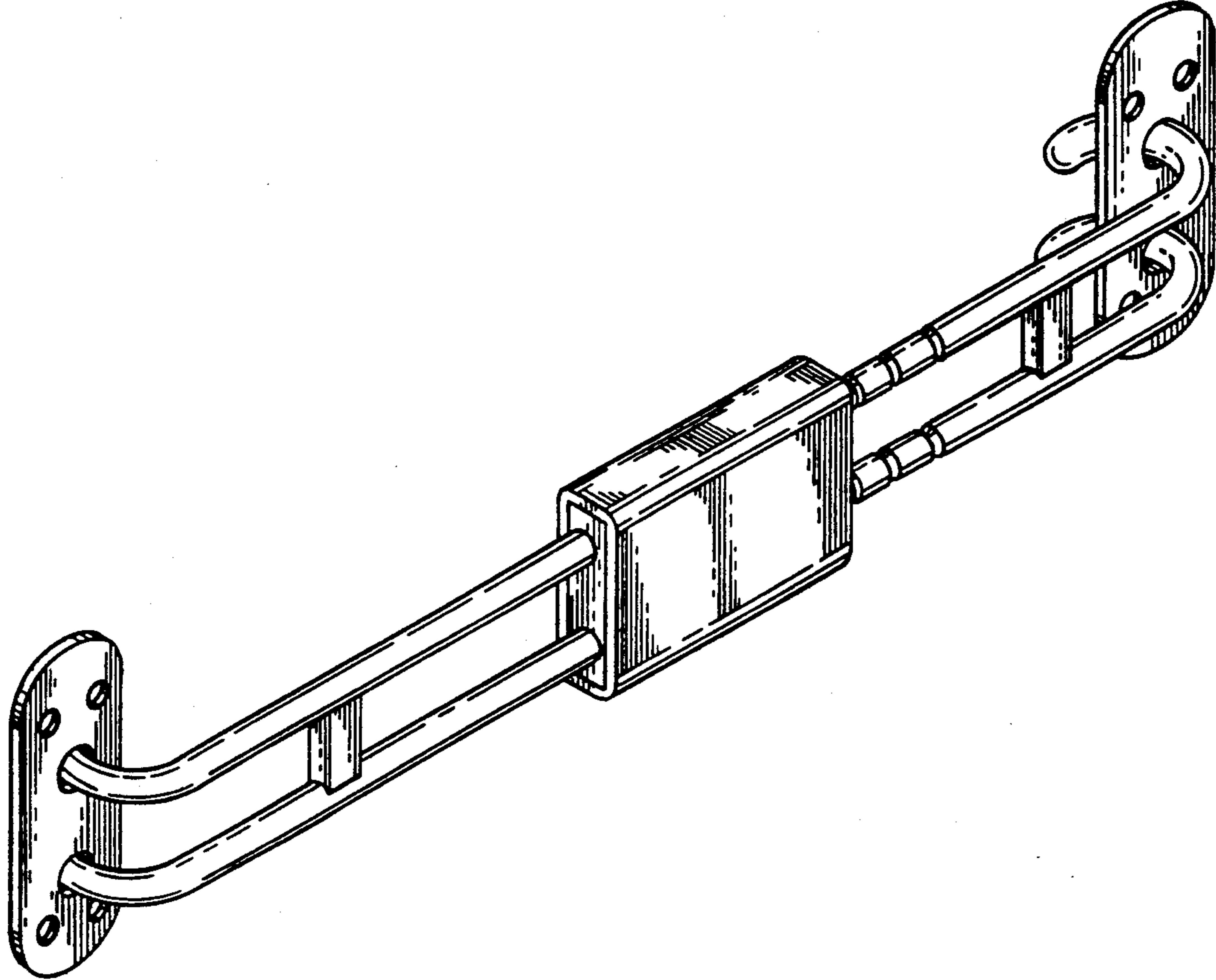

FIG. 1

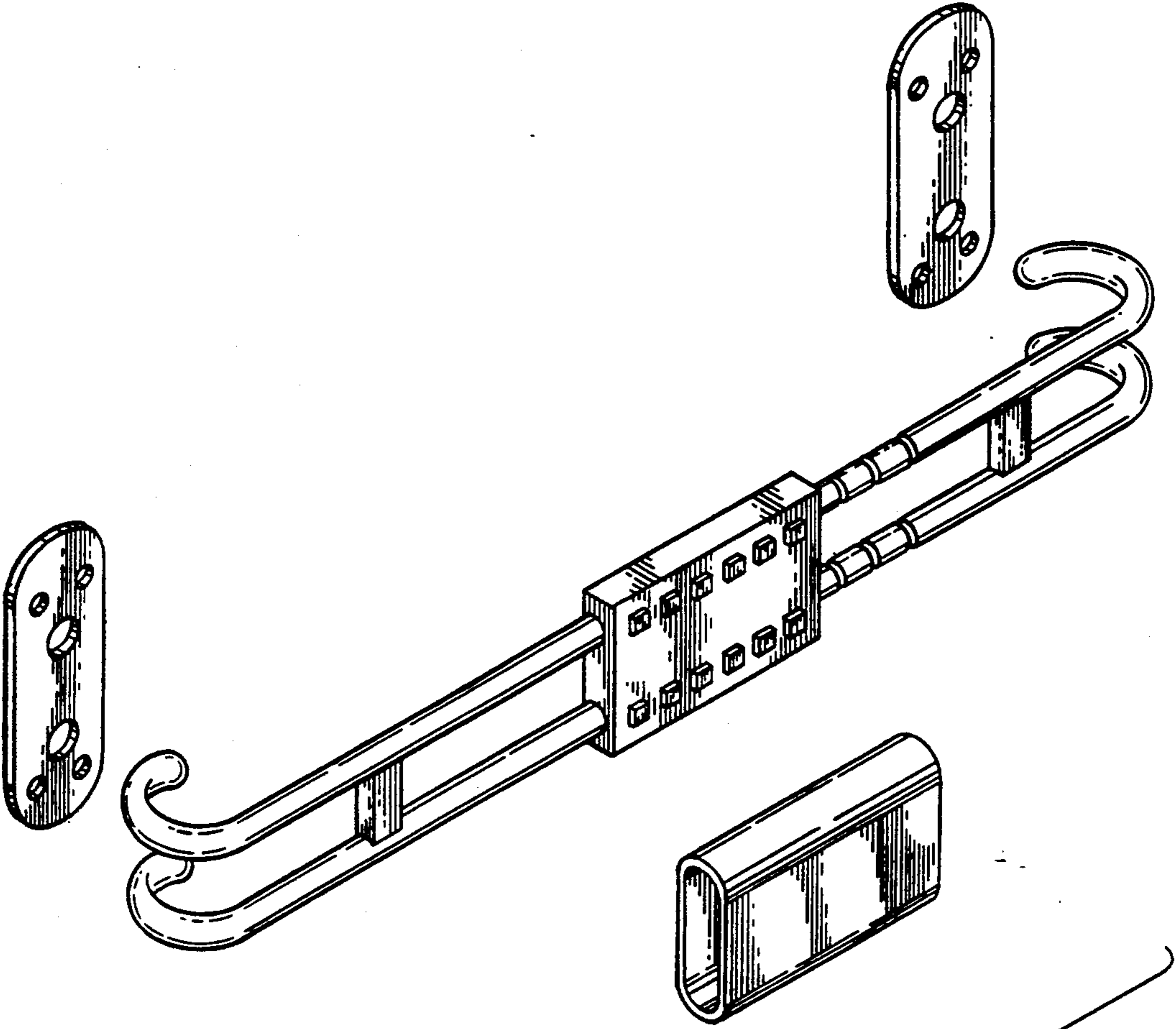

FIG. 2

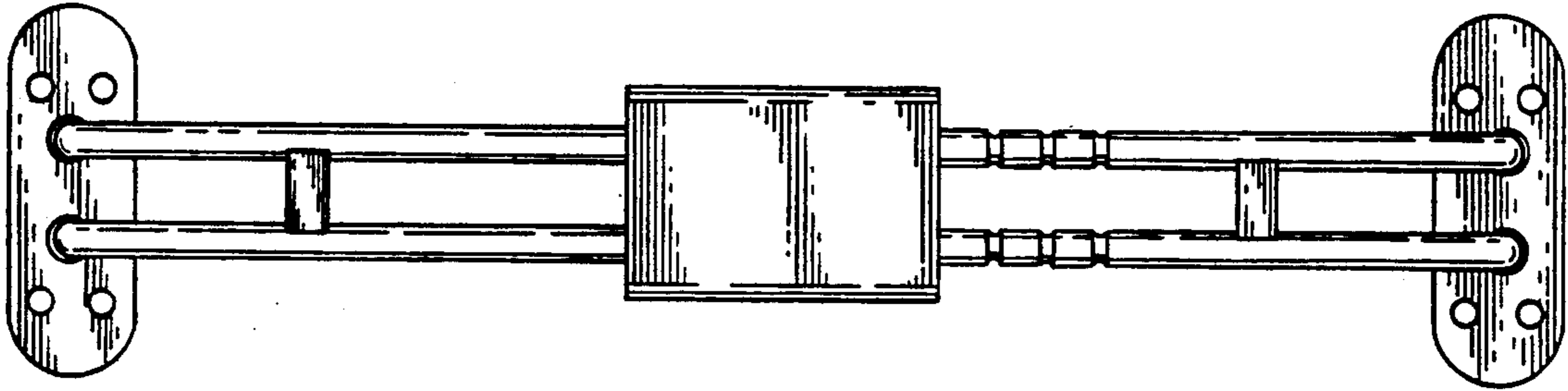

FIG. 3

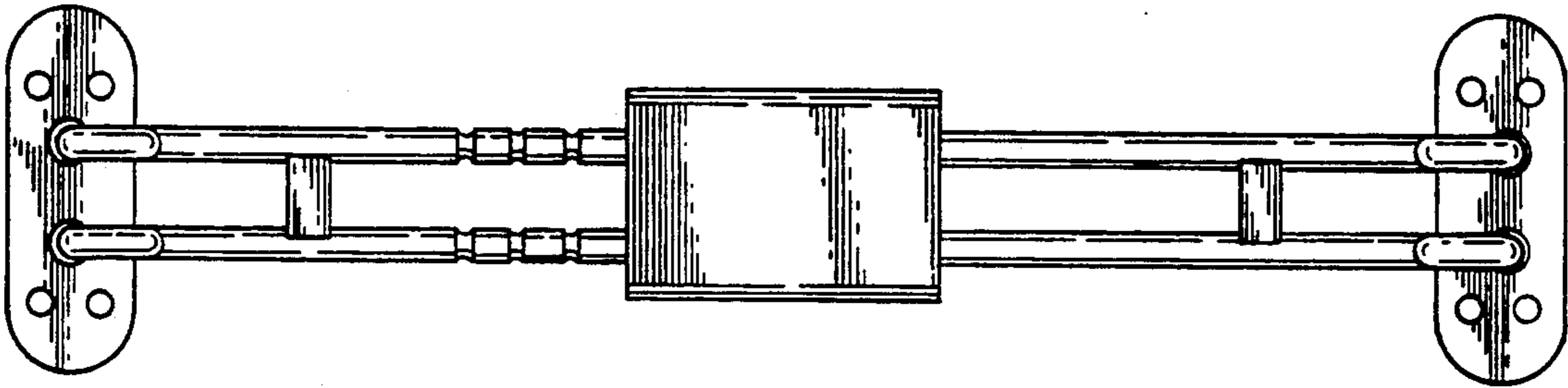

FIG. 4

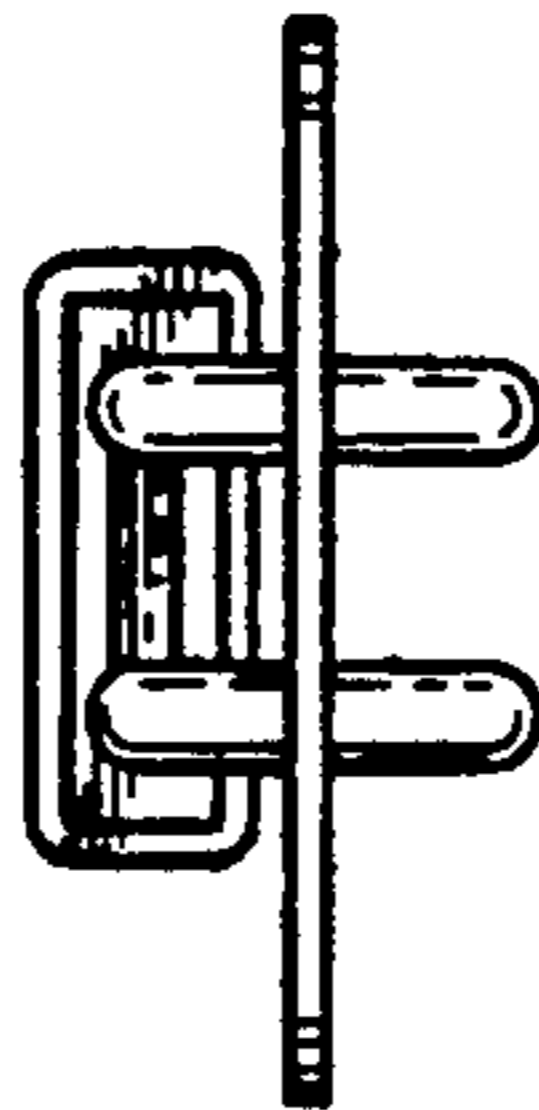

FIG. 5

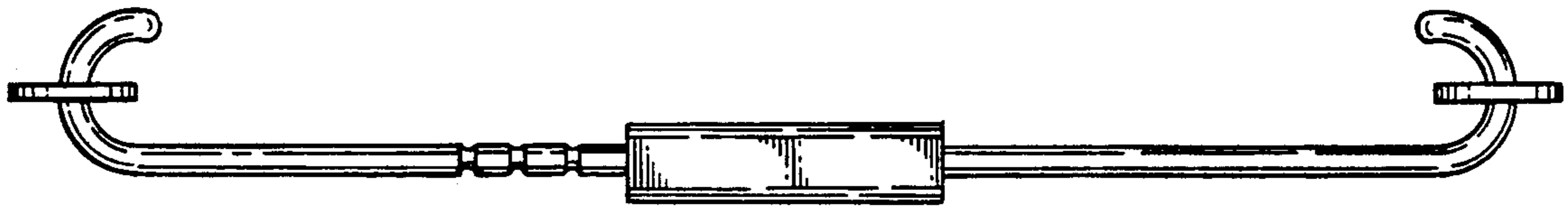

FIG. 6