



US00D333250S

United States Patent [19]

[11] Patent Number: Des. 333,250

Ciccone, III et al.

[45] Date of Patent: ** Feb. 16, 1993

[54] HANDGRIP FOR A HACKSAW ASSEMBLY

2,703,121	3/1955	Jolie	30/511
2,725,085	11/1955	Doherty et al.	30/511
2,782,821	2/1957	Gunnerson	30/510
4,349,059	9/1982	Hepworth	30/513

[75] Inventors: Theodore P. Ciccone, III, West Hartford; Joseph P. DeCarolus, Bristol, both of Conn.

OTHER PUBLICATIONS

[73] Assignee: The Stanley Works, New Britain, Conn.

Stanley Tools Catalog, 1980, 11A14, p. 33, Saws.

[**] Term: 14 Years

Primary Examiner—Bernard Ansher
Assistant Examiner—P. Hyder

[21] Appl. No.: 663,637

[57] CLAIM

[22] Filed: Mar. 4, 1991

The ornamental design for a handgrip for a hacksaw assembly, as shown and described.

[52] U.S. Cl. D8/97

[58] Field of Search D8/95, 97, 107; 30/506, 30/510, 511, 513, 514, 517, 339

DESCRIPTION

[56] References Cited

U.S. PATENT DOCUMENTS

D. 70,665	7/1926	Forsberg	D8/97
D. 176,770	1/1956	Jacoff	30/511
D. 184,860	4/1959	Dreier	D8/97
D. 259,328	5/1981	Covey	D8/97
D. 269,848	7/1983	Covey	D8/97
2,546,660	3/1951	Wilcox	30/511

FIG. 1 is a right side elevational view of a handgrip for a hacksaw assembly showing our new design, the left side being a mirror image thereof; FIG. 2 is a front elevational view thereof; FIG. 3 is a rear elevational view thereof; FIG. 4 is a top plan view thereof; FIG. 5 is a bottom view thereof; and, FIG. 6 is a right side elevational view thereof, the broken line portions of the drawing being for illustrative purposes only and forms no part of the claimed design.

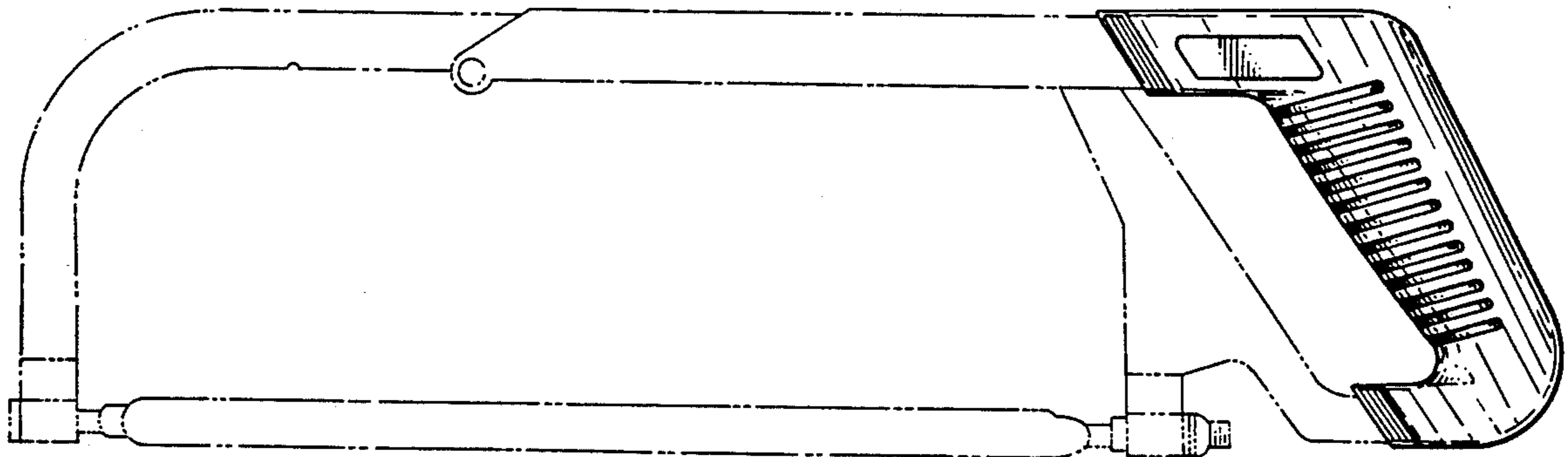

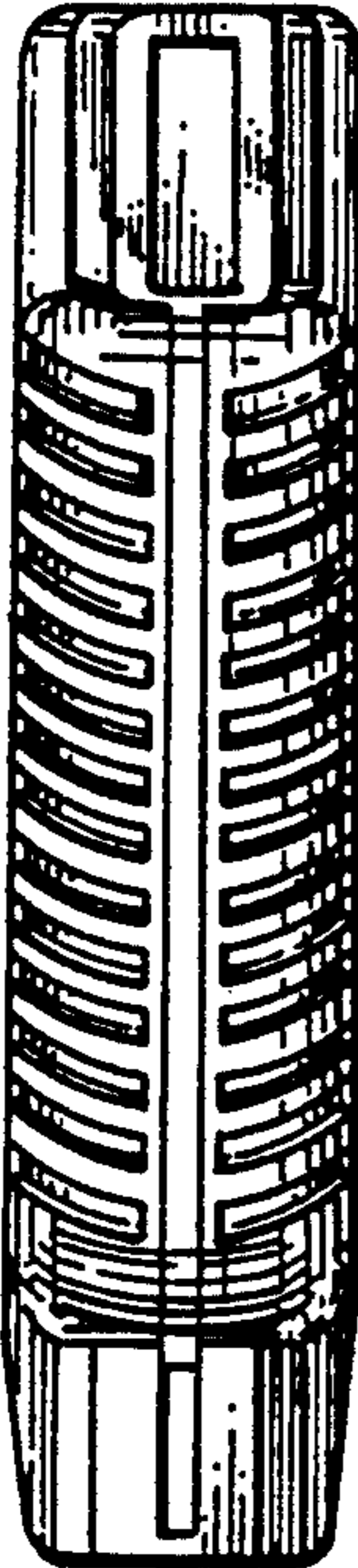

FIG. 2

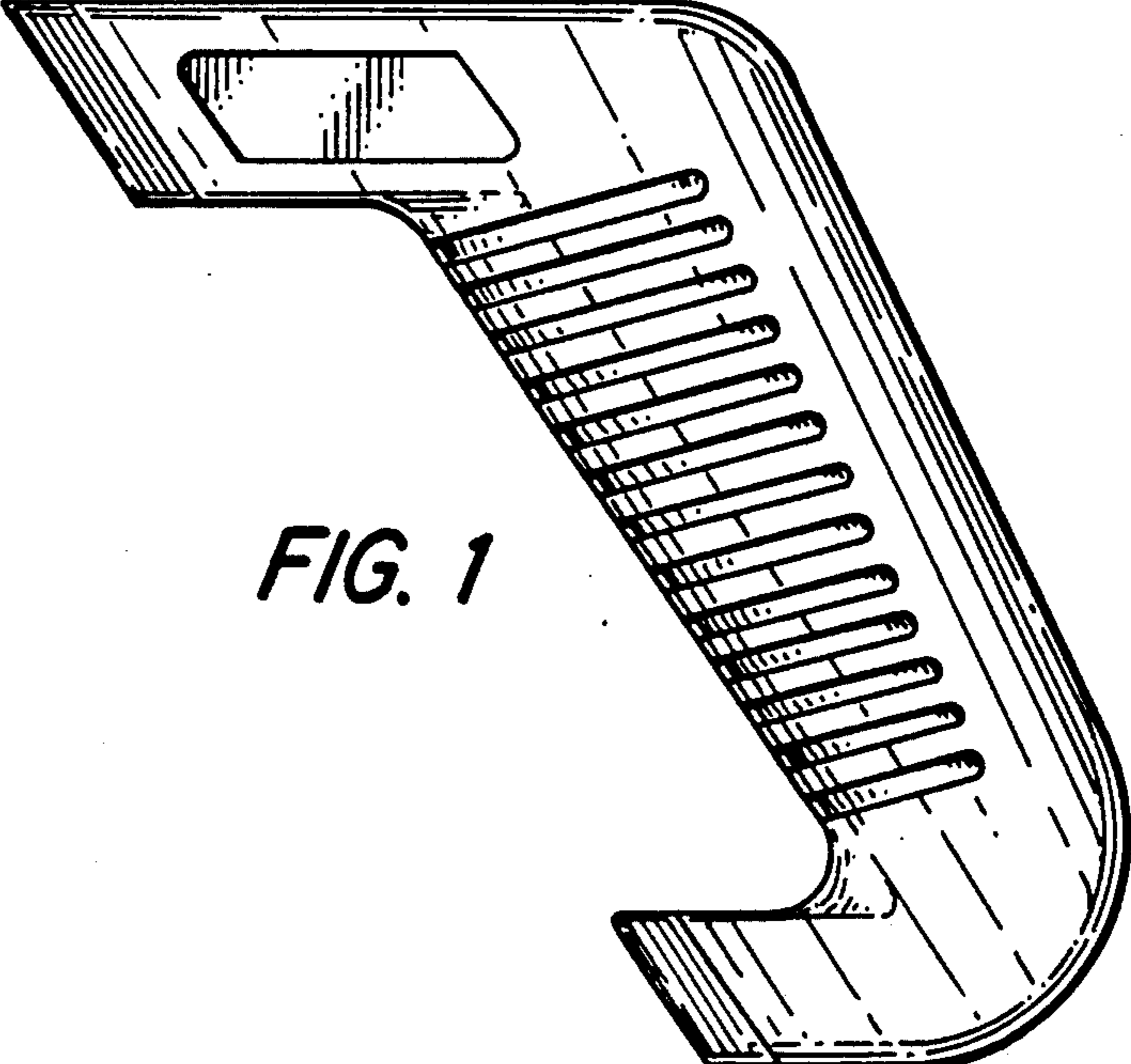

FIG. 1

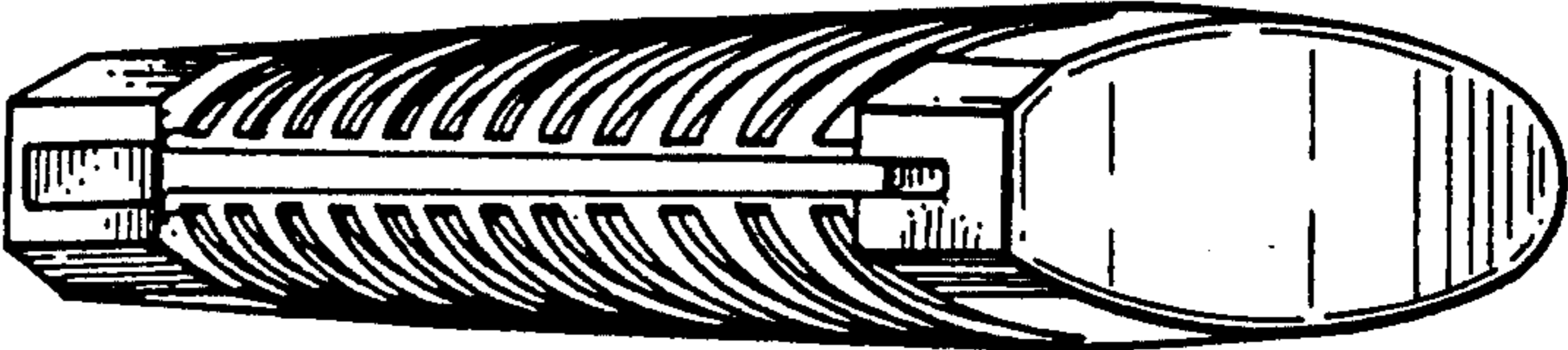

FIG. 5

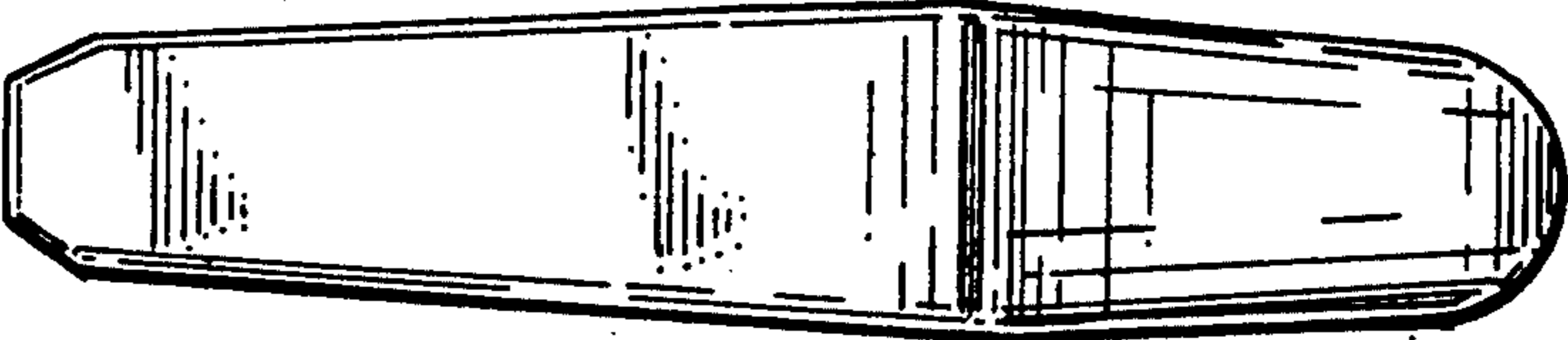

FIG. 4



FIG. 3

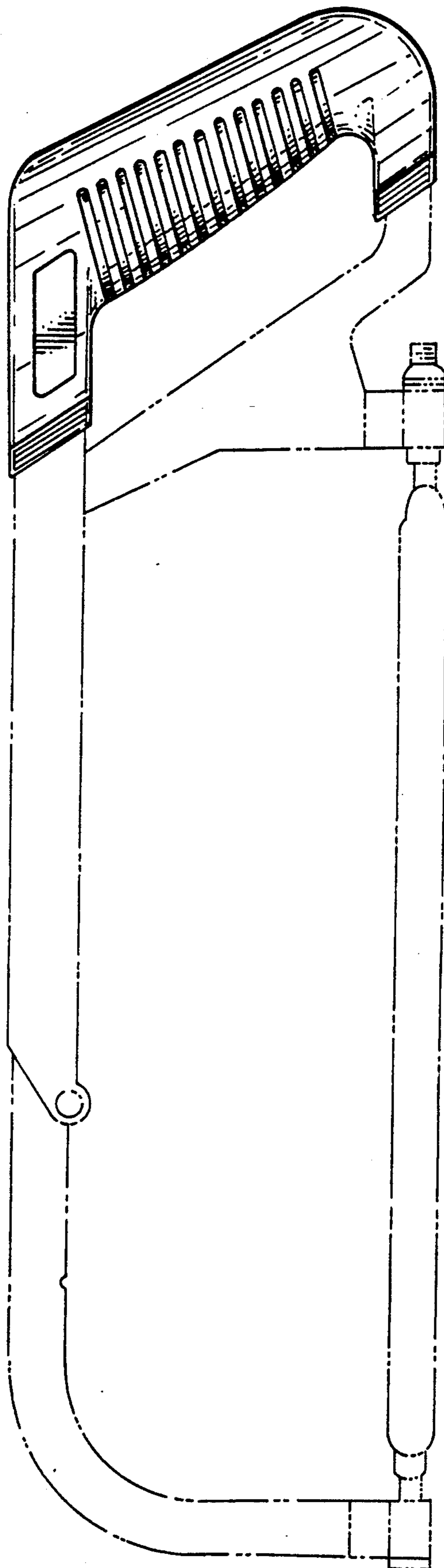

FIG. 6