



US00D332977S

# United States Patent [19]

[11] Patent Number: **Des. 332,977**

Huffman et al.

[45] Date of Patent: **\*\* Feb. 2, 1993**

[54] STUNT RIDING TOY

D. 293,010	12/1987	Fortin	.....	D21/81
4,384,731	5/1983	Webb	.....	280/87.042
4,915,403	4/1990	Wild	.....	280/87.042

[75] Inventors: **Michael L. Huffman; Michael D. Commerford**, both of Festus, Mo.

*Primary Examiner*—Bernard Ansher  
*Assistant Examiner*—R. Barkai  
*Attorney, Agent, or Firm*—Paul M. Denk

[73] Assignee: **High Tech Toys, Inc.**, Festus, Mo.

[\*\*] Term: **14 Years**

[57] **CLAIM**

[21] Appl. No.: **702,711**

The ornamental design for the stunt riding toy, as shown and described.

[22] Filed: **May 20, 1991**

[52] U.S. Cl. .... **D21/71**

[58] Field of Search ..... **D21/71, 76, 80, 81, D21/121, 128, 132, 134, 137, 139, 140, 141, 159; D12/88, 135, 211; D6/300; D34/12; 446/425, 424, 444, 455, 426, 440, 465, 456, 457, 470, 471; 280/80.042, 47.31, 47.26, 87.041, 47.27, 30, 206; 180/180**

**DESCRIPTION**

FIG. 1 is a perspective view of a stunt riding toy showing our new design;  
FIG. 2 is a top plan view thereof;  
FIG. 3 is a left side elevational view thereof, the right side elevational view being a mirror image;  
FIG. 4 is a front elevational view thereof;  
FIG. 5 is bottom plan view thereof; and,  
FIG. 6 is a rear elevational view thereof.  
The broken line showing of the flag and pole in FIGS. 1, 3, 4, and 6 is for illustrative purposes only and forms no part of the claimed design.

[56] **References Cited**

**U.S. PATENT DOCUMENTS**

D. 84,828	8/1931	Gill	.....	D21/71
D. 218,628	9/1970	Gonzales	.....	D21/71
D. 246,198	10/1977	Rose	.....	D21/71

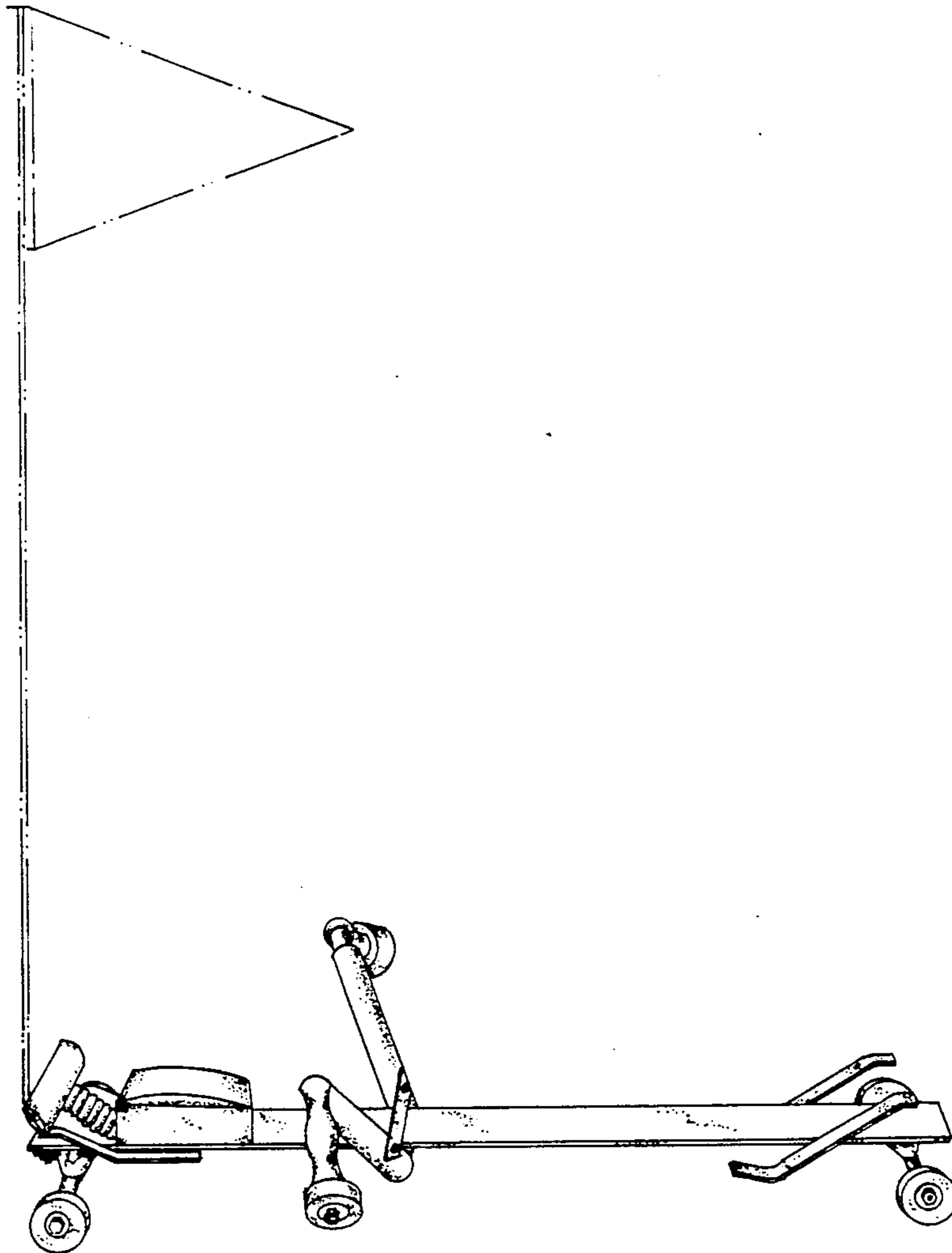

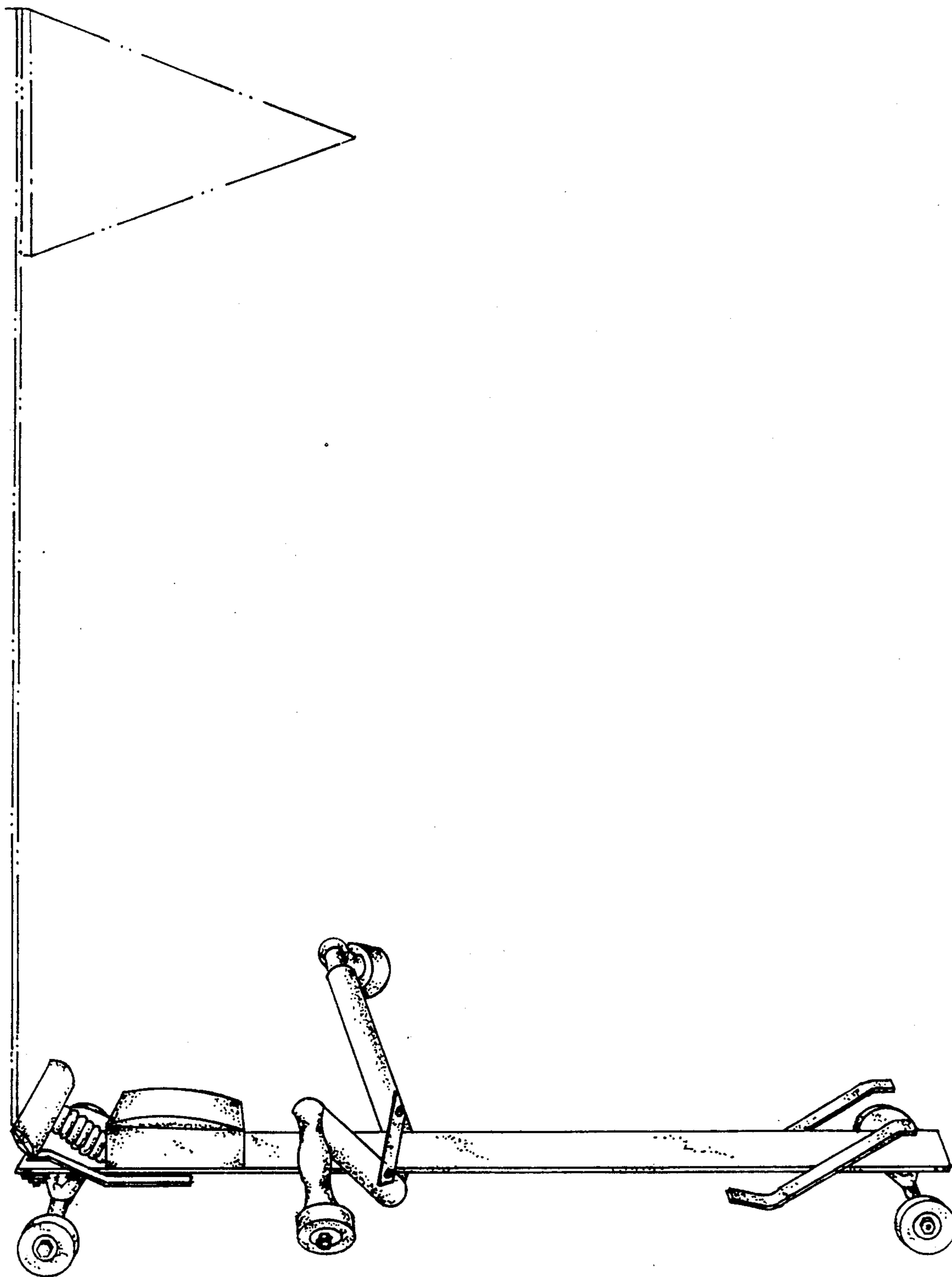

FIG. I.

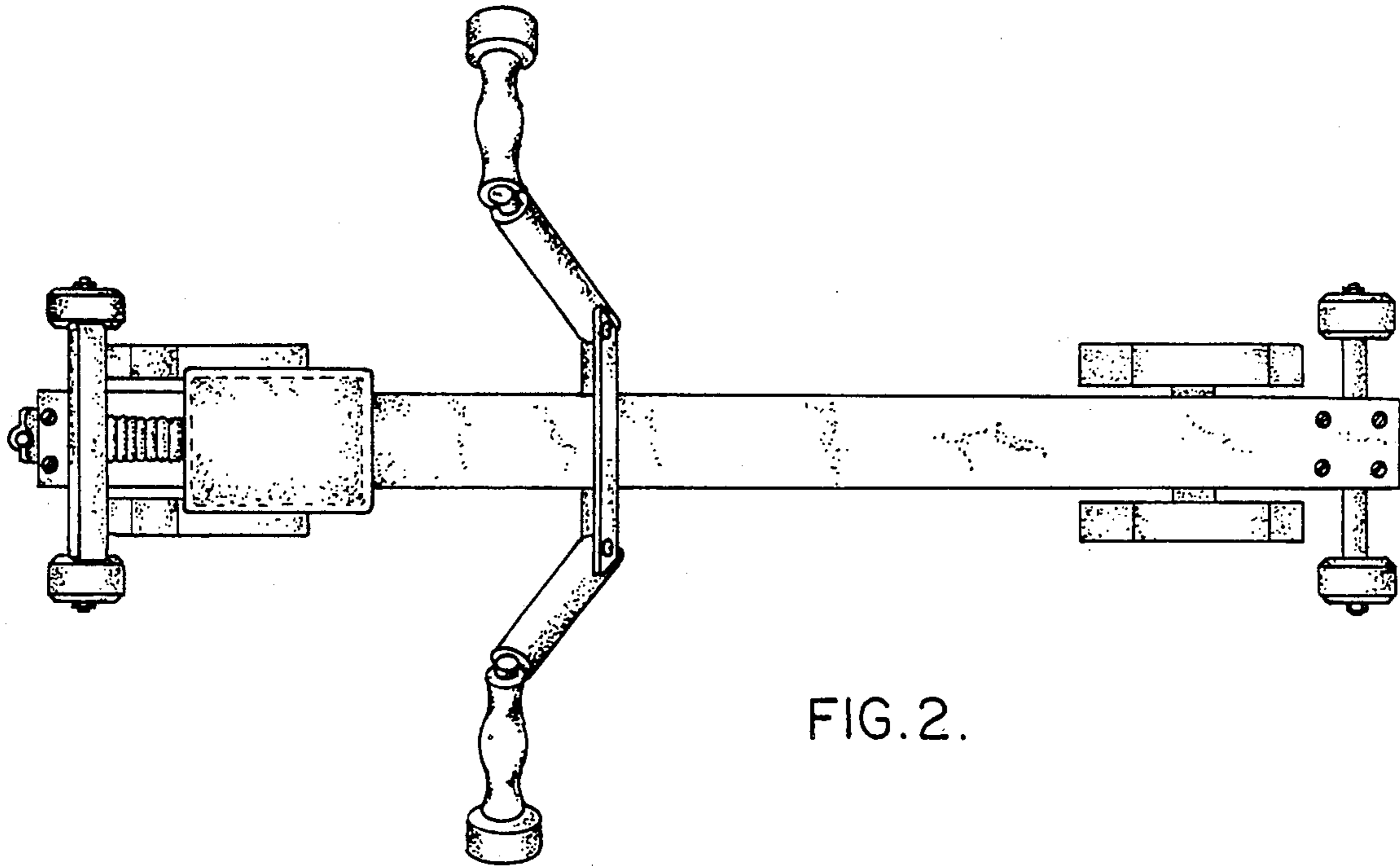

FIG. 2.

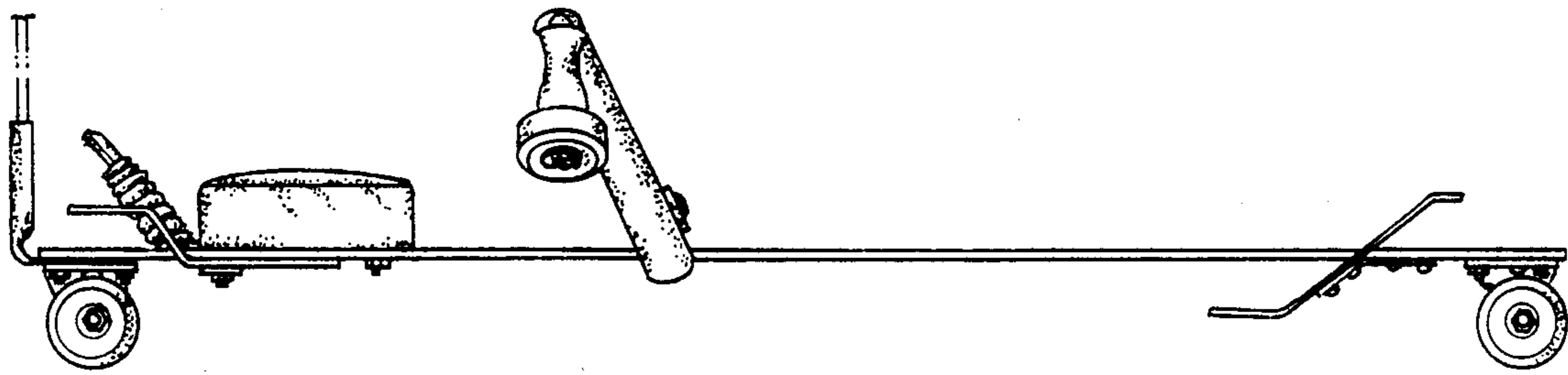

FIG. 3.

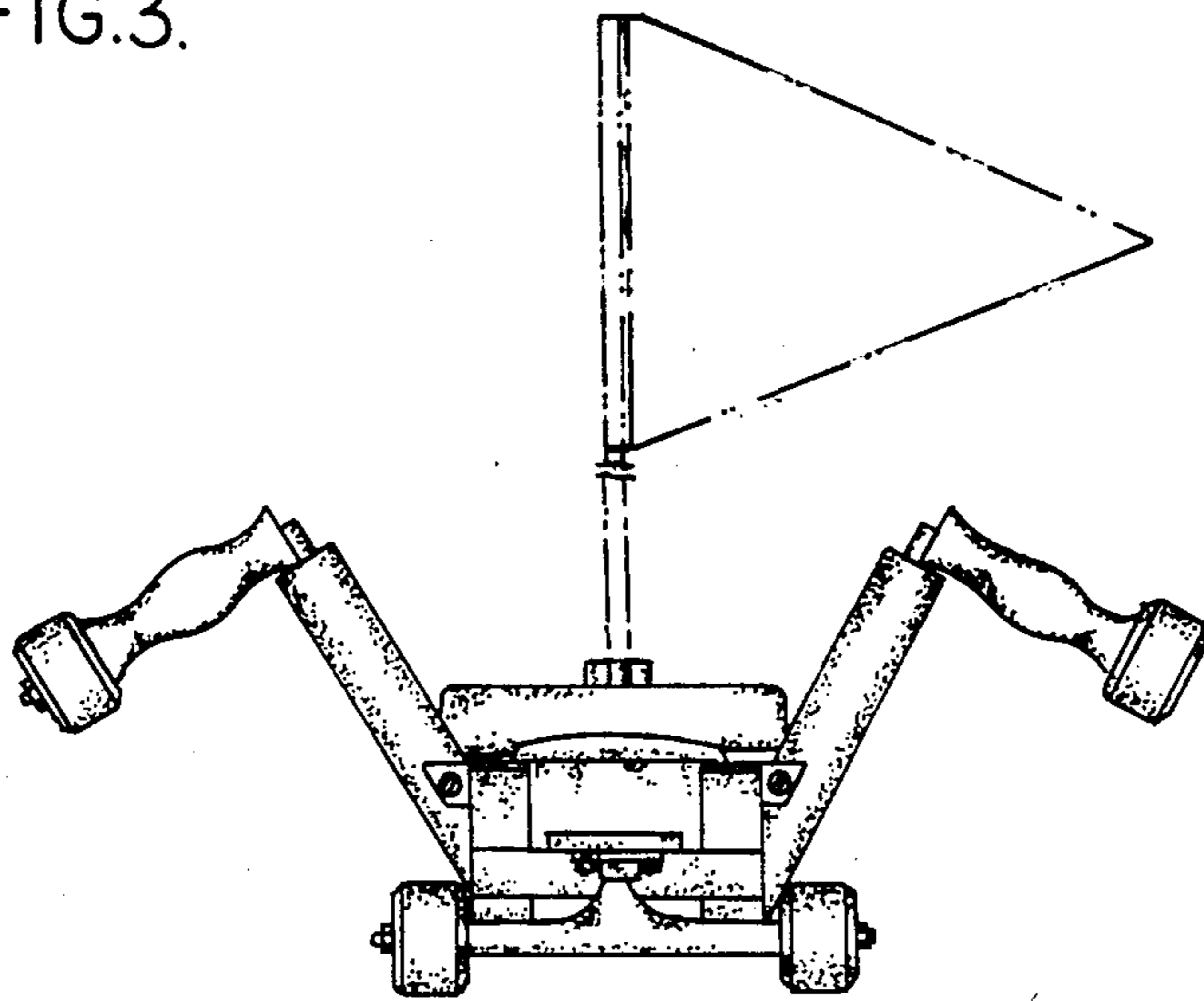

FIG. 4.

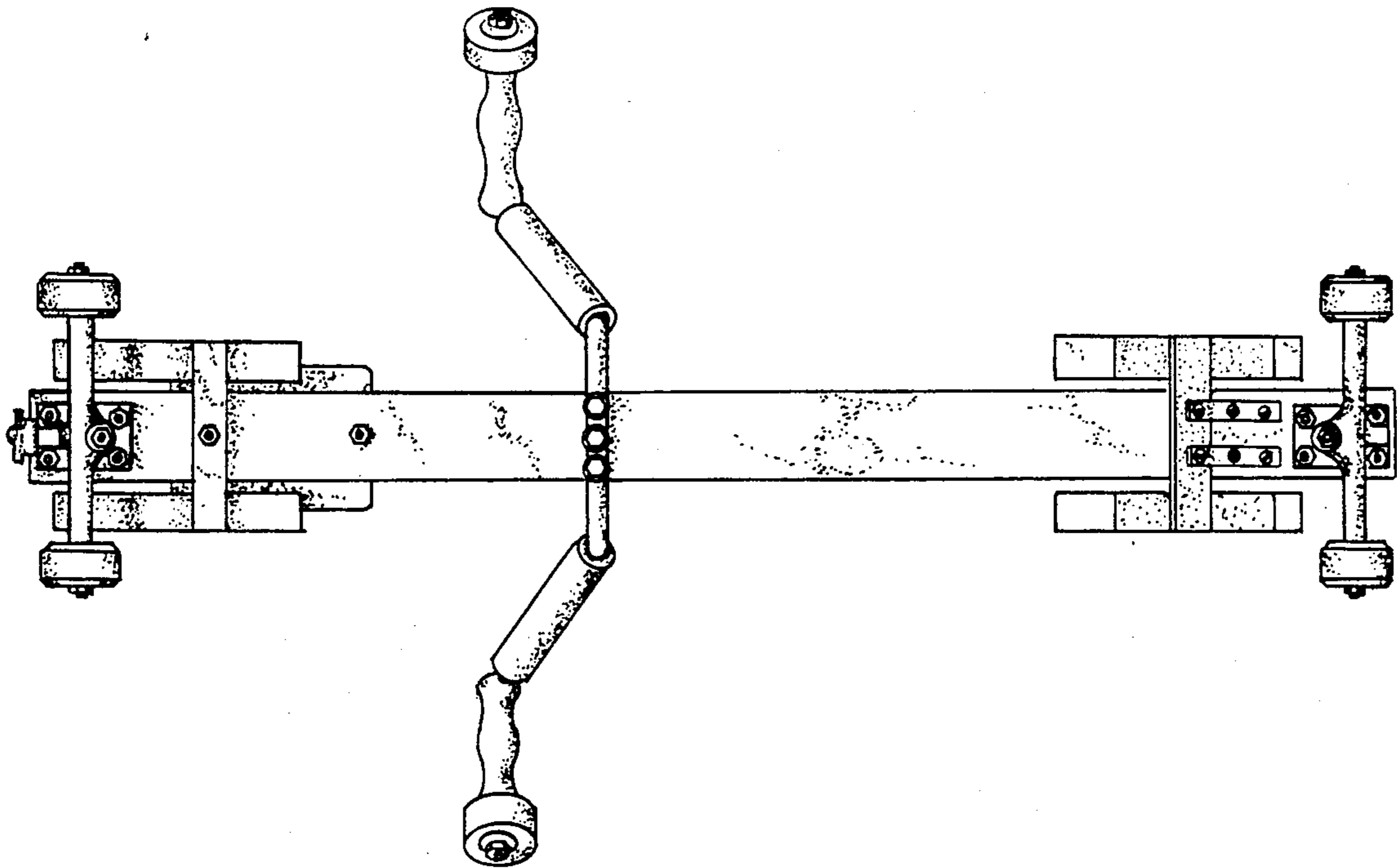

FIG. 5.

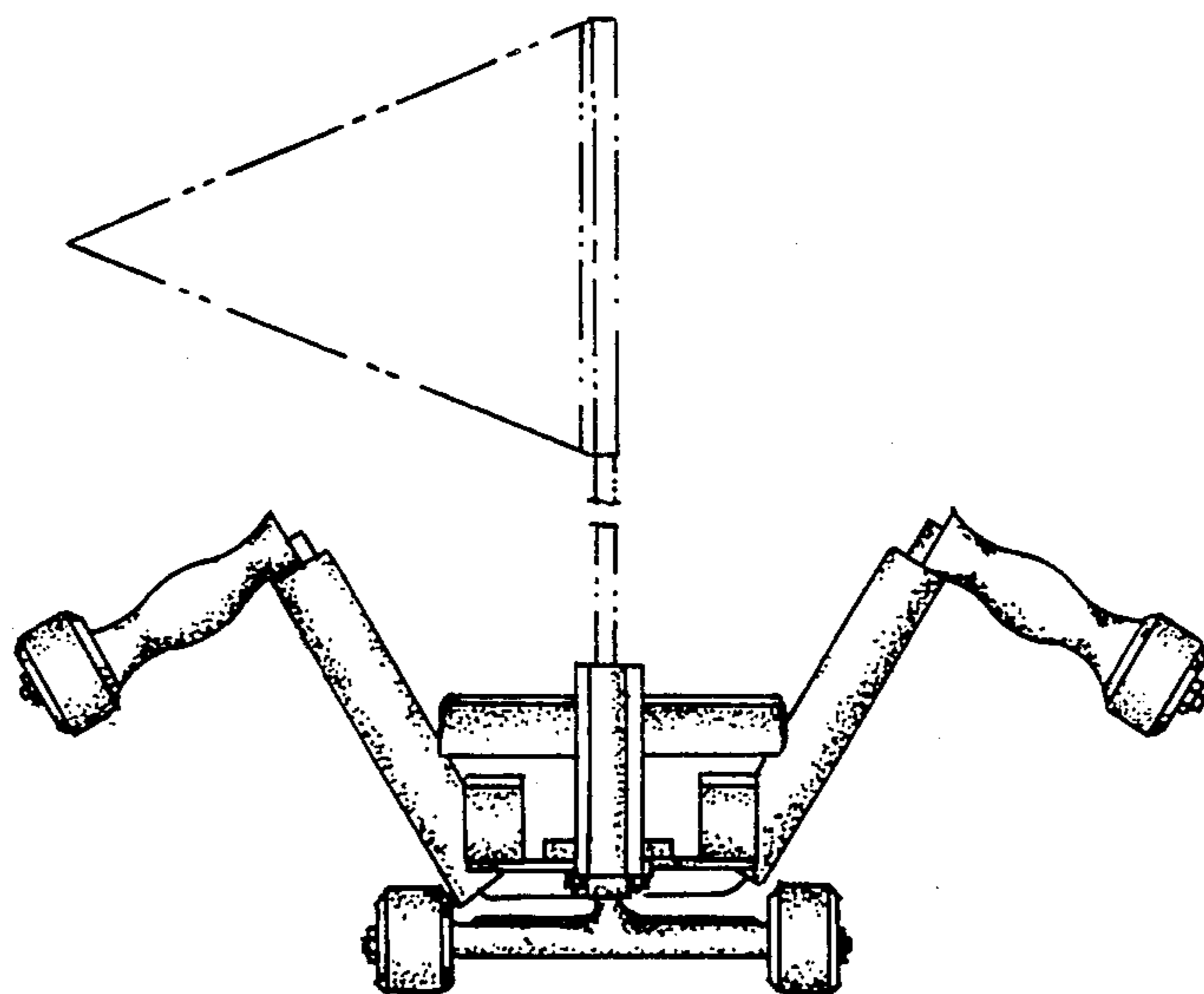

FIG. 6.