



US00D332939S

United States Patent [19]

[11] Patent Number: **Des. 332,939**

McDonough, Jr.

[45] Date of Patent: **** Feb. 2, 1993**

[54] WELDABLE GROUNDING CLAMP

4,776,808 10/1988 Davidson 439/435 X
5,004,437 4/1991 Walter et al. 439/791 X

[76] Inventor: **Robert M. McDonough, Jr.**, 105 S. Charlene Dr., Panama City, Fla. 32404

OTHER PUBLICATIONS

Trident 31 on p. 699 of American type Founders Company Catalog, 1902.

[**] Term: **14 Years**

Primary Examiner—Wallace R. Burke
Assistant Examiner—Joel Sincavage
Attorney, Agent, or Firm—Leon Gilden

[21] Appl. No.: **567,548**

[22] Filed: **Aug. 15, 1990**

[57] CLAIM

[52] U.S. Cl. **D13/149; D8/396**

The ornamental design for a weldable grounding clamp, as shown and described.

[58] Field of Search **D13/133, 149; D8/394, D8/396, 397; 439/391, 435, 721, 791, 803; 24/277; 248/214, 229, 231.7, 316.1**

DESCRIPTION

[56] References Cited

FIG. 1 is a front elevational view of the weldable grounding clamp showing my new design; FIG. 2 is a rear elevational view thereof; FIG. 3 is a left side elevational view thereof; FIG. 4 is a right side elevational view thereof; FIG. 5 is a top plan view thereof; FIG. 6 is a bottom plan view thereof; FIG. 7 is a front and upper left perspective view thereof; and, FIG. 8 is a rear and lower right perspective thereof.

U.S. PATENT DOCUMENTS

D. 26,639	2/1987	Stivers	D8/396
D. 228,442	9/1973	Edwards	D8/396
D. 296,546	7/1988	Sachs	D8/394 X
2,576,055	11/1951	Walsh	D13/149 X
2,719,345	10/1955	Riker	D8/396 X
4,403,378	9/1983	Engman	D8/396 X
4,407,050	10/1983	Offtender	D8/396 X
4,415,188	11/1983	Ginter, Jr.	24/277 X

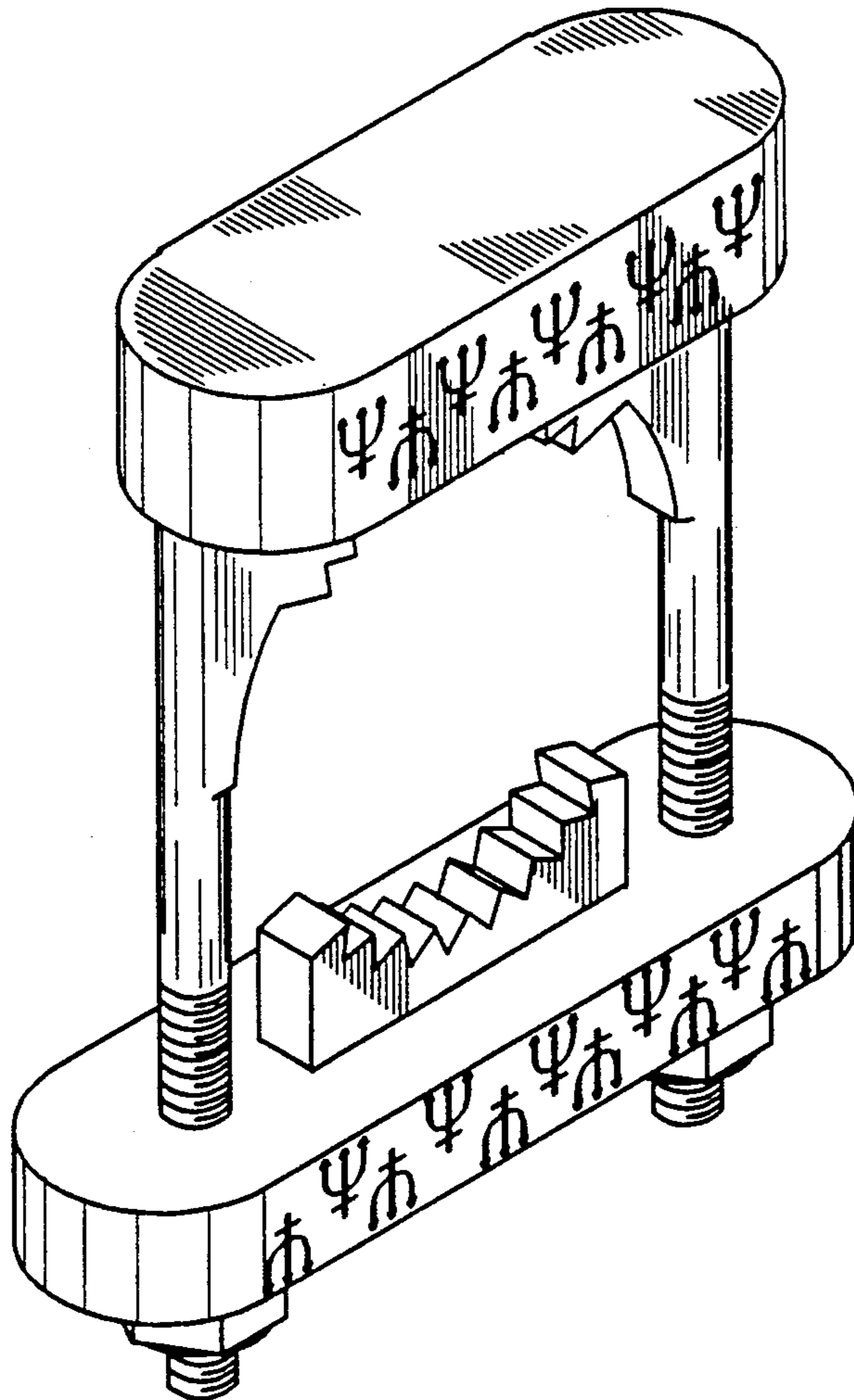

FIG. 1

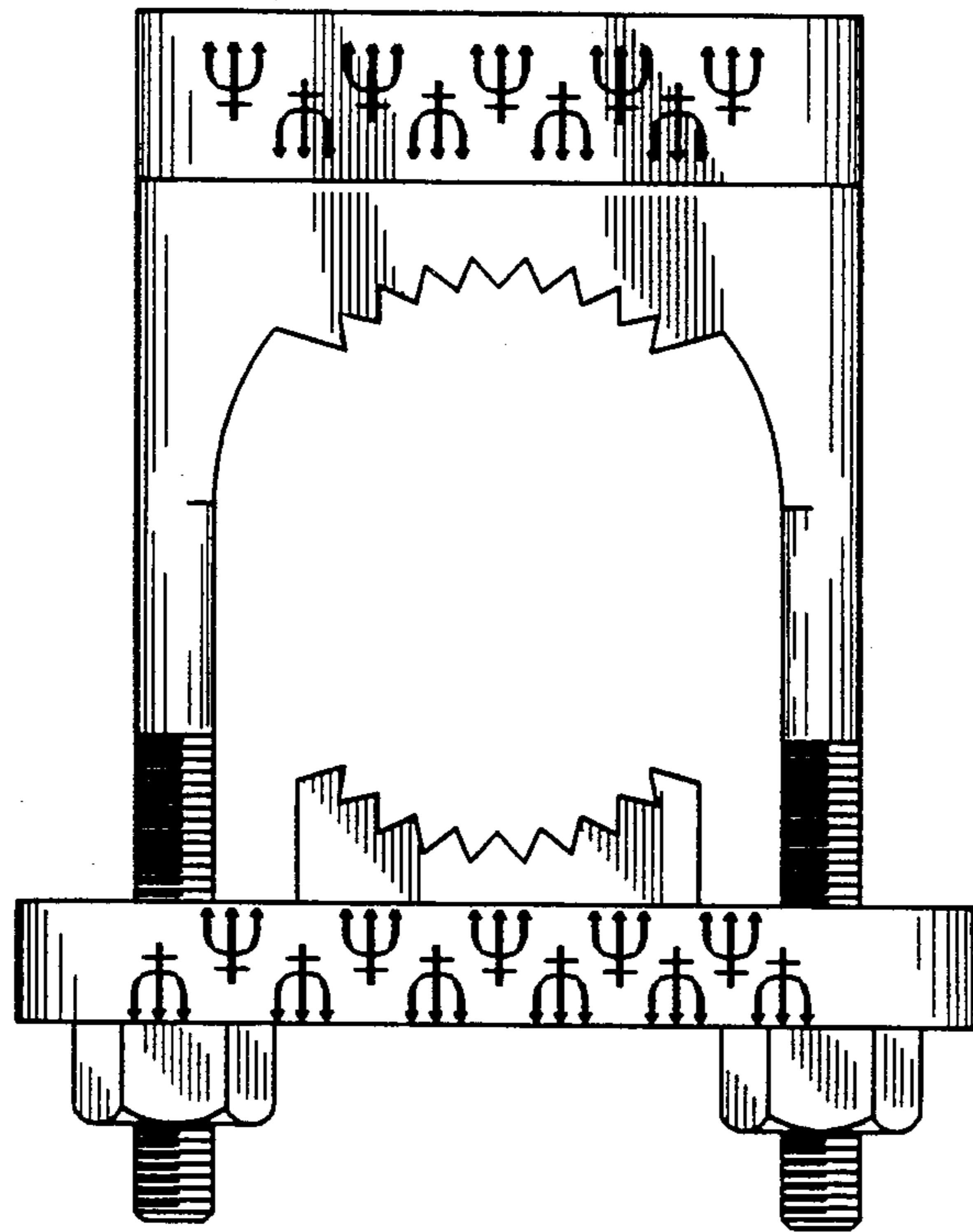

FIG. 2

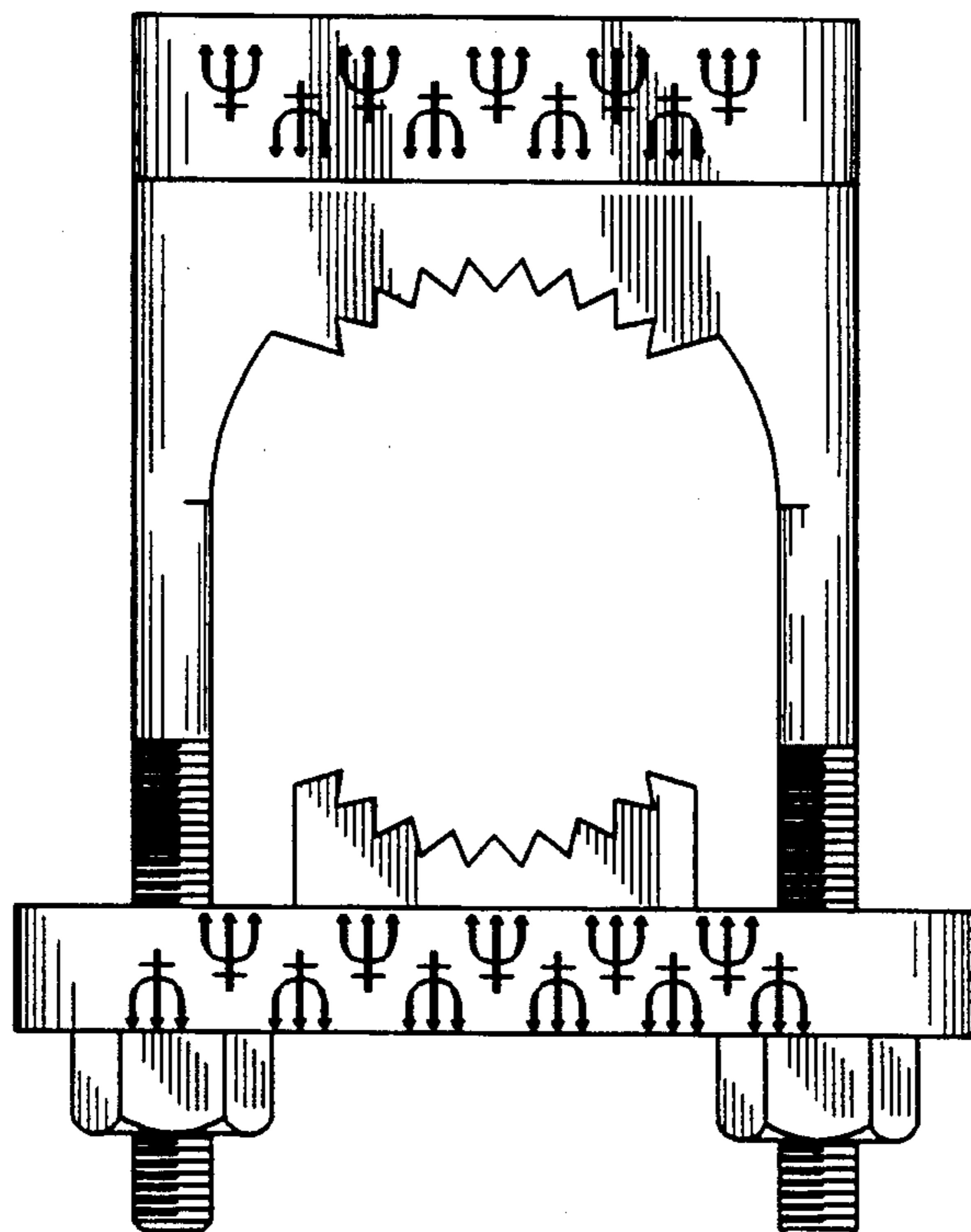

FIG. 3

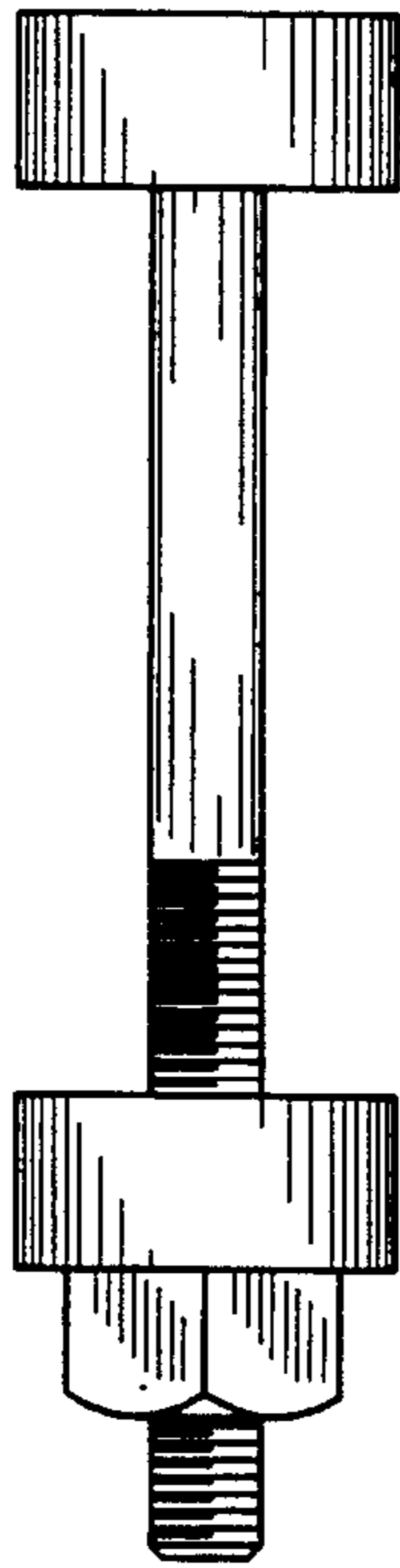

FIG. 4

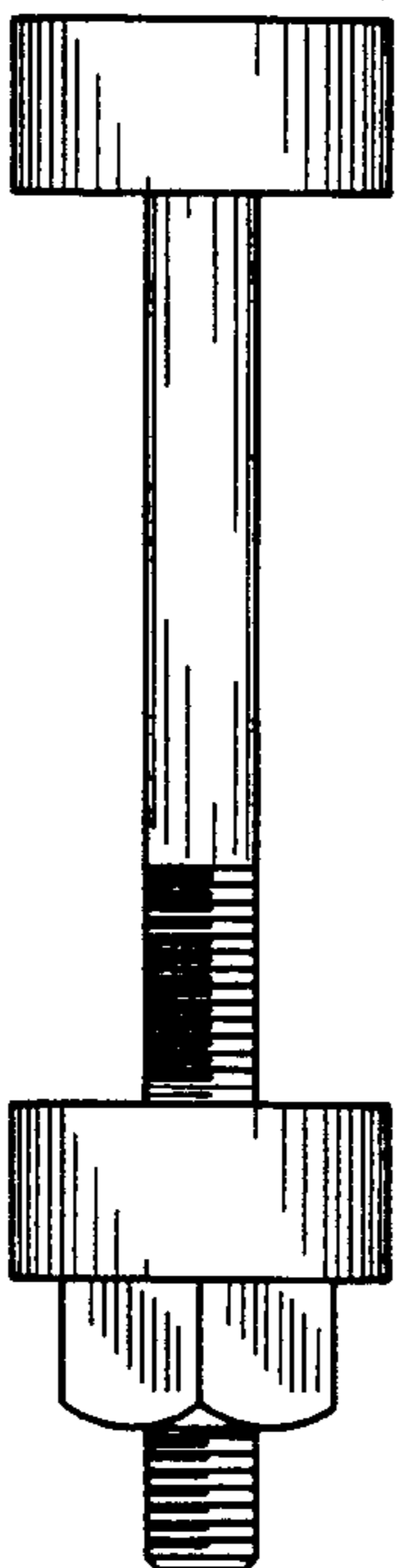

FIG. 5

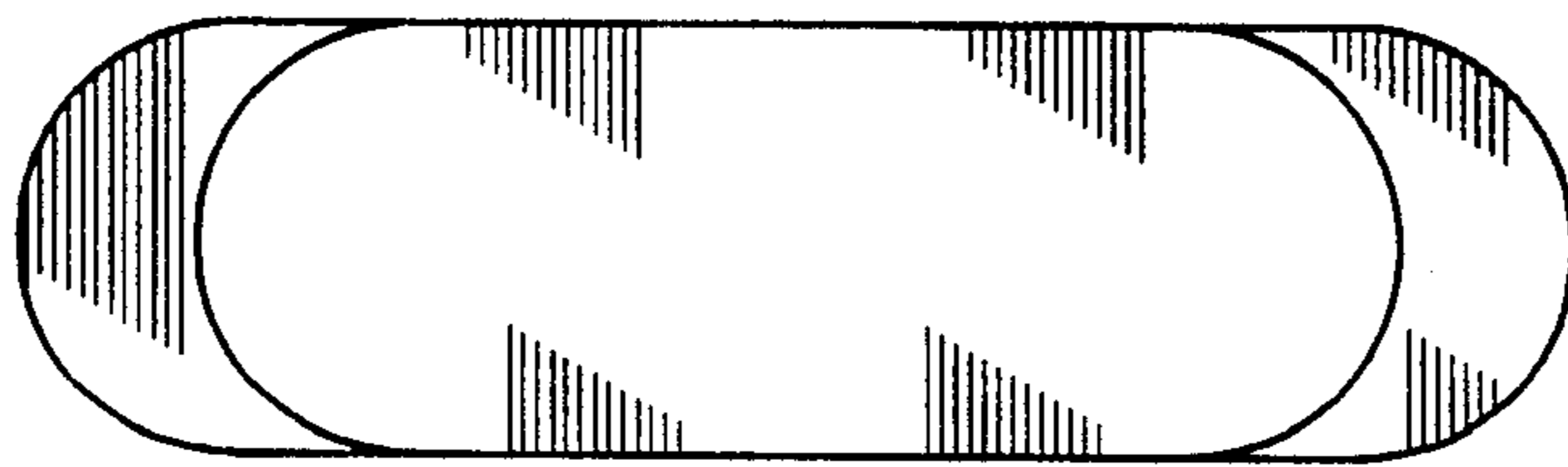

FIG. 6

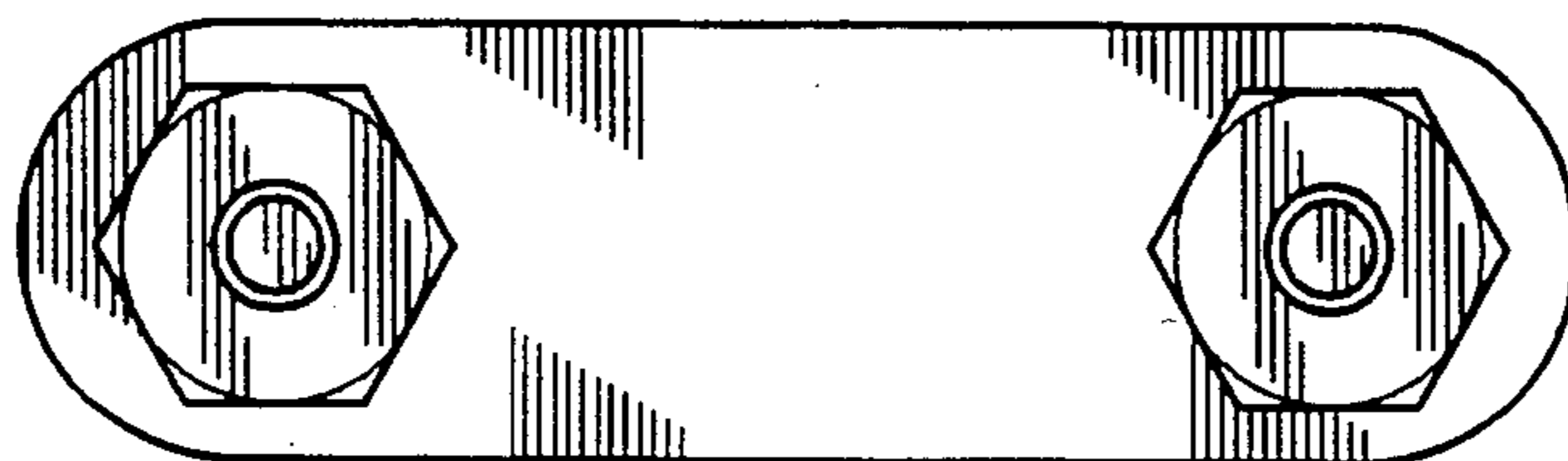

FIG. 7

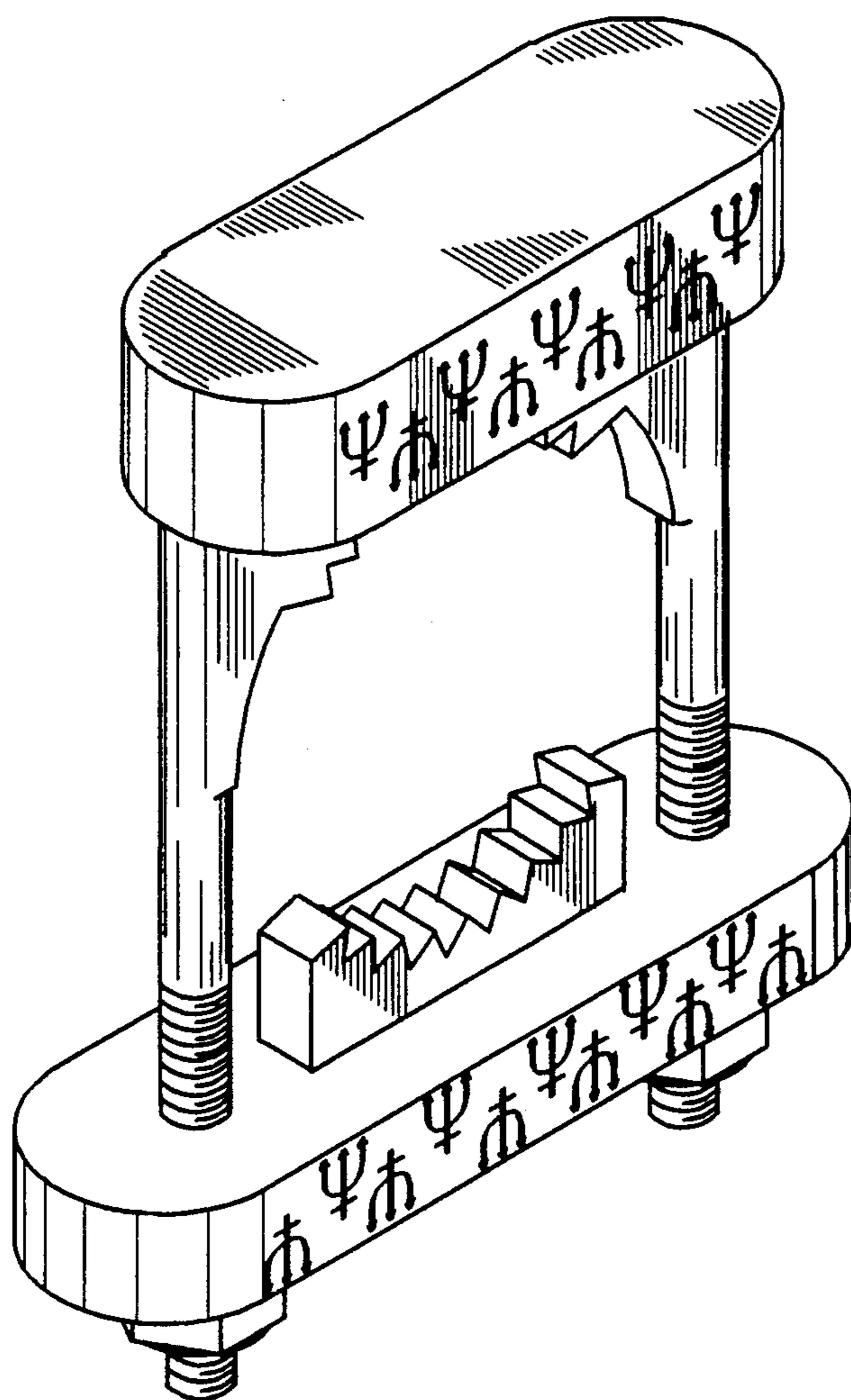

FIG. 8

