



US00D332764S

United States Patent [19] Chandler

[11] Patent Number: **Des. 332,764**
[45] Date of Patent: **** Jan. 26, 1993**

[54] **ALL TERRAIN MOTOR VEHICLE**
[75] Inventor: **Graeme A. Chandler, Morley, Australia**
[73] Assignee: **Altrack Limited, West Perth, Australia**
[**] Term: **14 Years**
[21] Appl. No.: **663,646**
[22] Filed: **Mar. 4, 1991**
[30] Foreign Application Priority Data
Sep. 3, 1990 [AU] Australia 2864/90
[52] U.S. Cl. **D12/3**
[58] Field of Search **D12/3; 180/184; D21/131**

D. 324,356 3/1992 Rollinson et al. D12/3
3,692,130 9/1972 Stacy, Jr. 180/184
3,771,615 11/1973 Rieli D12/3
3,777,829 12/1973 Rogers 180/184

Primary Examiner—Wallace R. Burke
Assistant Examiner—Melody Brown
Attorney, Agent, or Firm—Bereskin & Parr

[57] CLAIM

The ornamental design for an all terrain motor vehicle, as shown and described.

DESCRIPTION

FIG. 1 is a front and side perspective view of an all terrain motor vehicle showing my new design;
FIG. 2 is a rear and side perspective view thereof;
FIG. 3 is a side elevation view thereof;
FIG. 4 is a view from the other side of the motor vehicle;
FIG. 5 is a front elevation view thereof;
FIG. 6 is a rear elevation view thereof; and,
FIG. 7 is a top plan view thereof.

[56] **References Cited**
U.S. PATENT DOCUMENTS
D. 314,388 2/1991 Brewer et al. D12/1

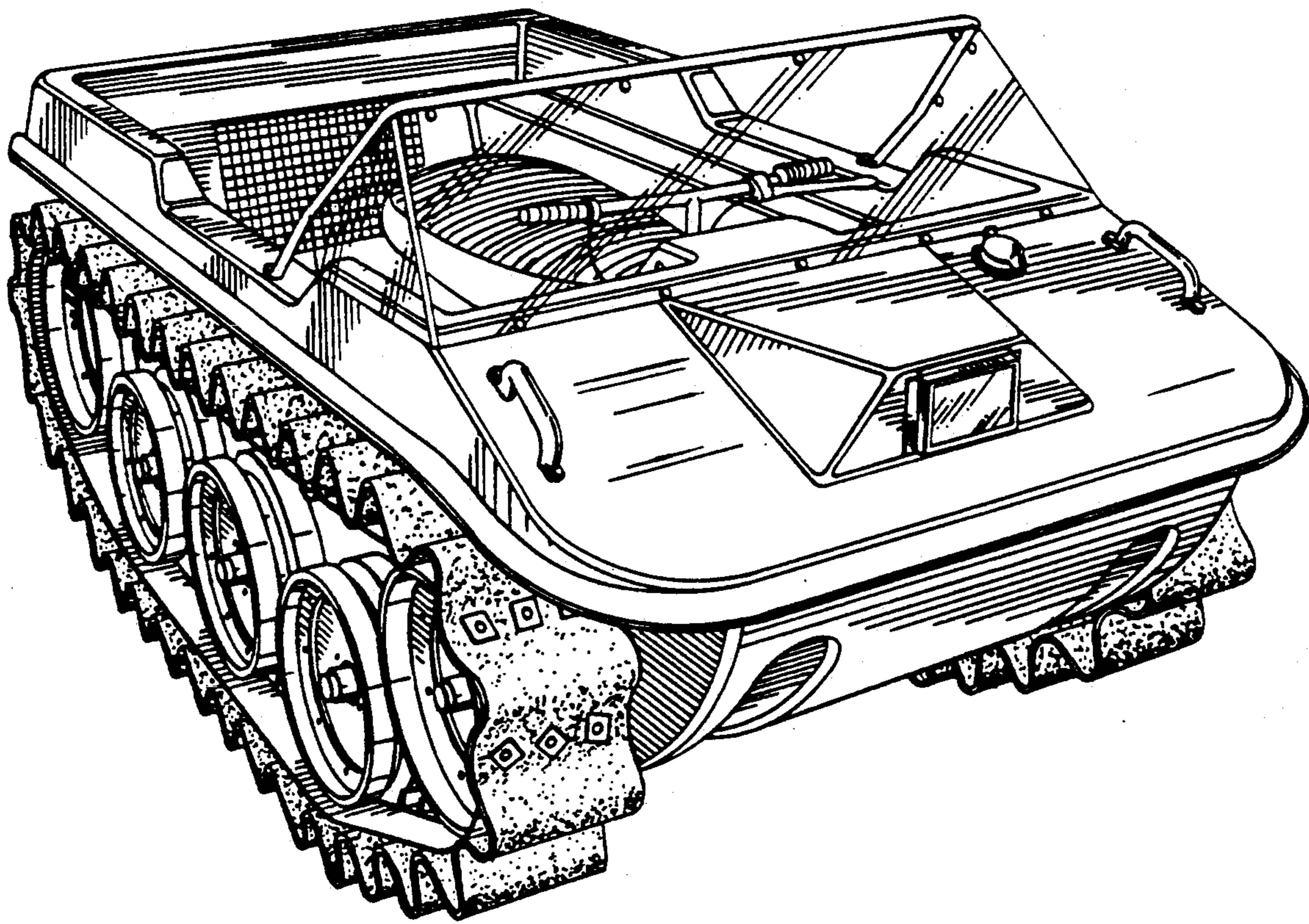

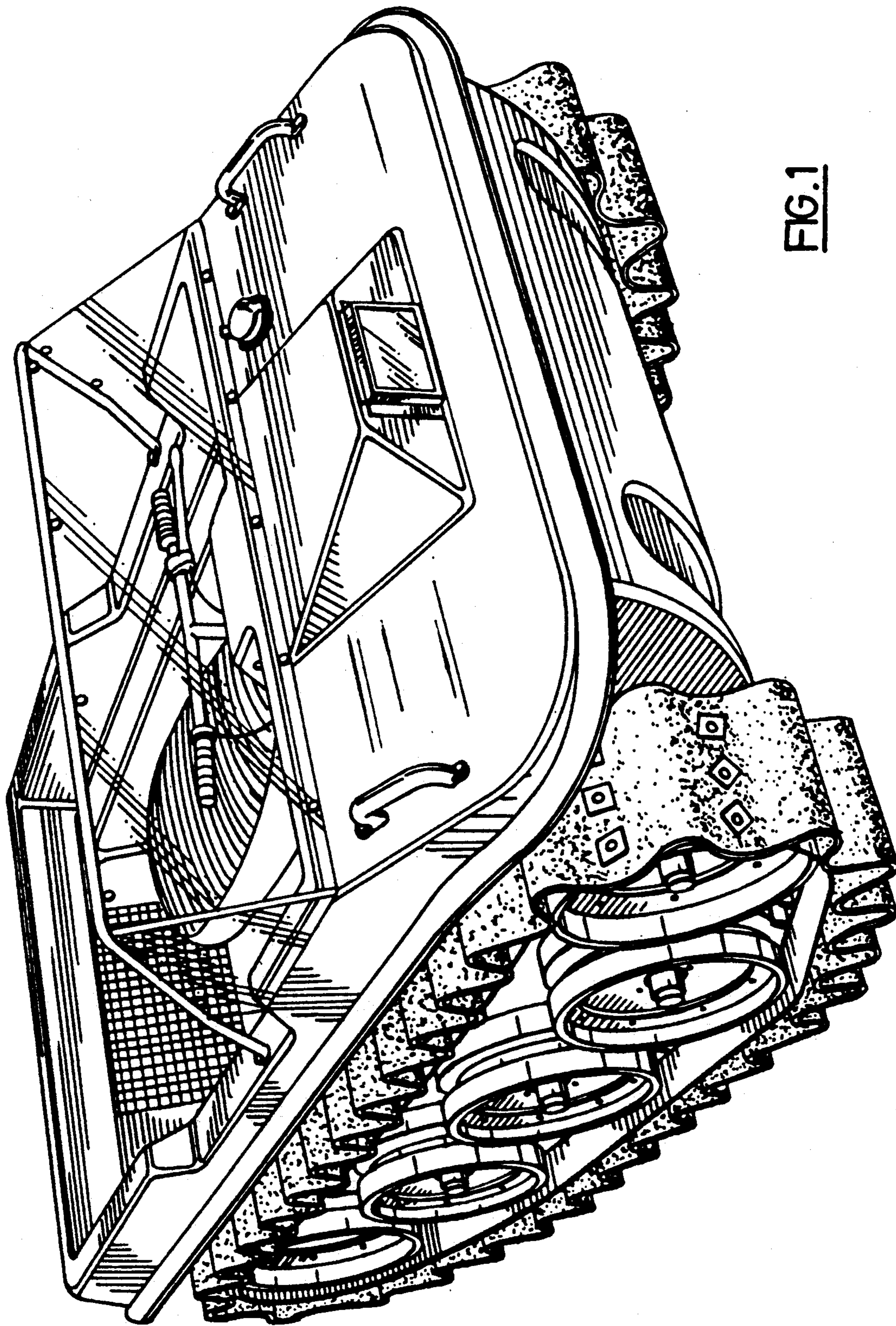

FIG. 1

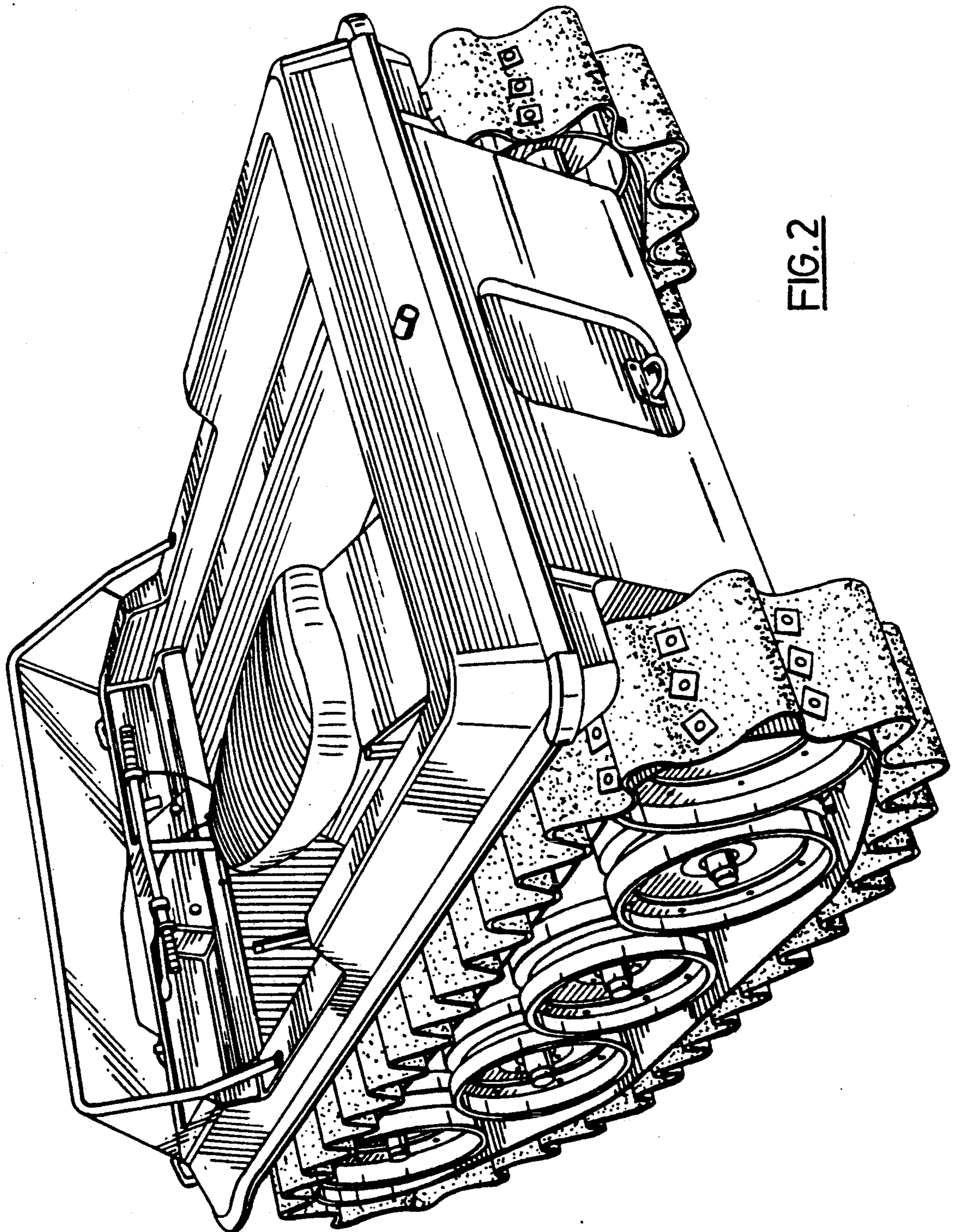

FIG. 2

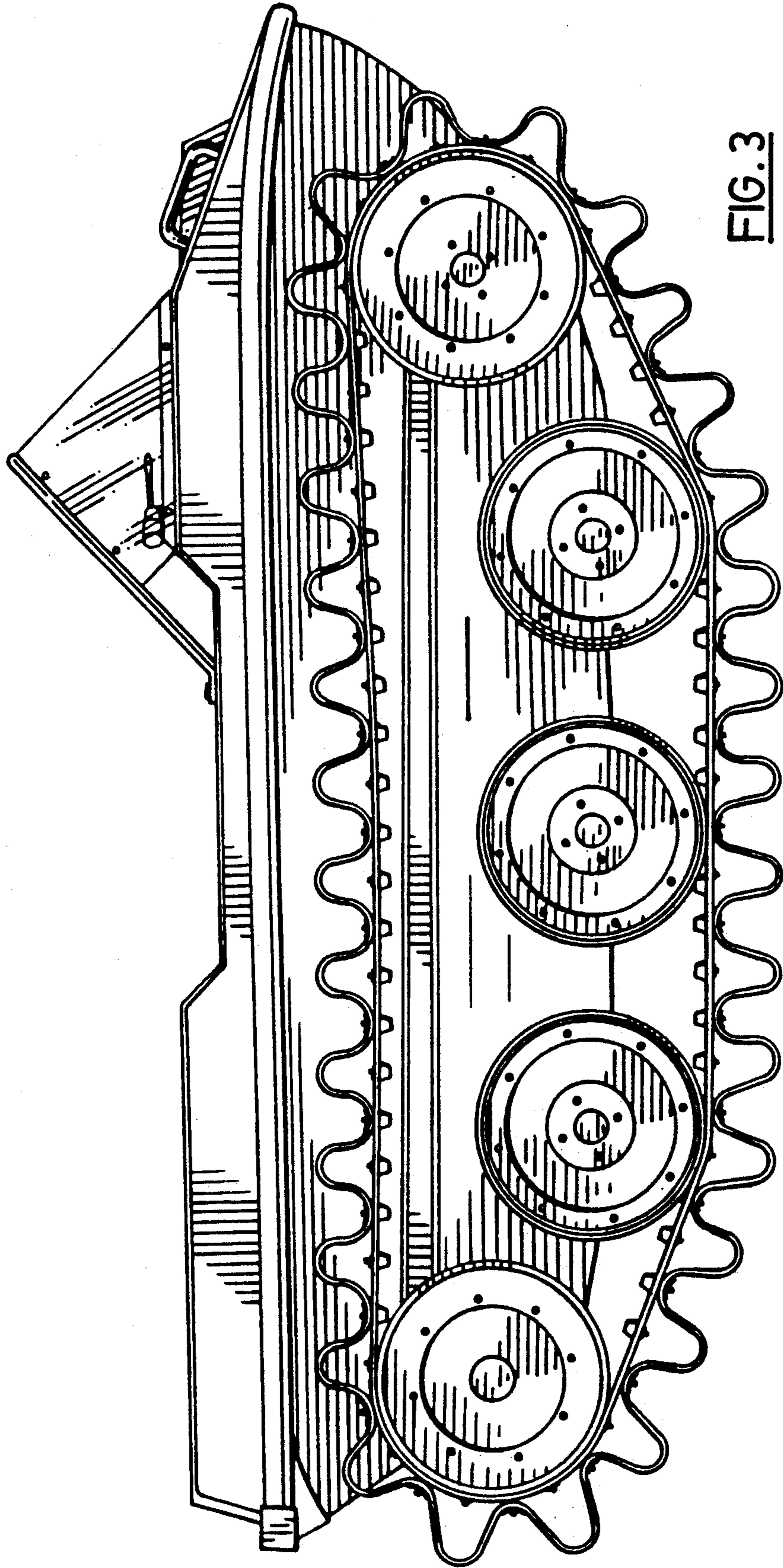

FIG. 3

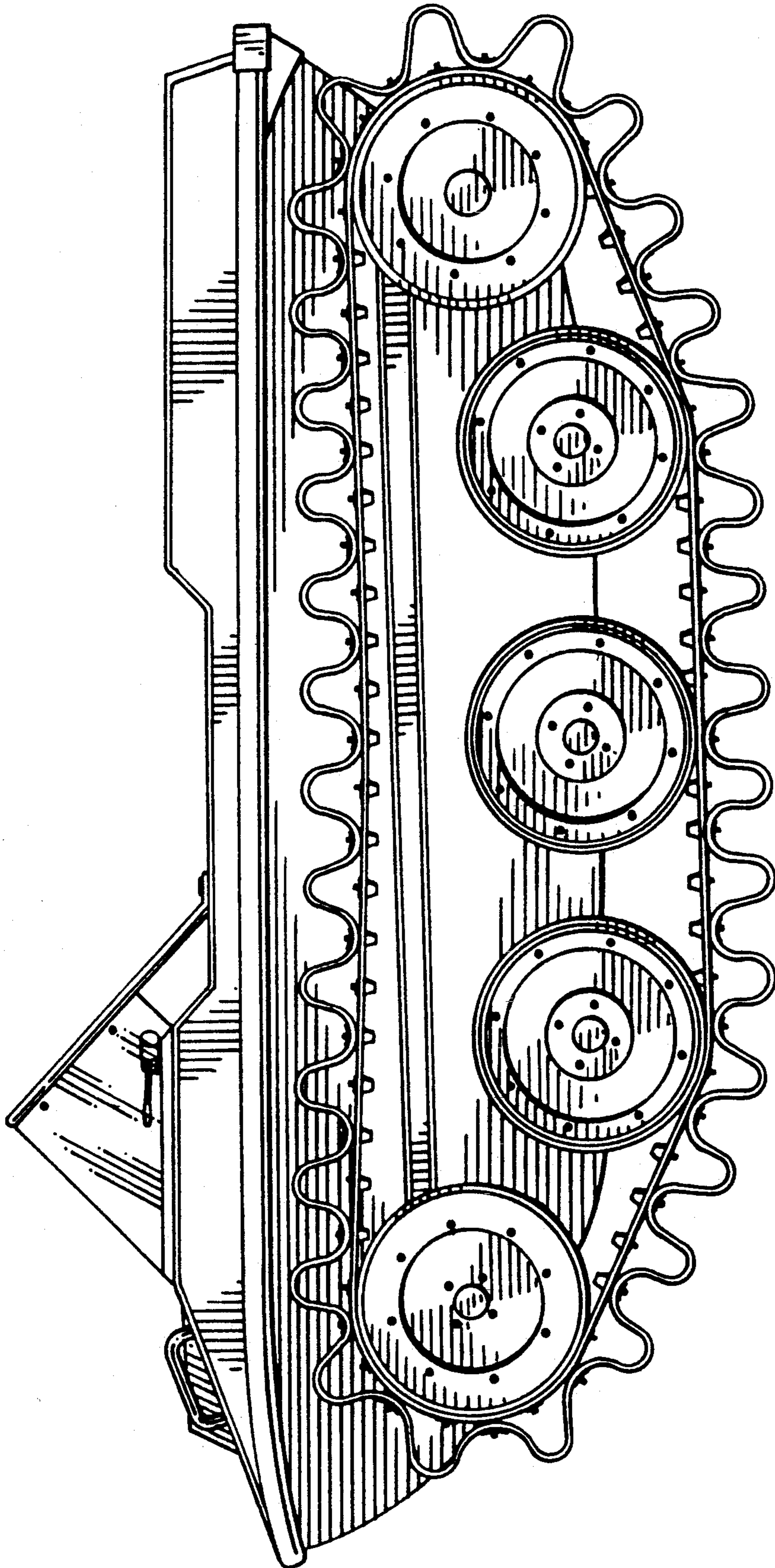

FIG. 4

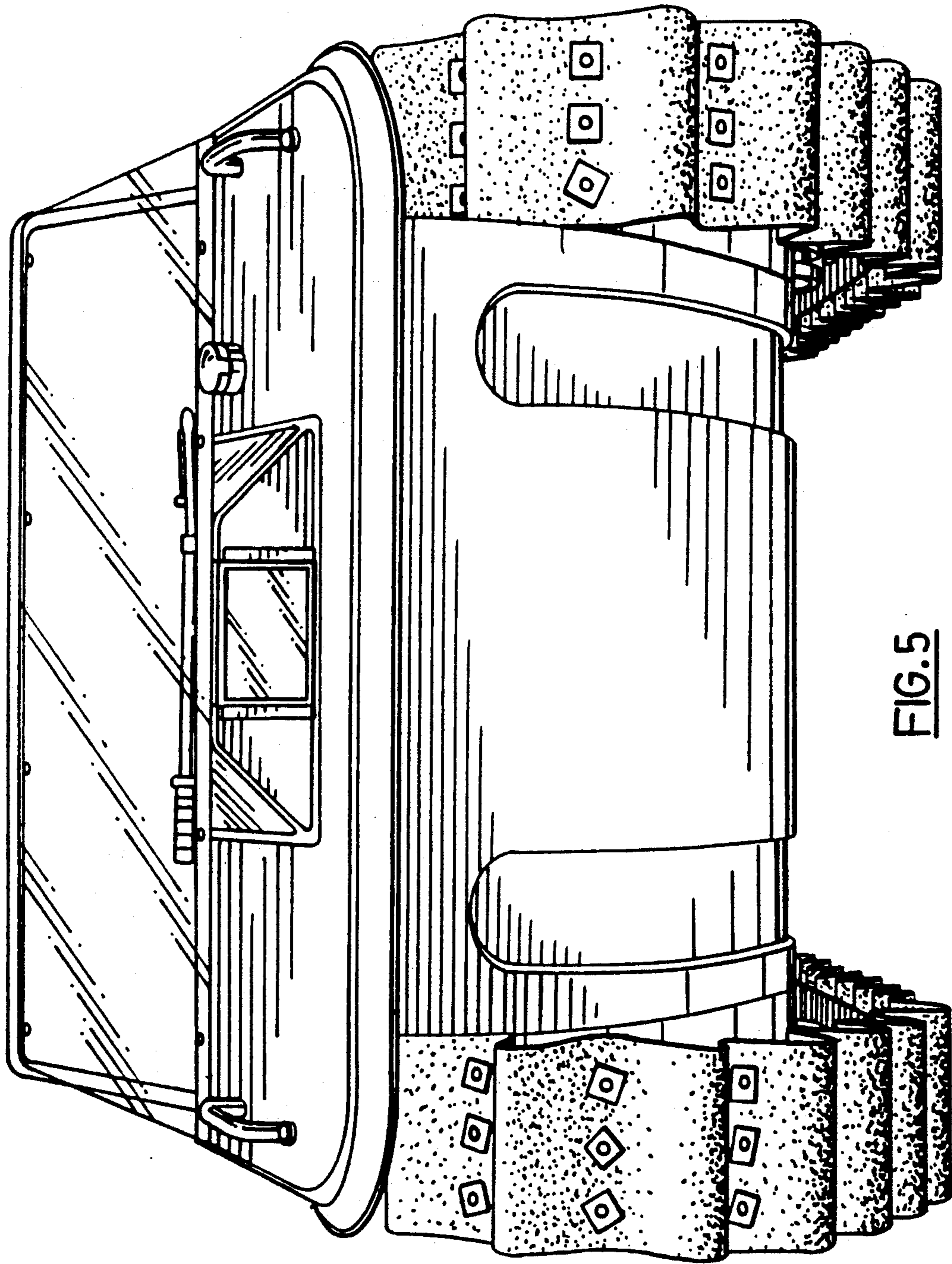

FIG. 5

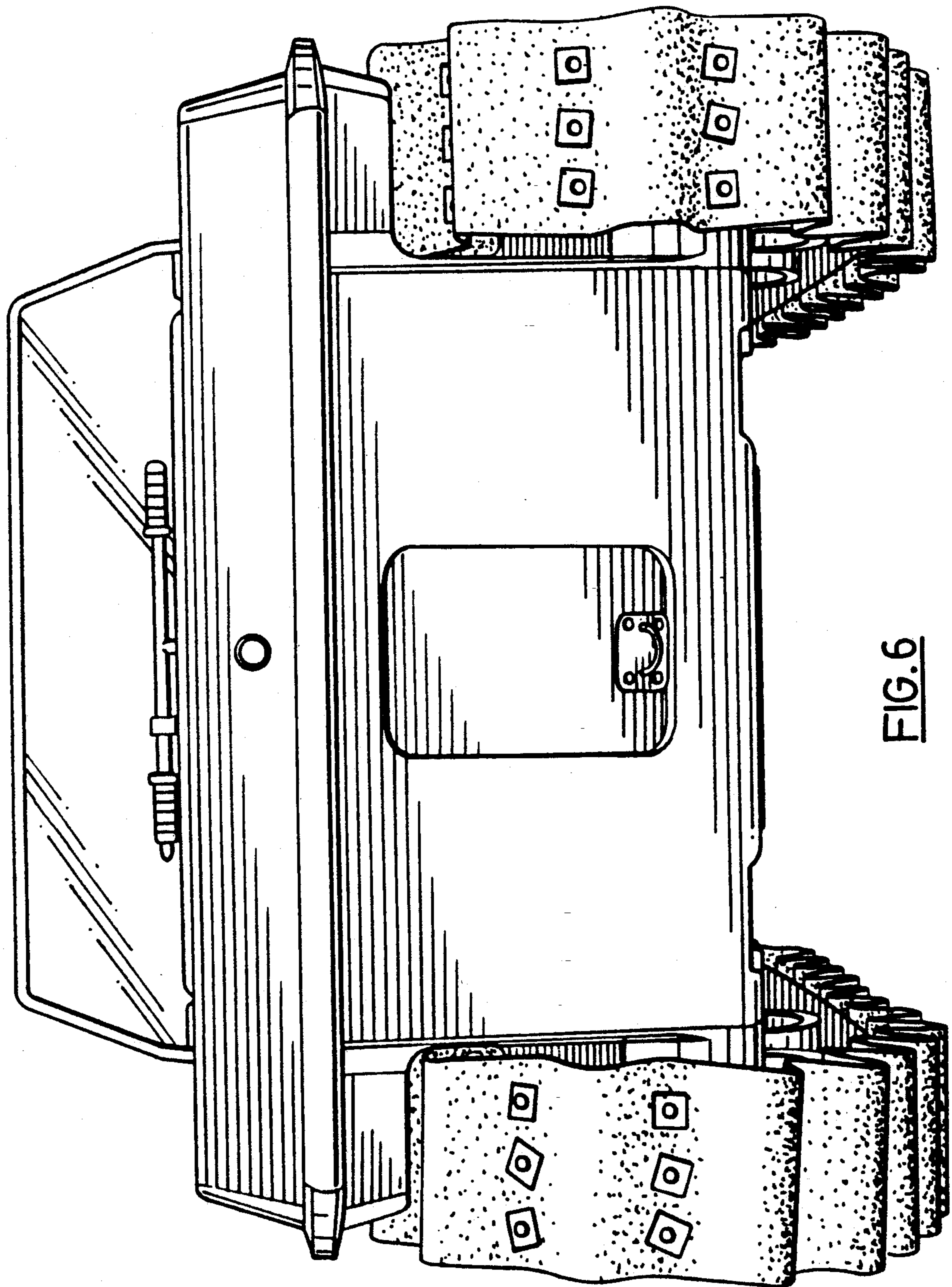

FIG. 6

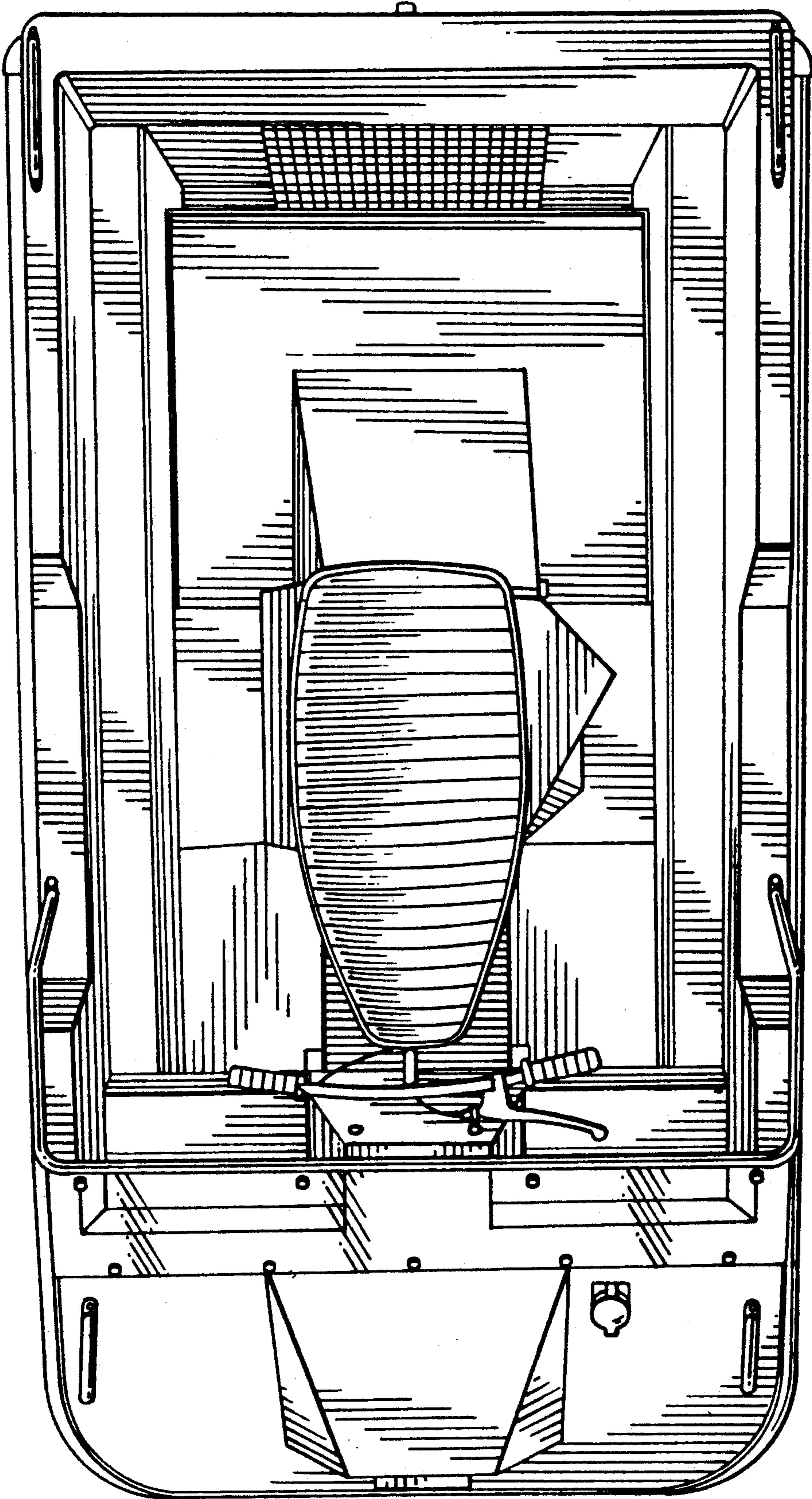

FIG. 7