



US00D332734S

United States Patent [19]

[11] Patent Number: **Des. 332,734**

Fushiya et al.

[45] Date of Patent: **** Jan. 26, 1993**

[54] **POLISHER**

[75] Inventors: **Fusao Fushiya; Hideki Ohkubo**, both of Anjo, Japan

[73] Assignee: **Makita Electric Works, Ltd.**, Anjo, Japan

[**] Term: **14 Years**

[21] Appl. No.: **507,178**

[22] Filed: **Apr. 10, 1990**

[30] **Foreign Application Priority Data**

Oct. 24, 1989 [JP] Japan 1-38824

[52] U.S. Cl. **D8/62; D32/19**

[58] Field of Search D32/1, 14.1, 15-17, D32/19-22; 15/320, 321, 340.2, 340.3, 340.4, 49.1, 50.1, 50.3, 52.1, 78, 79.1, 79.2, 82, 87, 230, 97.3; D4/102, 100, 137; D8/62

[56] **References Cited**

U.S. PATENT DOCUMENTS

- D. 254,231 2/1980 Burglin et al. D8/62
- D. 264,797 6/1982 Burglin et al. D8/62

- D. 270,515 9/1983 Dunlap D8/62
- D. 273,079 3/1984 Ibaraki D8/62
- D. 283,590 4/1986 Ibaraki D8/62
- D. 295,253 4/1988 Ashworth D8/62
- D. 312,714 12/1990 Simonelli et al. D32/19
- D. 313,094 12/1990 Itaya et al. D32/19
- D. 326,398 5/1992 Fushiya et al. D8/62

Primary Examiner—A. Hugo Word
Assistant Examiner—Ruth McInroy
Attorney, Agent, or Firm—Dennison, Meserole, Pollack & Scheiner

[57] **CLAIM**

The ornamental design for a polisher, as shown and described.

DESCRIPTION

FIG. 1 is a perspective view of a polisher showing our new design;
FIG. 2 is a front elevational view thereof;
FIG. 3 is a rear elevational view thereof;
FIG. 4 is a left side elevational view thereof;
FIG. 5 is a right side elevational view thereof;
FIG. 6 is a top plan view thereof; and,
FIG. 7 is a bottom plan view thereof.

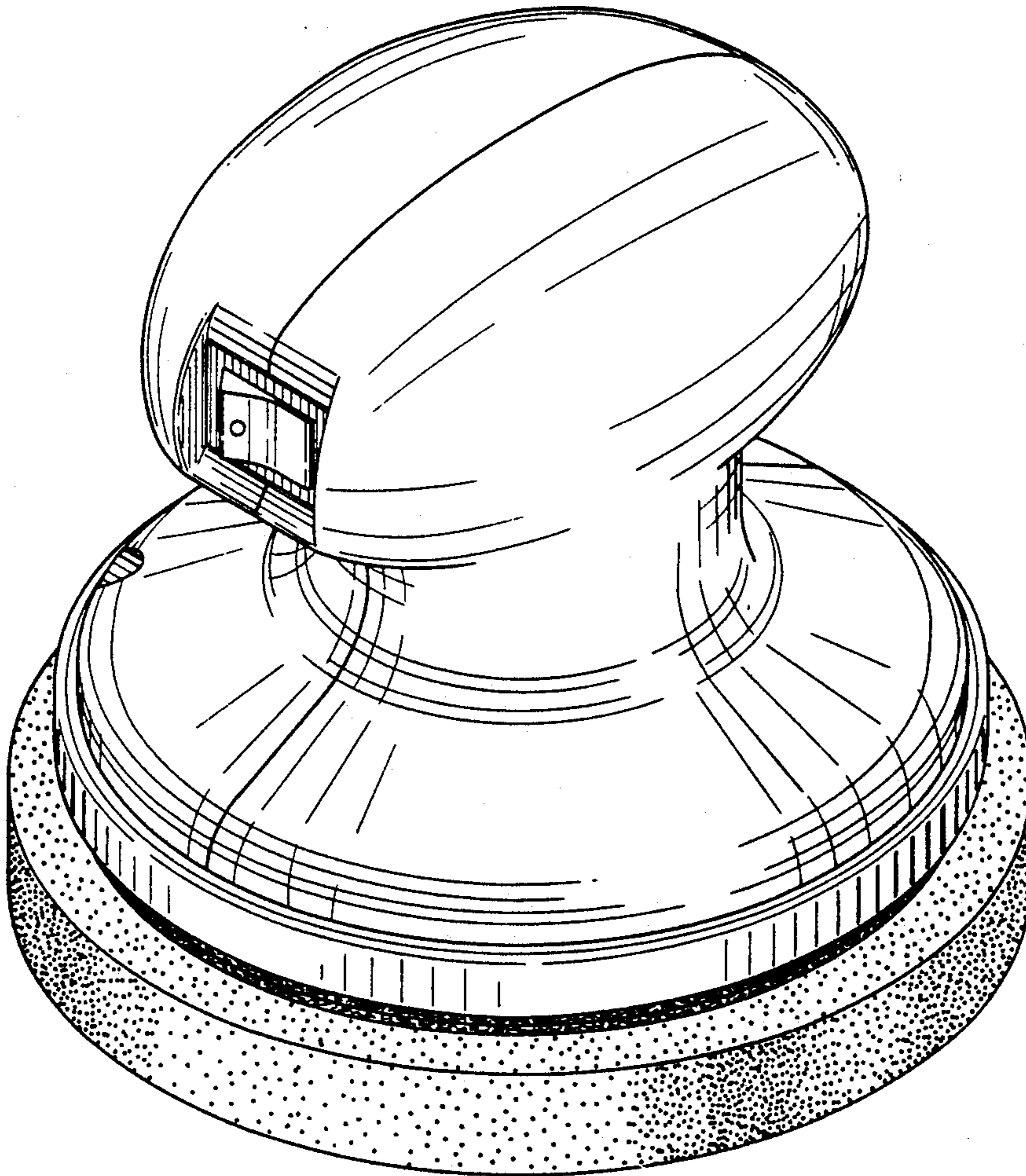

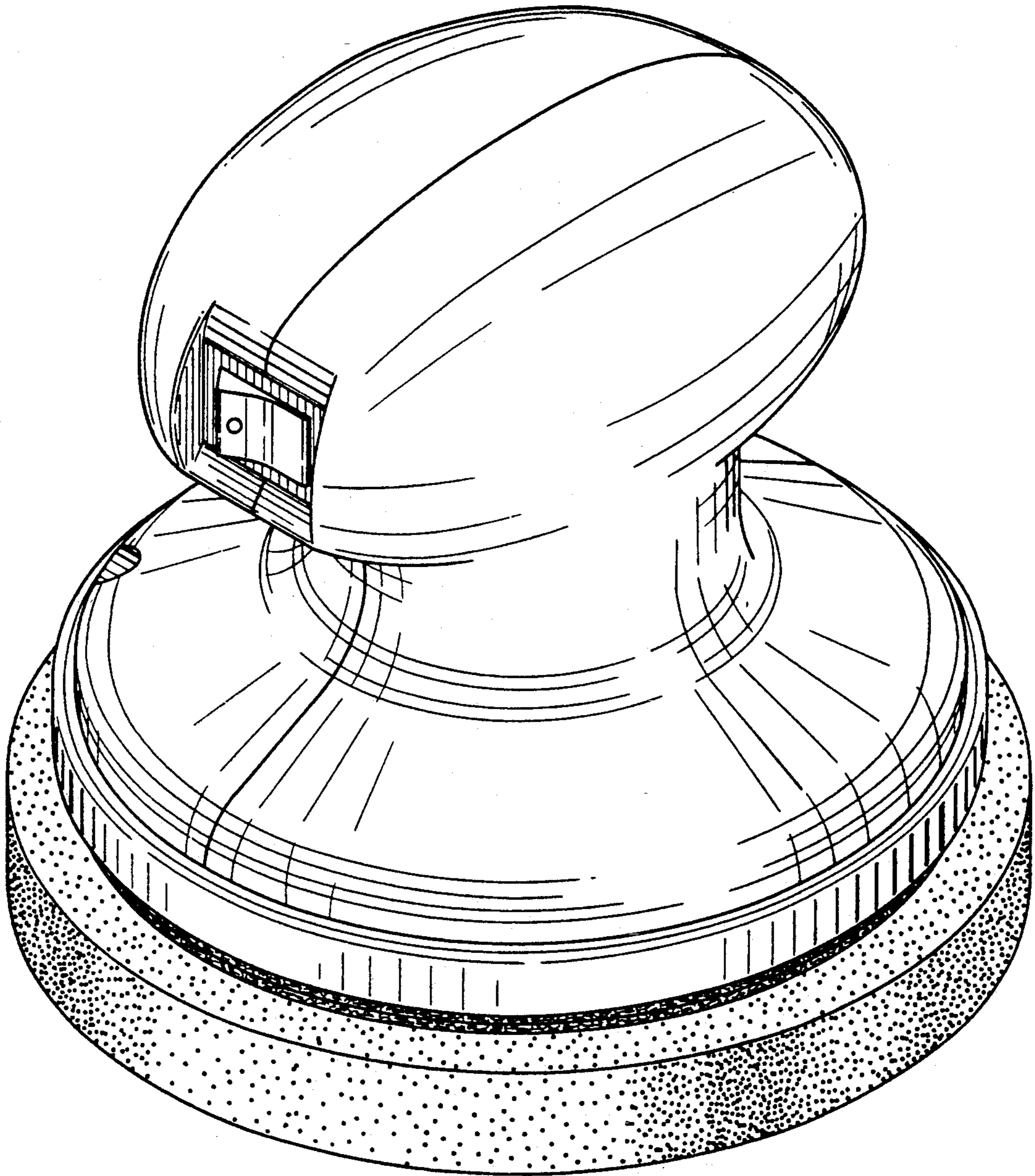

FIG. 1

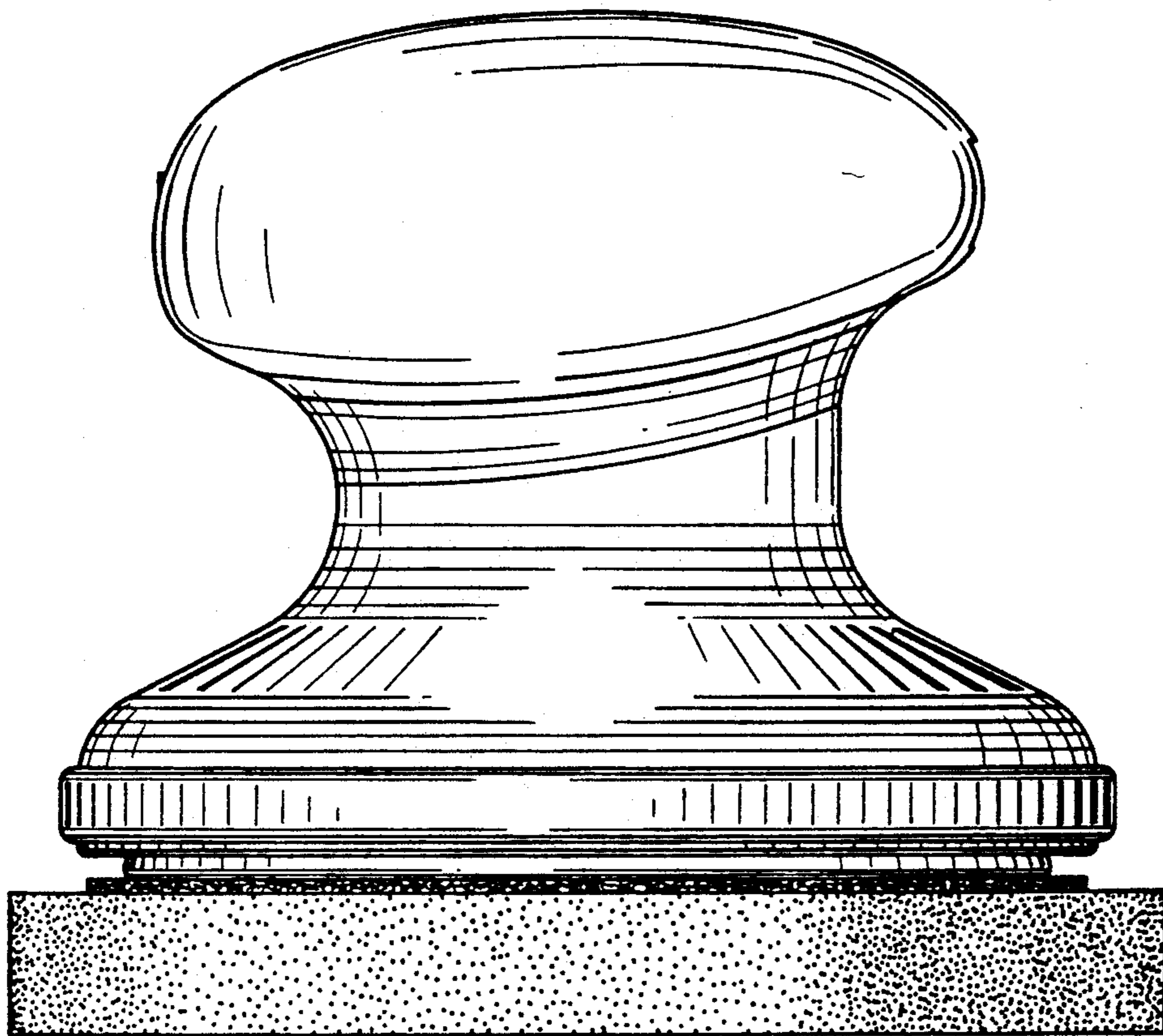

FIG. 2

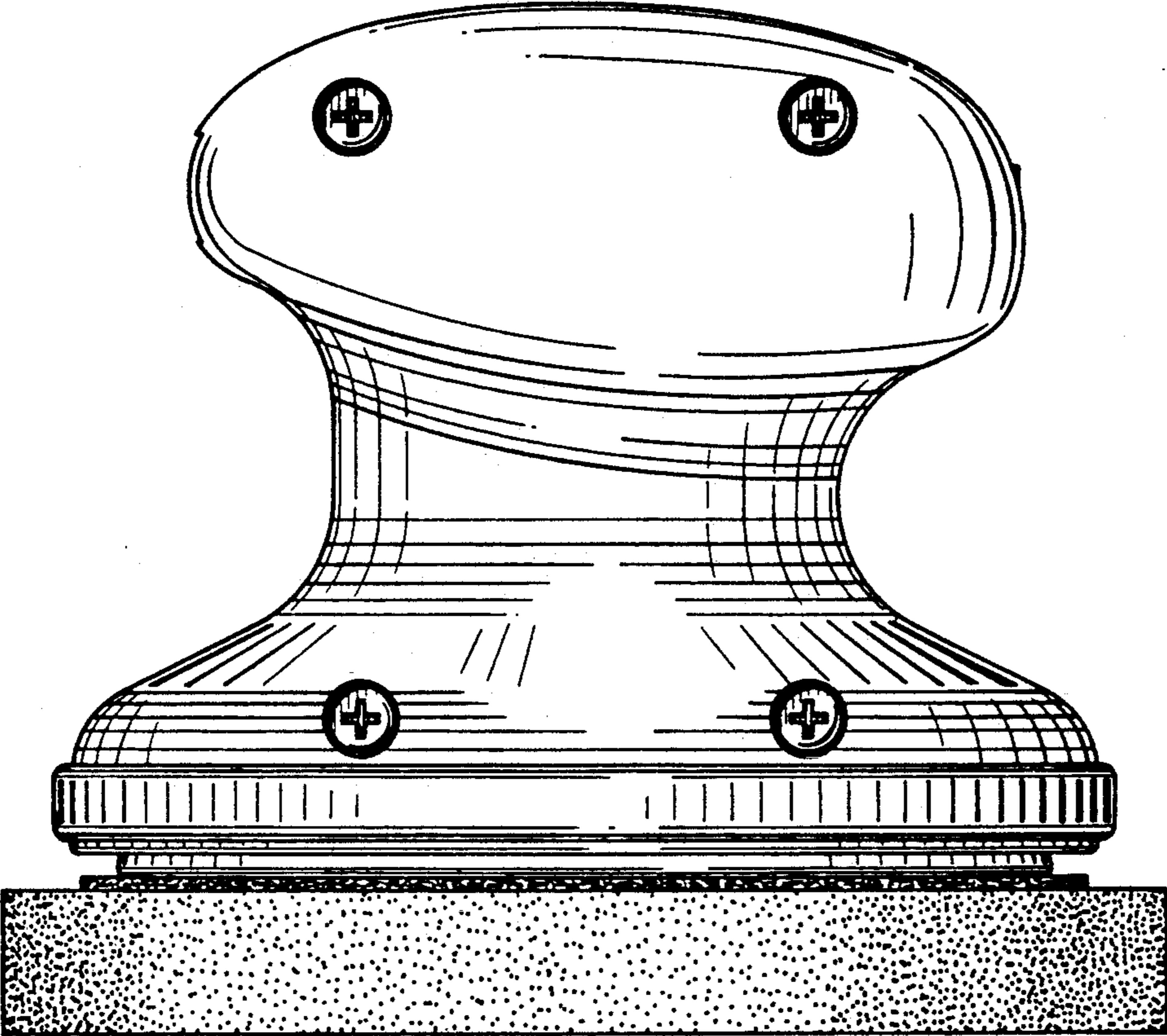

FIG. 3

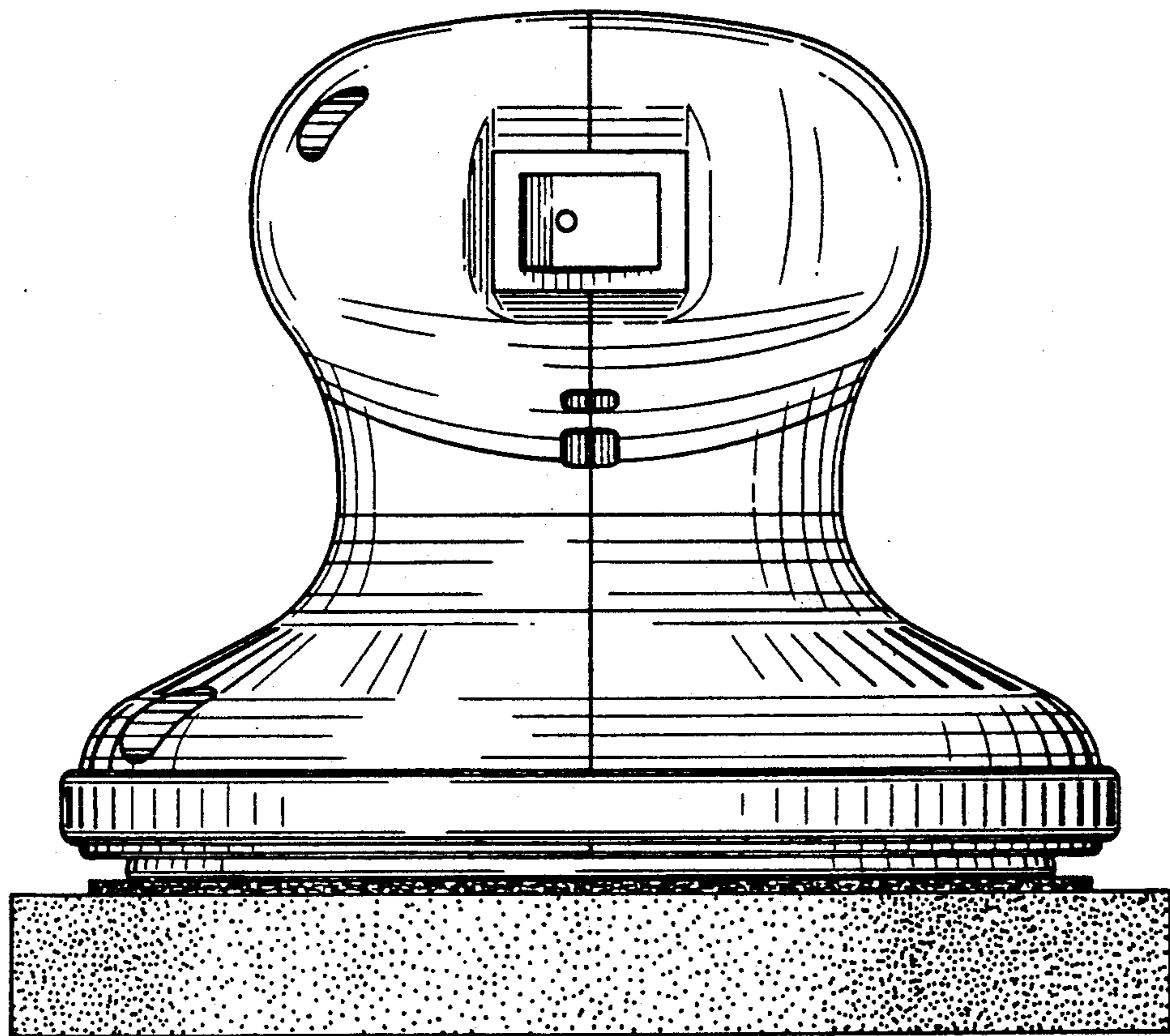

FIG. 4

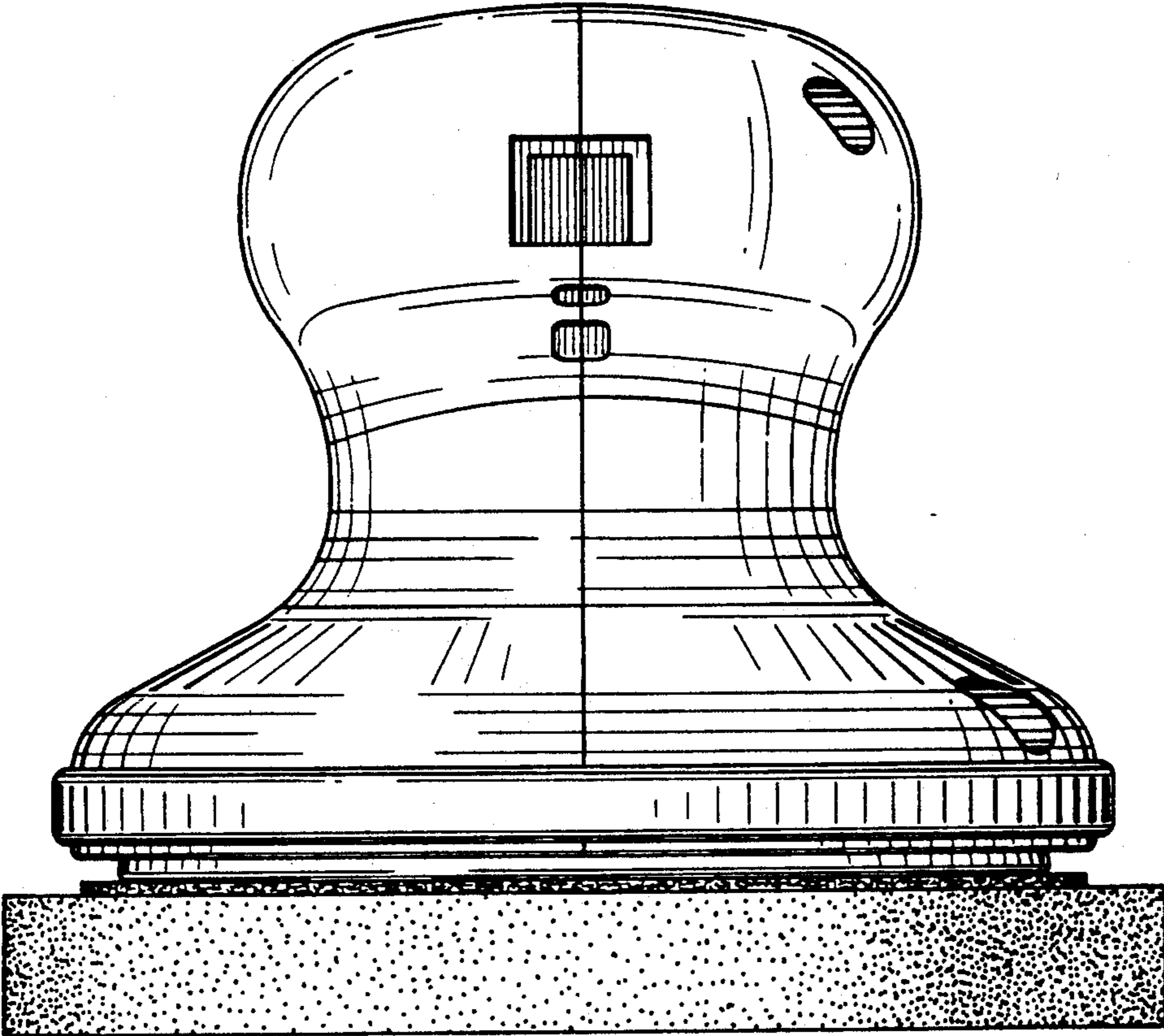

FIG. 5

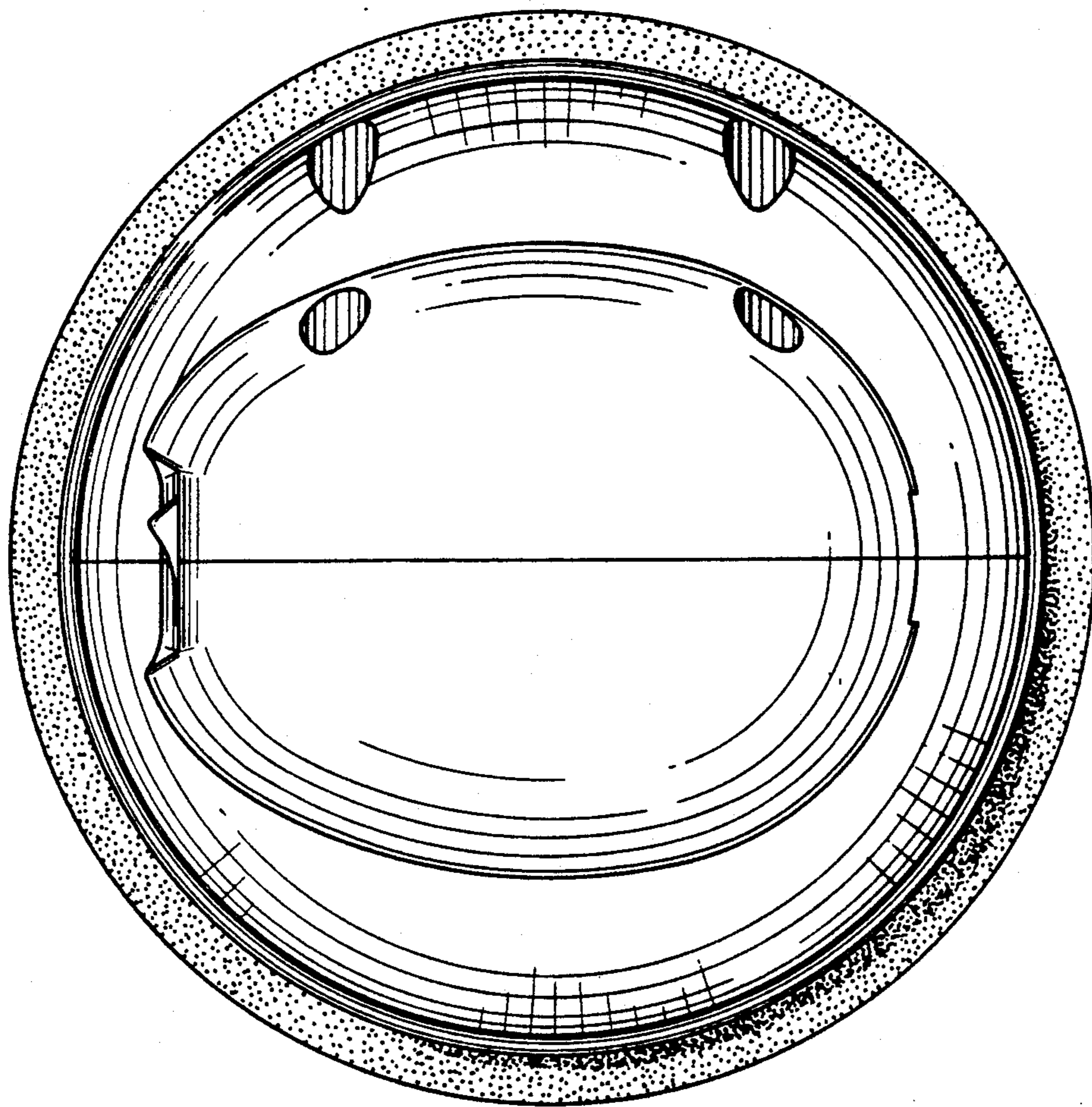

FIG. 6

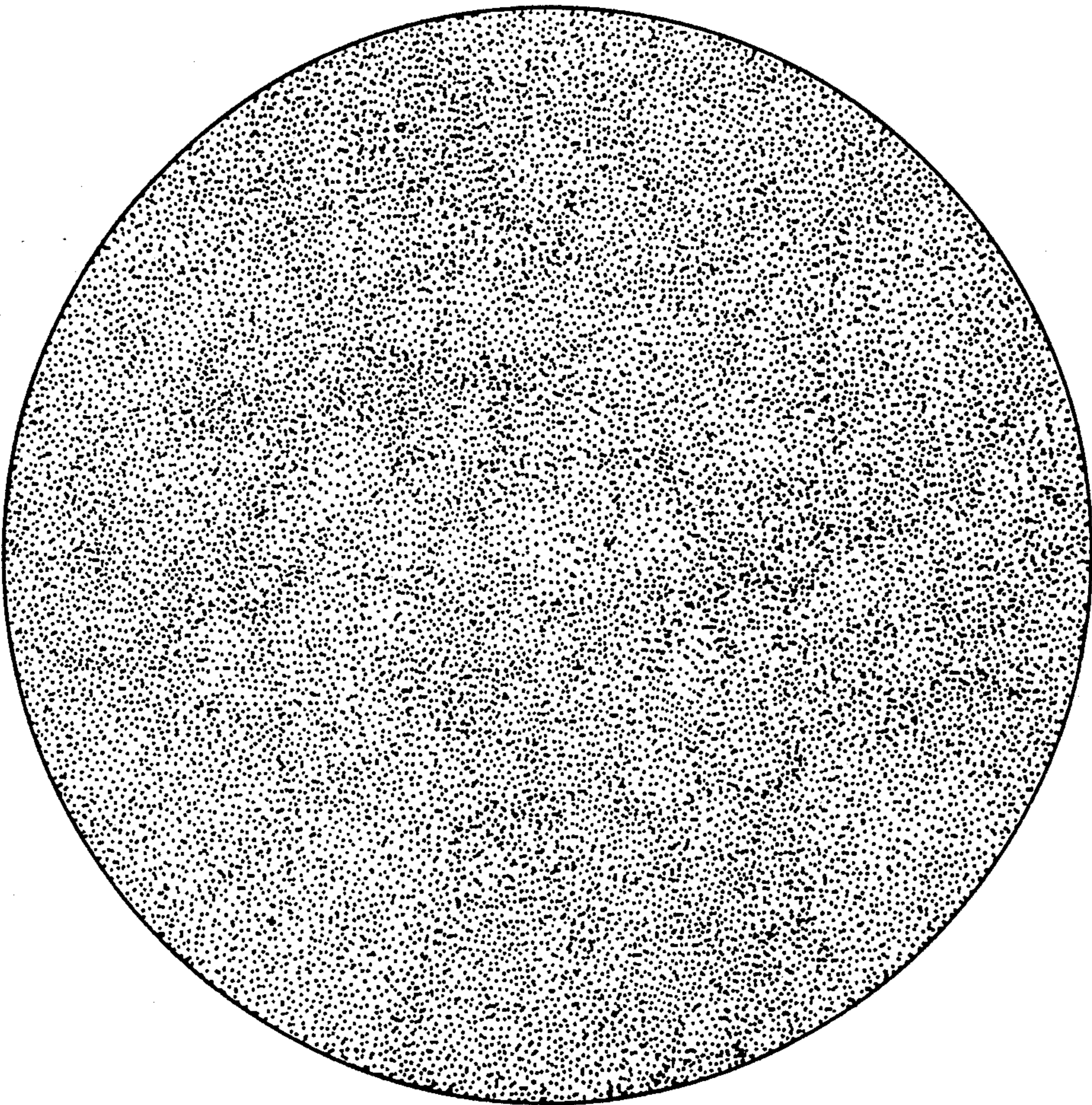

FIG. 7