



US00D332611S

United States Patent [19]

[11] Patent Number: **Des. 332,611**

Tikhonenko

[45] Date of Patent: **** Jan. 19, 1993**

[54] **INTERNAL COMBUSTION ENGINE FOR TECHNICAL MODELS**

D. 125,956	3/1941	May	D15/3
D. 143,449	1/1946	Stewart	D15/3
D. 152,706	2/1949	Leja	D15/1
D. 253,824	1/1980	Hargrave	D15/3

[76] Inventor: **Alexandr A. Tikhonenko, g. Engels**
19, kvartal IV, 2-85, 413119,
Saratovskaya obl., U.S.S.R.

Primary Examiner—A. Hugo Word
Assistant Examiner—R. Seifert
Attorney, Agent, or Firm—Lilling & Lilling

[**] Term: **14 Years**

[57] **CLAIM**

[21] Appl. No.: **620,320**

The ornamental design for an internal combustion engine for technical models, as shown and described.

[22] Filed: **Nov. 29, 1990**

DESCRIPTION

[52] U.S. Cl. **D15/1; D15/3**

[58] Field of Search **D15/1, 3; 244/53 R,**
244/61; 123/179.27, 185 D; D34/15; 35/12 T;
46/78, 249, 39

FIG. 1 is a perspective view of an internal combustion engine showing my new design;
FIG. 2—is a front elevational view thereof;
FIG. 3—is a rear elevational view thereof;
FIG. 4—is a right side elevational view thereof;
FIG. 5—is a left side elevational view thereof;
FIG. 6—is a top plan view thereof;
FIG. 7—is a bottom plan view thereof.

[56] **References Cited**

U.S. PATENT DOCUMENTS

D. 107,641	12/1937	Doil et al.	D15/1
D. 116,981	10/1939	Ohlsson et al.	D15/3

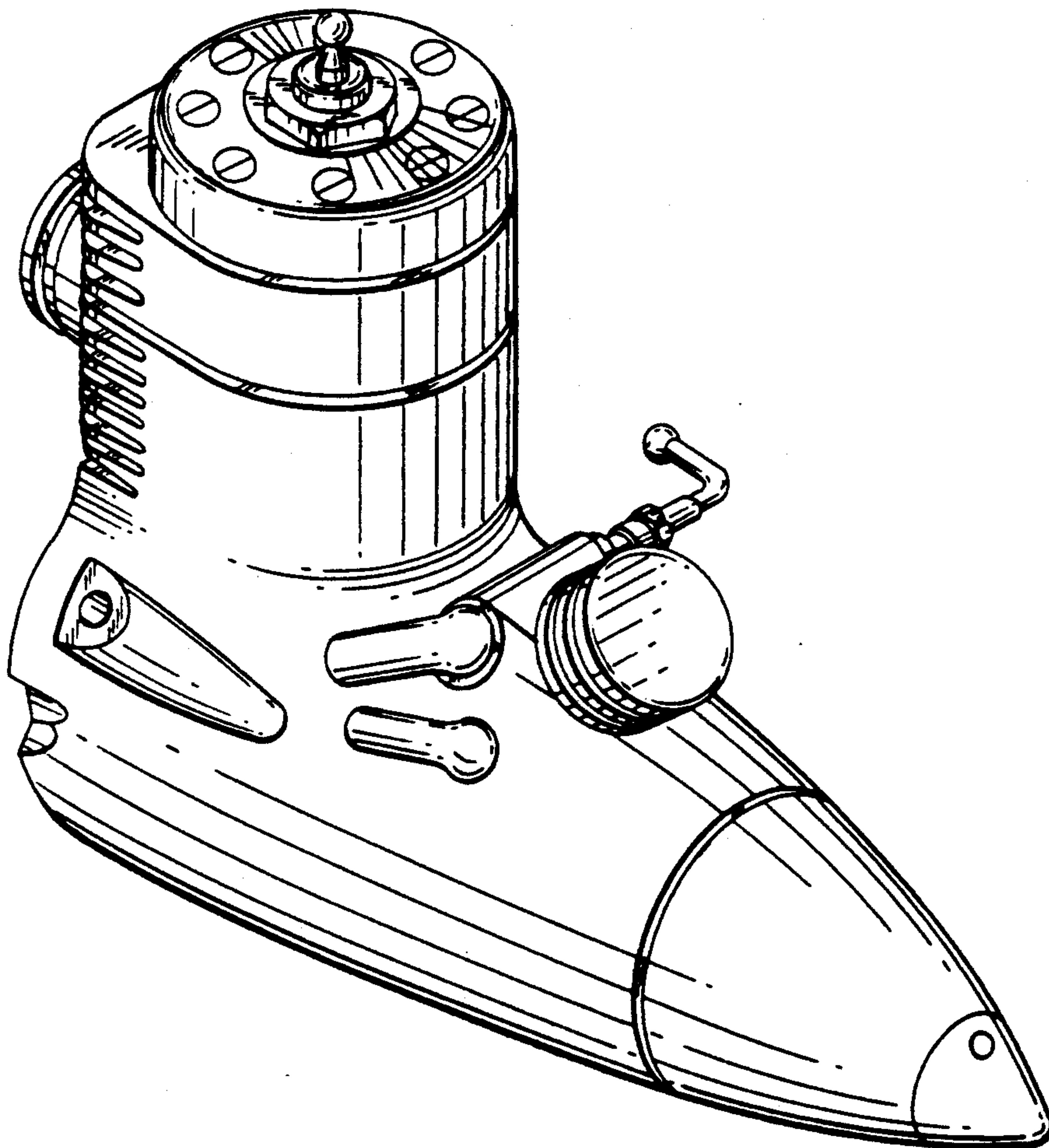

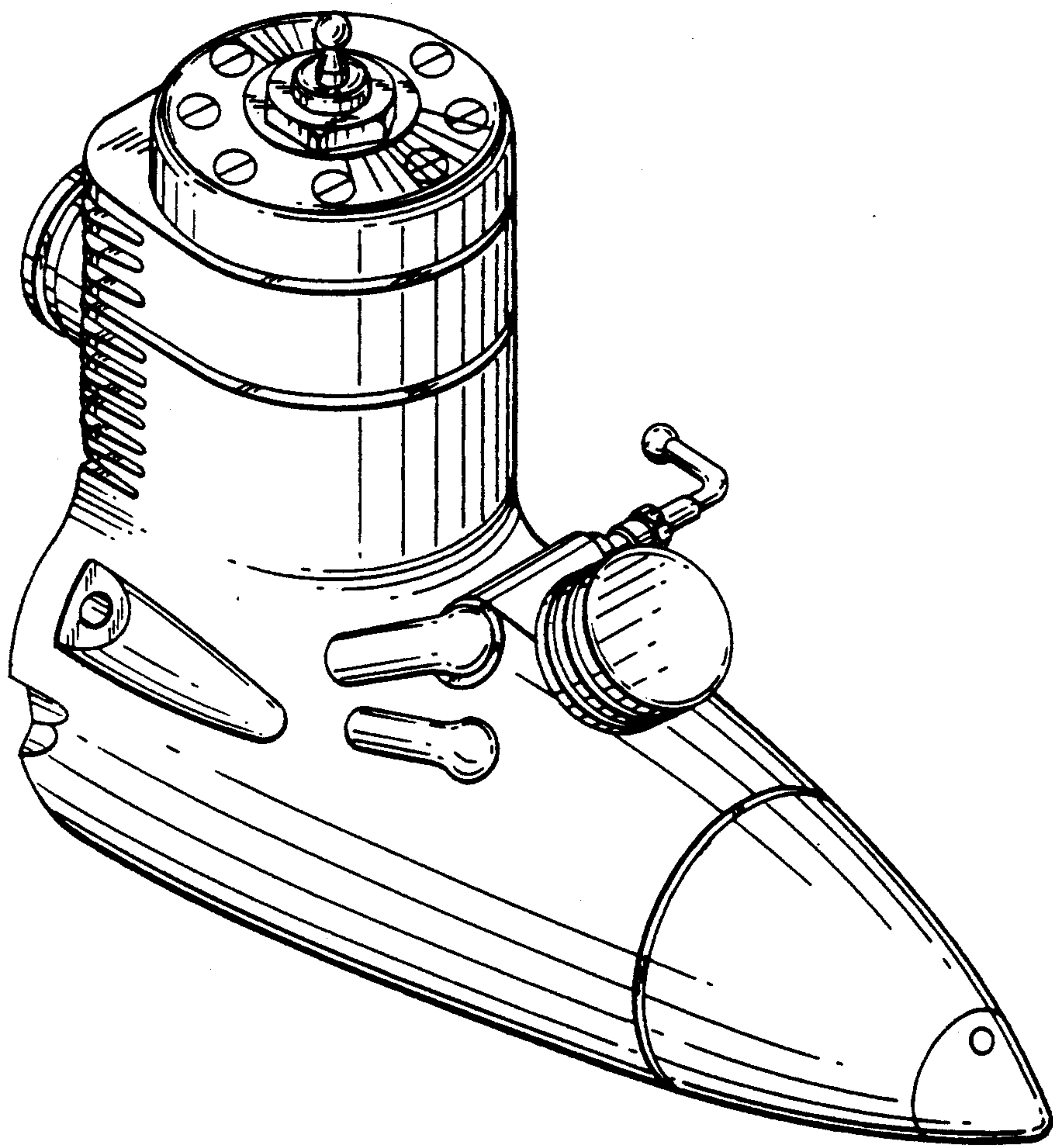

FIG. 1

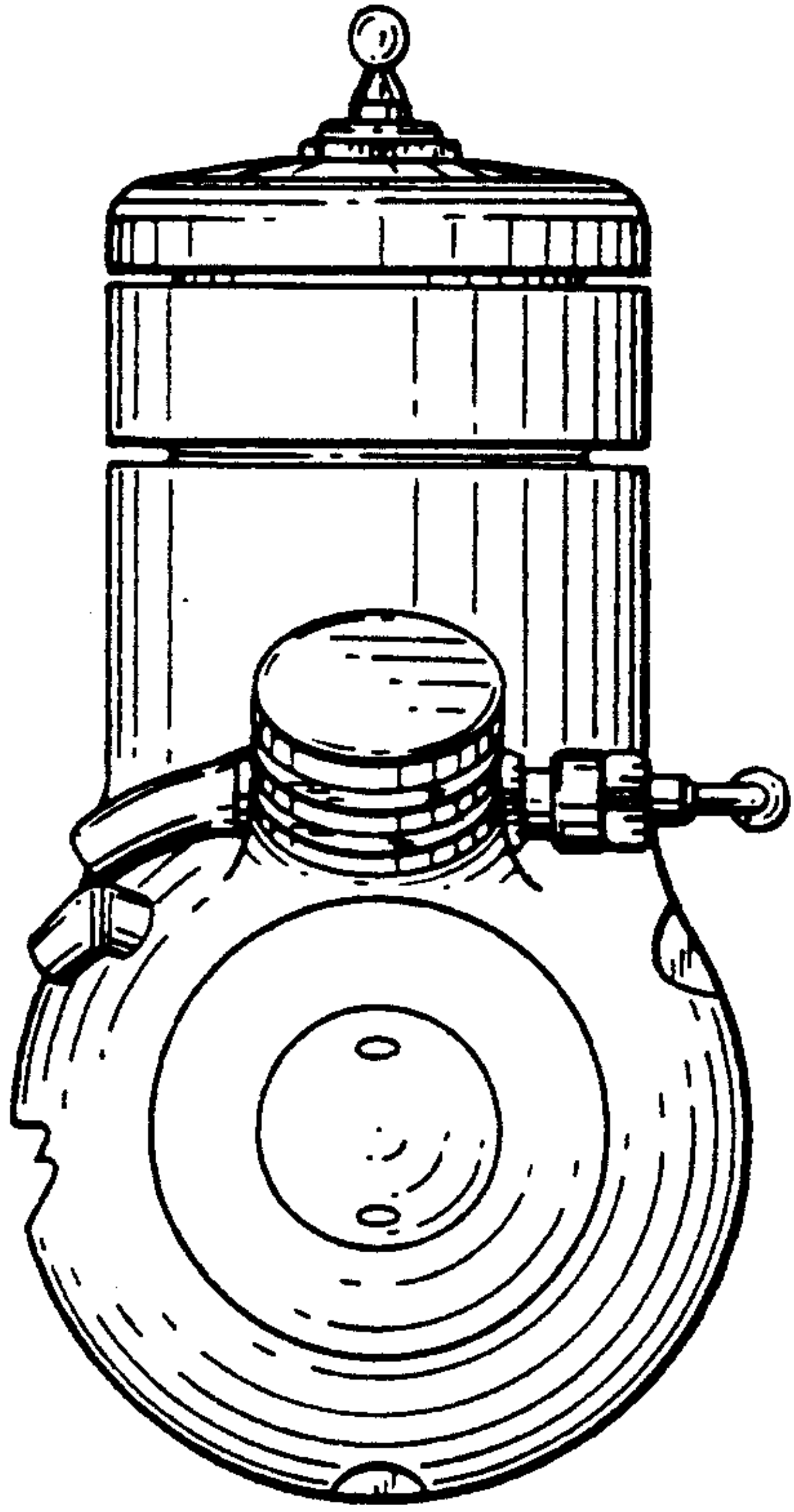

FIG. 2

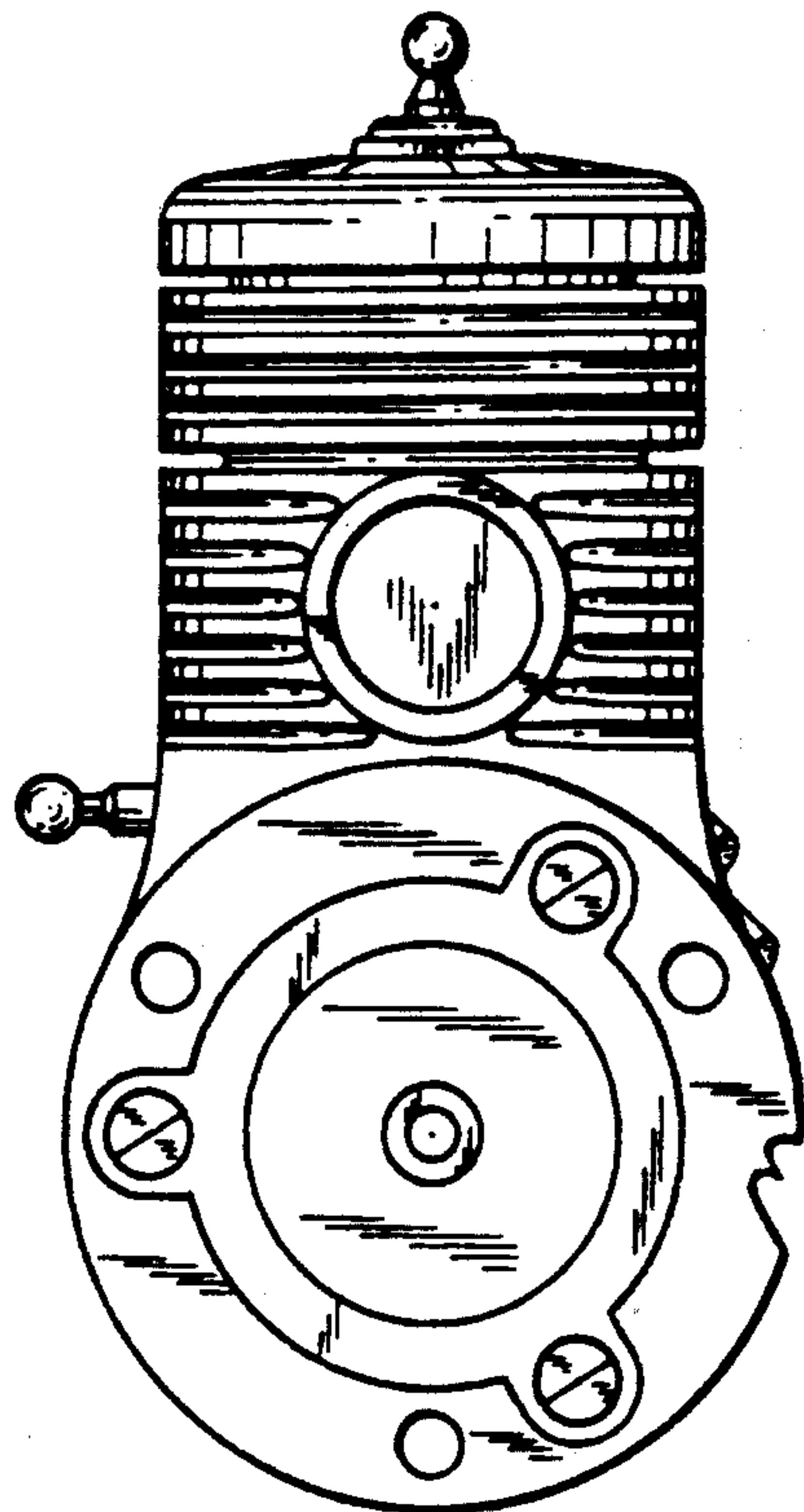

FIG. 3

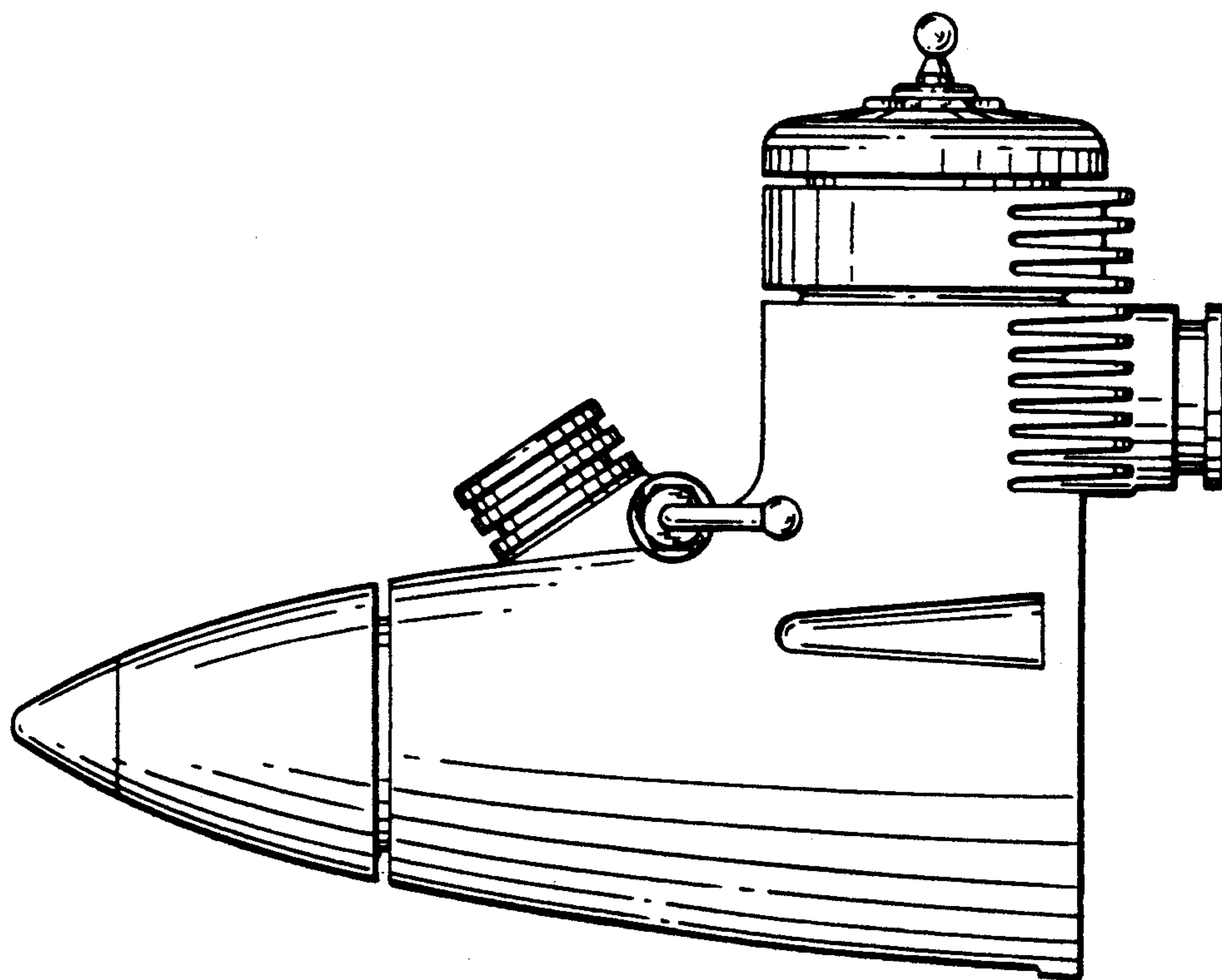
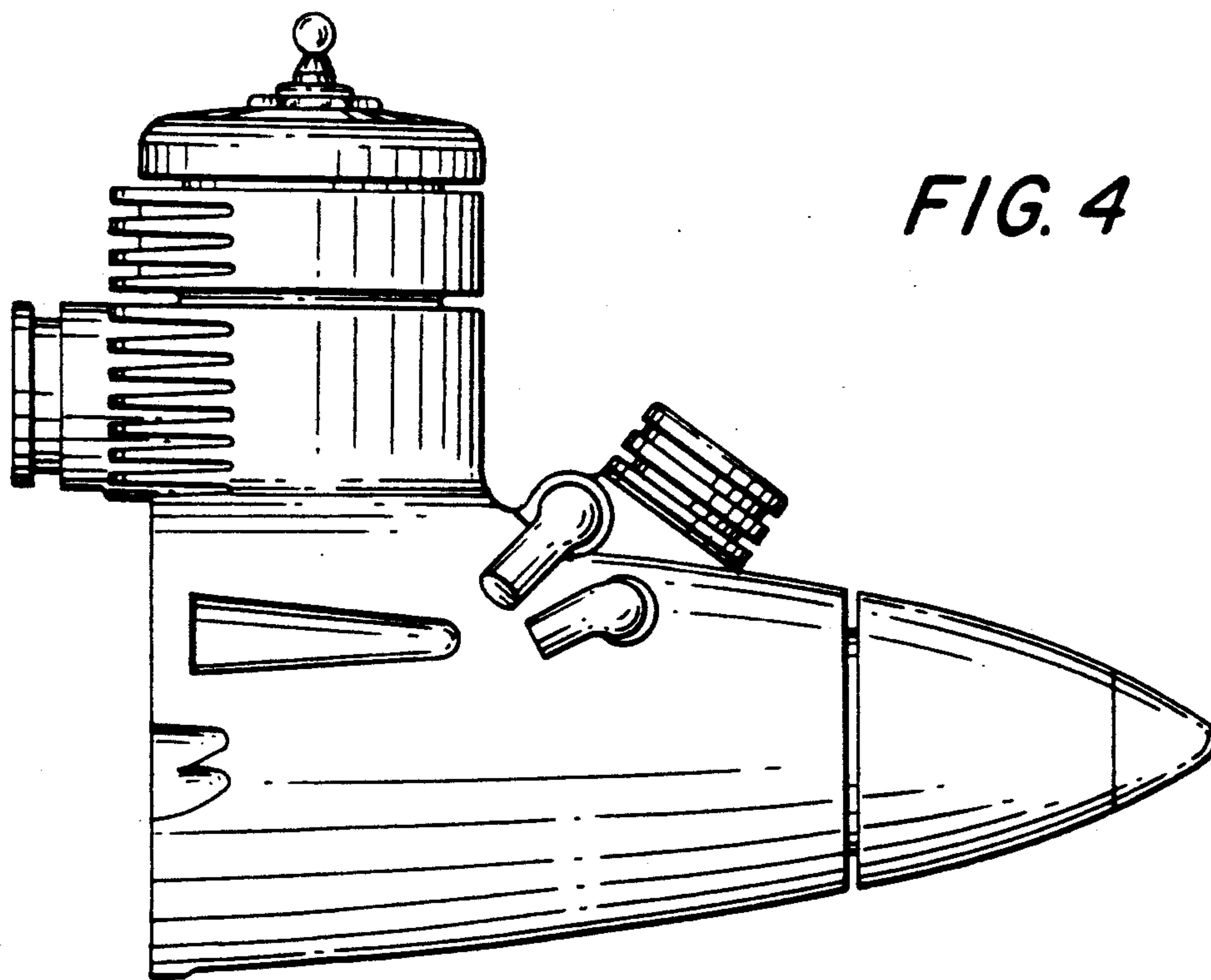

FIG. 5

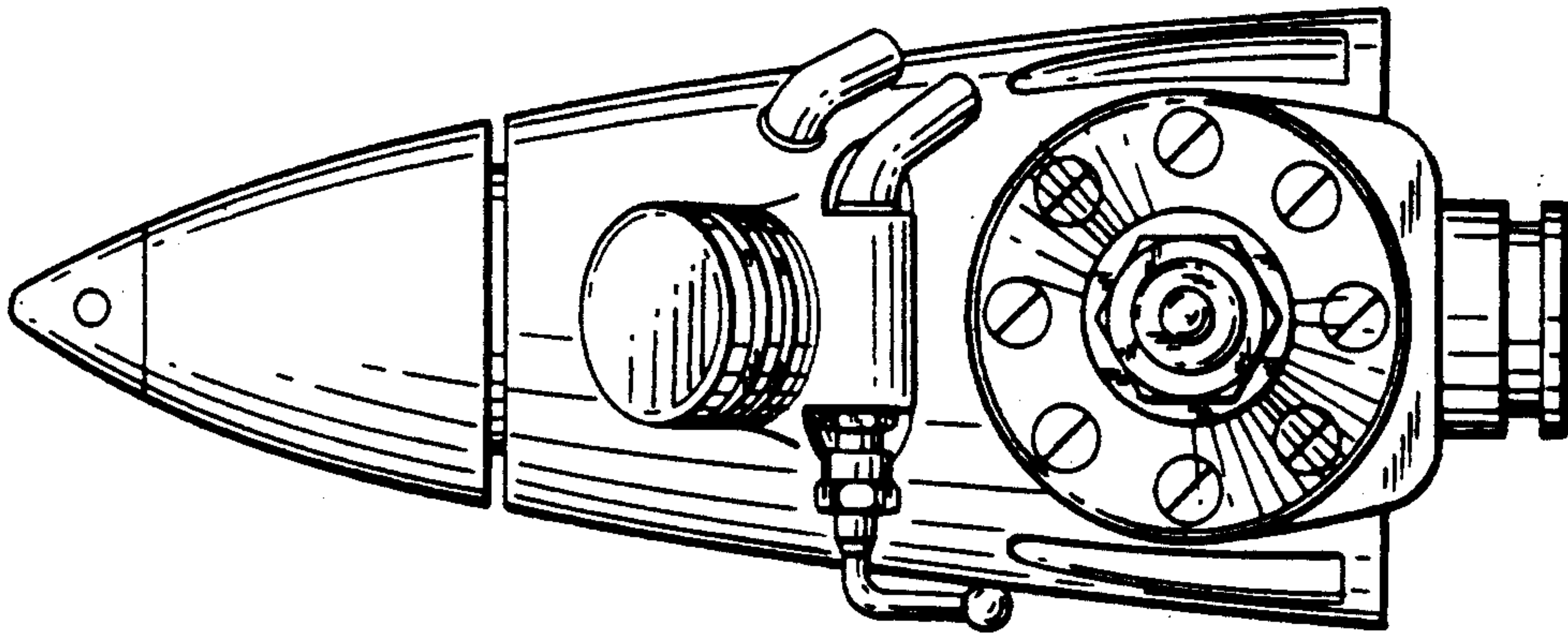

FIG. 6

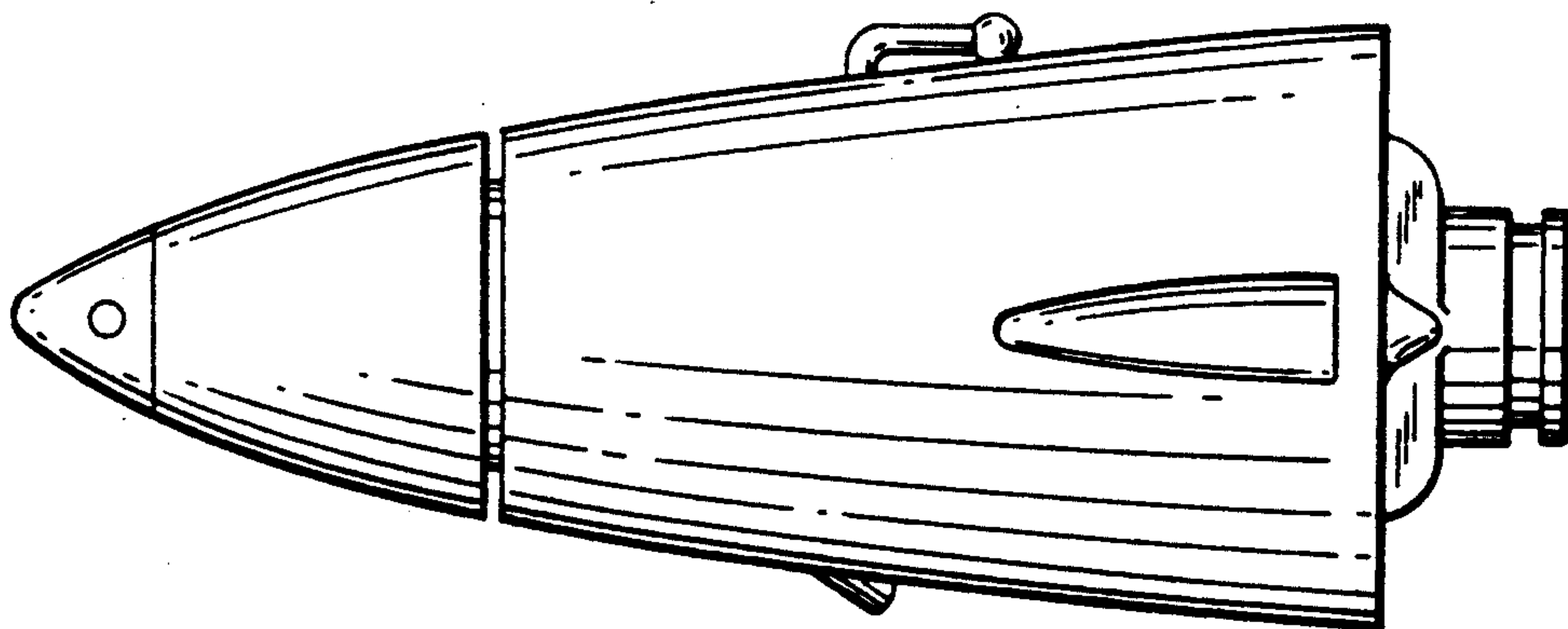

FIG. 7