



US00D332606S

United States Patent [19]

[11] Patent Number: Des. 332,606

Tanizawa et al.

[45] Date of Patent: ** Jan. 19, 1993

[54] FACSIMILE MACHINE

[75] Inventors: **Akiyoshi Tanizawa**, Osaka; **Yuji Abe**, Yamatotakada, both of Japan

[73] Assignee: **Mita Industrial Co., Ltd.**, Osaka, Japan

[**] Term: **14 Years**

[21] Appl. No.: **638,510**

[22] Filed: **Jan. 9, 1991**

[30] Foreign Application Priority Data

Jul. 9, 1990 [JP] Japan 2-23312

[52] U.S. Cl. **D14/118**

[58] Field of Search **D14/118, 124, 299; D18/36, 37; 358/400, 401**

[56] References Cited

U.S. PATENT DOCUMENTS

- D. 289,048 3/1987 Kojima D14/118
- D. 314,569 2/1991 Tsuruoka D14/118
- D. 314,931 2/1991 Takayama et al. D14/118
- D. 323,159 1/1992 Isasaki et al. D14/118
- D. 323,161 1/1992 Hiroki et al. D14/118

OTHER PUBLICATIONS

Today's Office, Nov. 1986, p. 69, Top right—Digital fax transceiver.

Primary Examiner—Theodore M. Shooman

Attorney, Agent, or Firm—Spencer, Frank & Schneider

[57] CLAIM

The ornamental design for a facsimile machine, as shown and described.

DESCRIPTION

FIG. 1 is a top plan view of a facsimile machine showing our new design;

FIG. 2 is a front elevational view thereof;

FIG. 3 is a right side elevational view thereof;

FIG. 4 is a left side elevational view thereof;

FIG. 5 is a bottom plan view thereof;

FIG. 6 is a rear elevational view thereof;

FIG. 7 is a top, front and right side perspective view thereof;

FIG. 8 is a top plan view of a second embodiment of the facsimile machine shown in FIG. 1;

FIG. 9 is a front elevational view of the embodiment disclosed in FIG. 8;

FIG. 10 is a right side elevational view of the embodiment disclosed in FIG. 8;

FIG. 11 is a left side elevational view of the embodiment disclosed in FIG. 8;

FIG. 12 is a bottom plan view of the embodiment disclosed in FIG. 8;

FIG. 13 is a rear elevational view of the embodiment disclosed in FIG. 8; and,

FIG. 14 is a top, front and right side perspective view of the embodiment disclosed in FIG. 8.

The broken line showing of the paper guides in FIGS. 7 and 14 is for illustrative purposes only and forms no part of the claimed design.

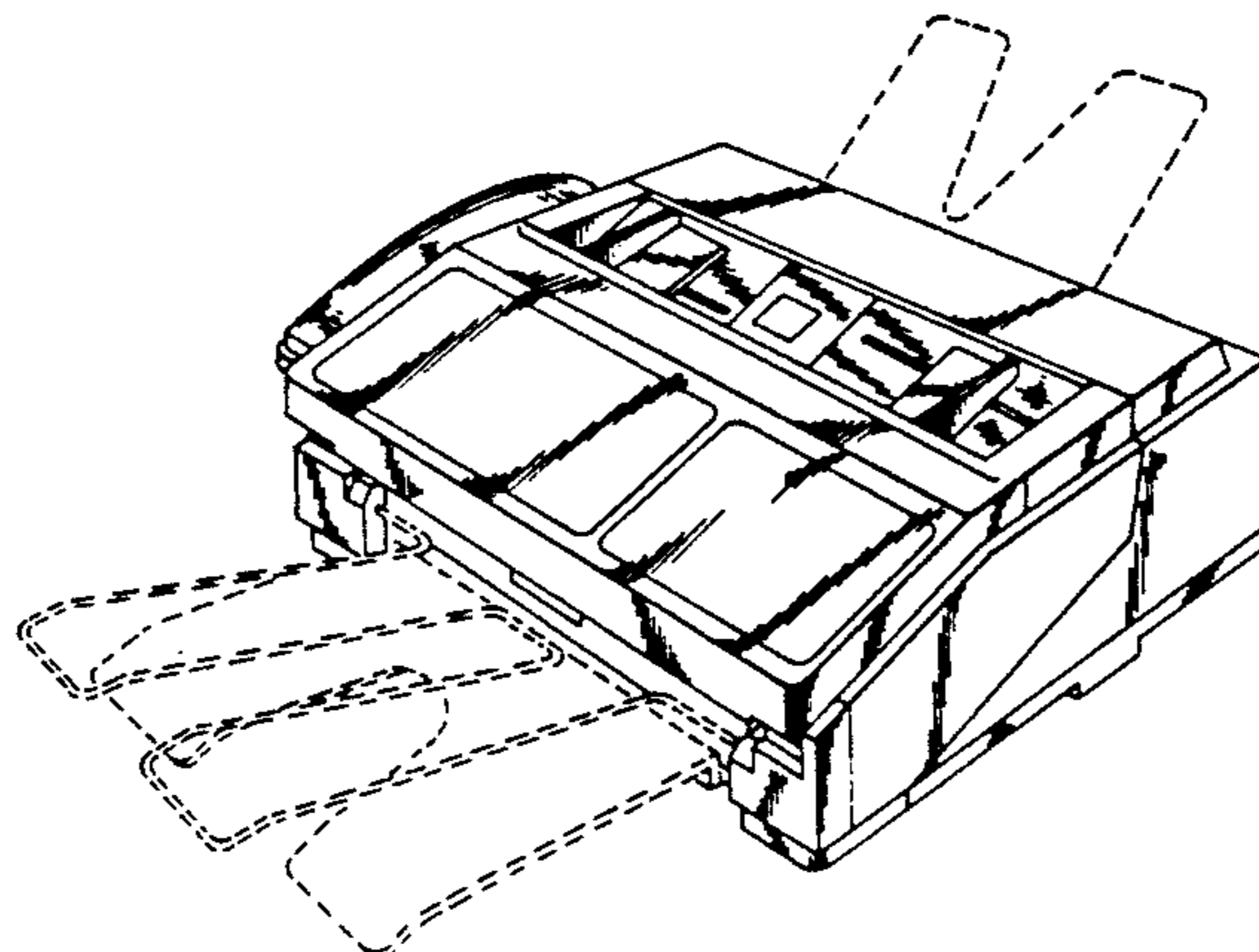
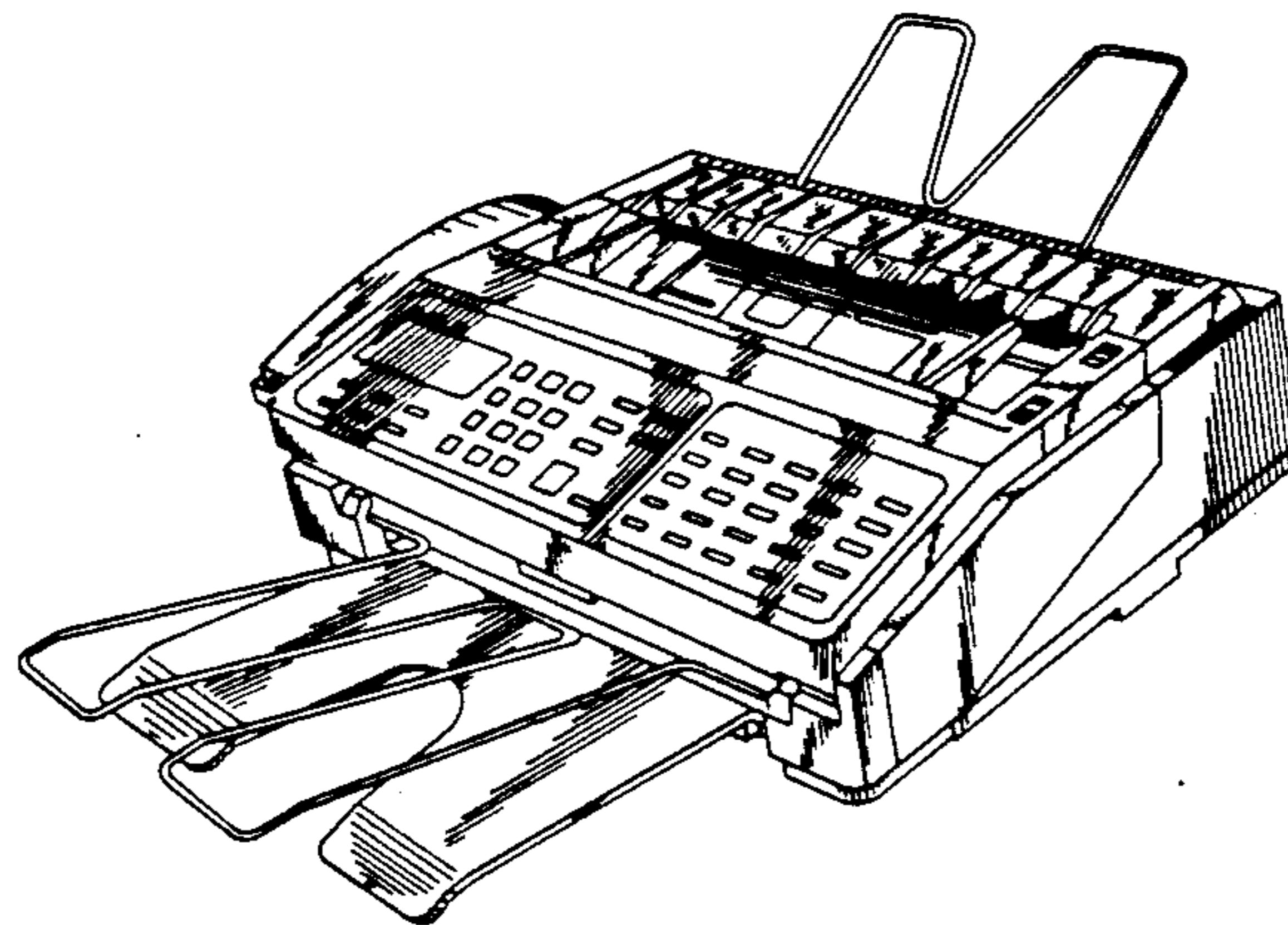

FIG. 1

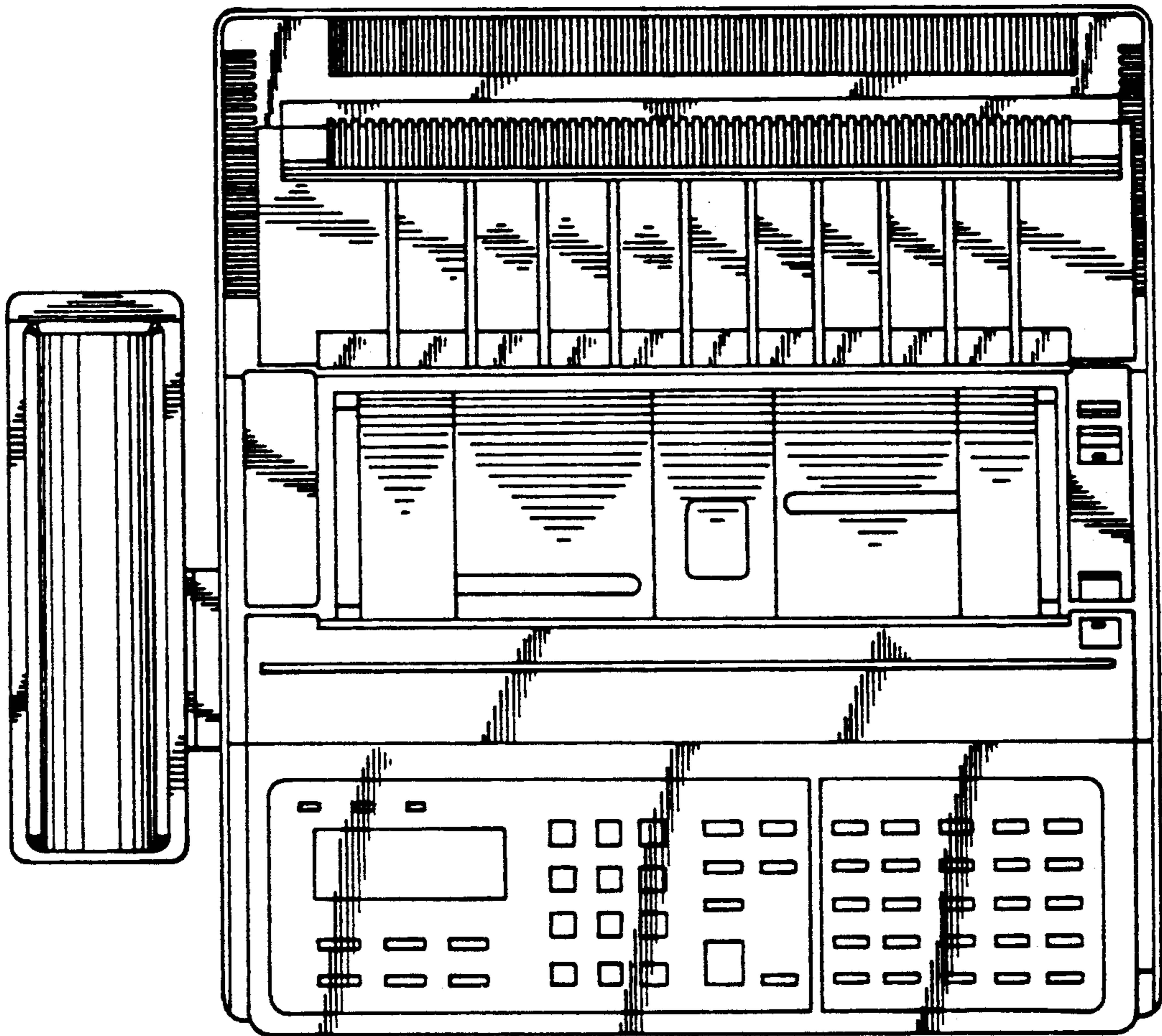

FIG. 2

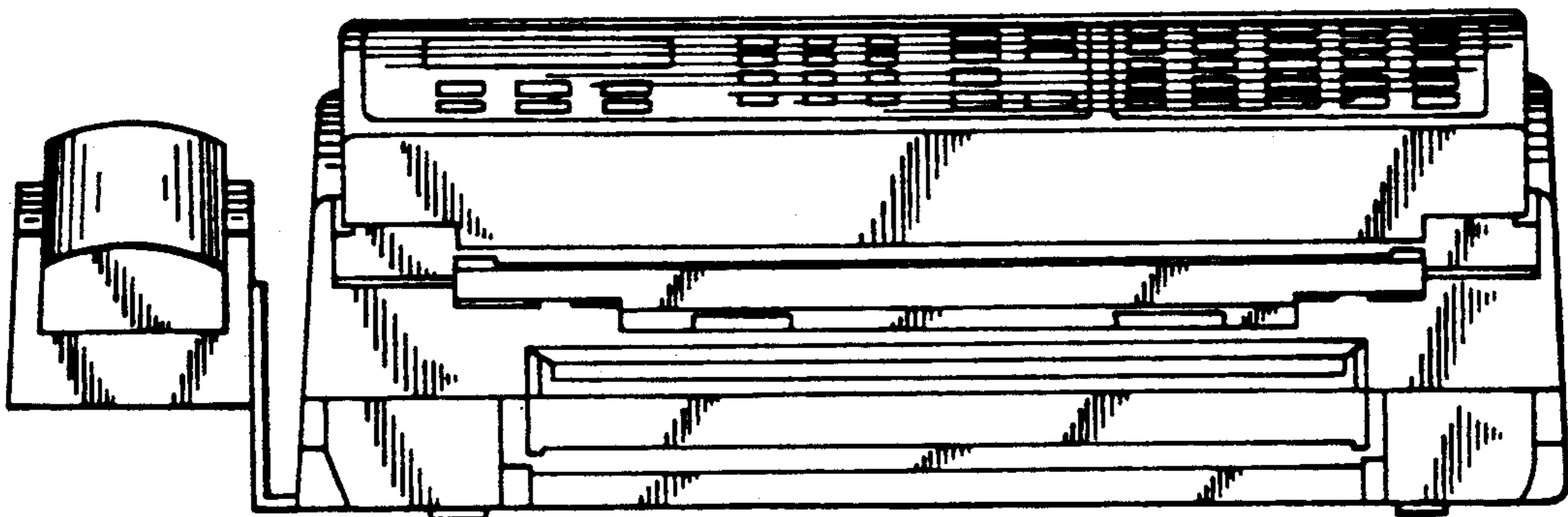

FIG. 3

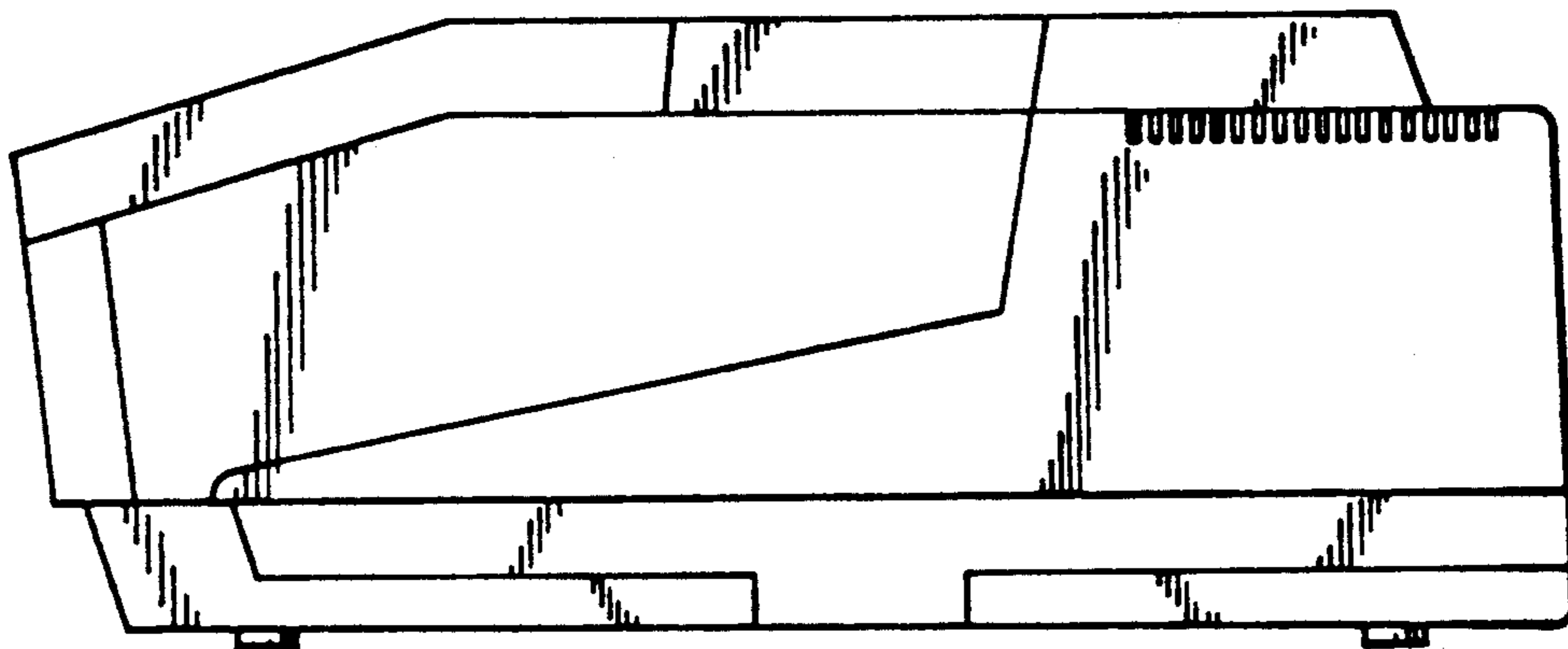

FIG. 4

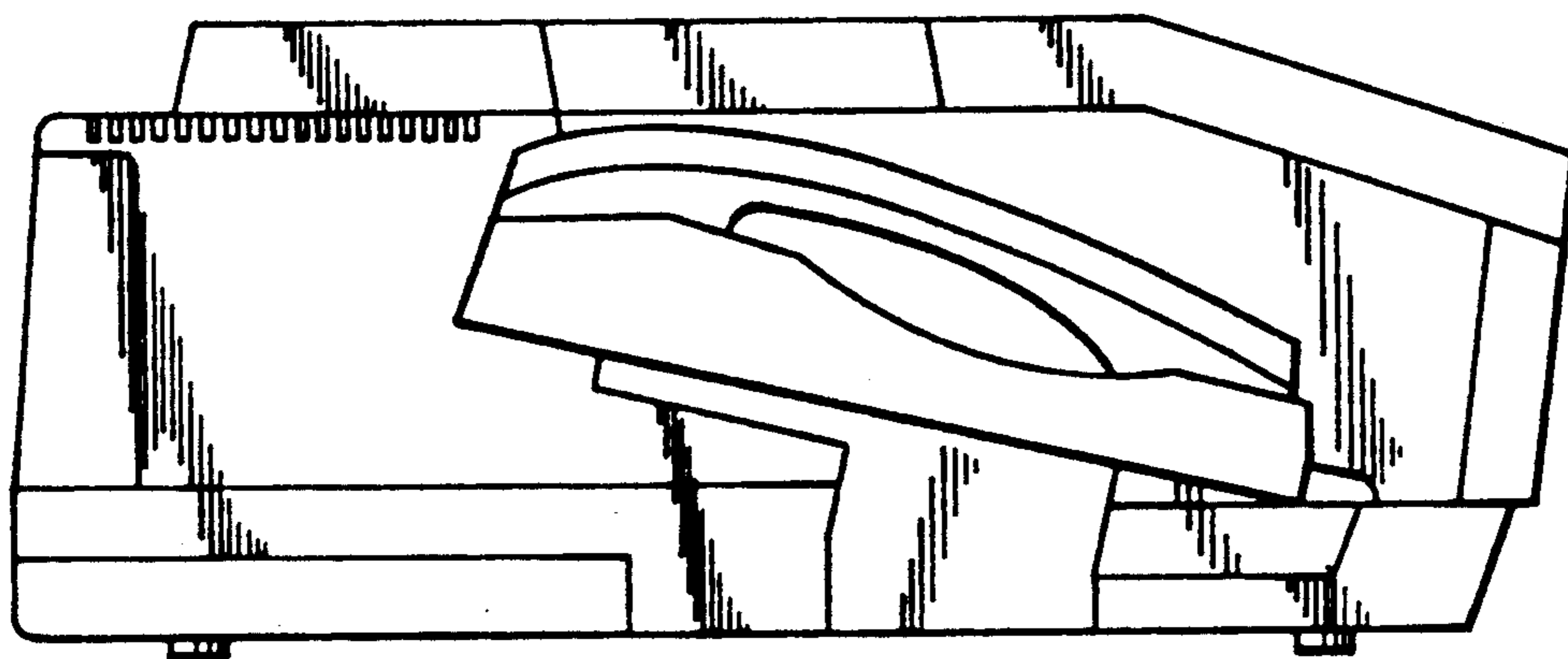

FIG. 5

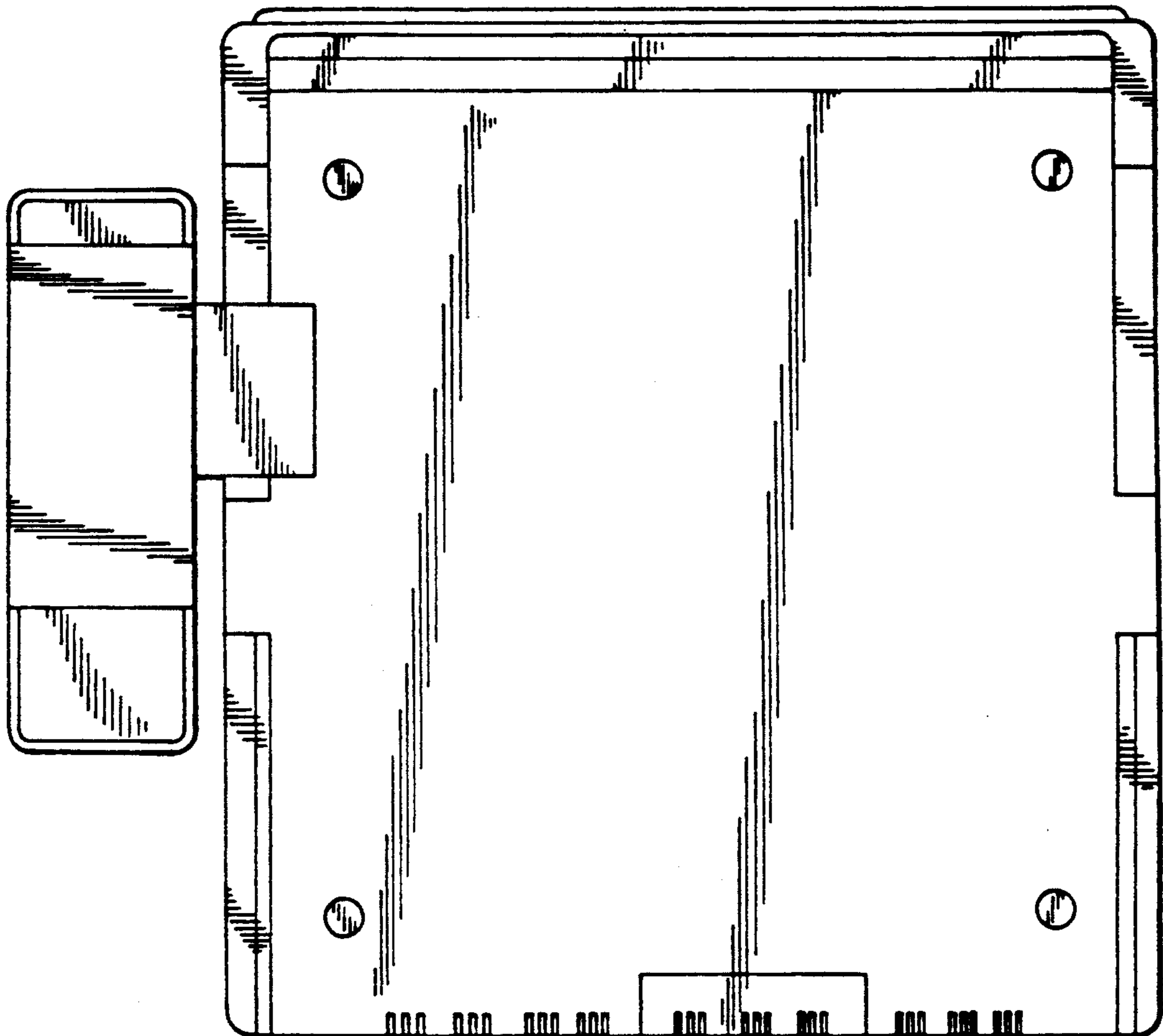
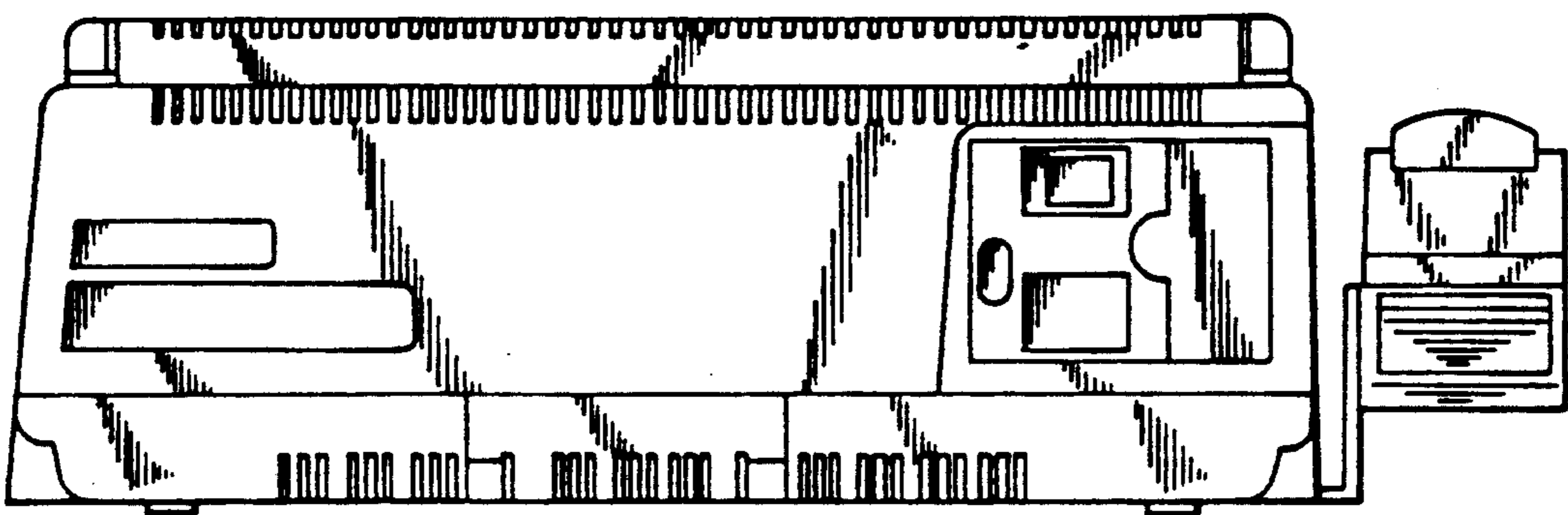

FIG. 6



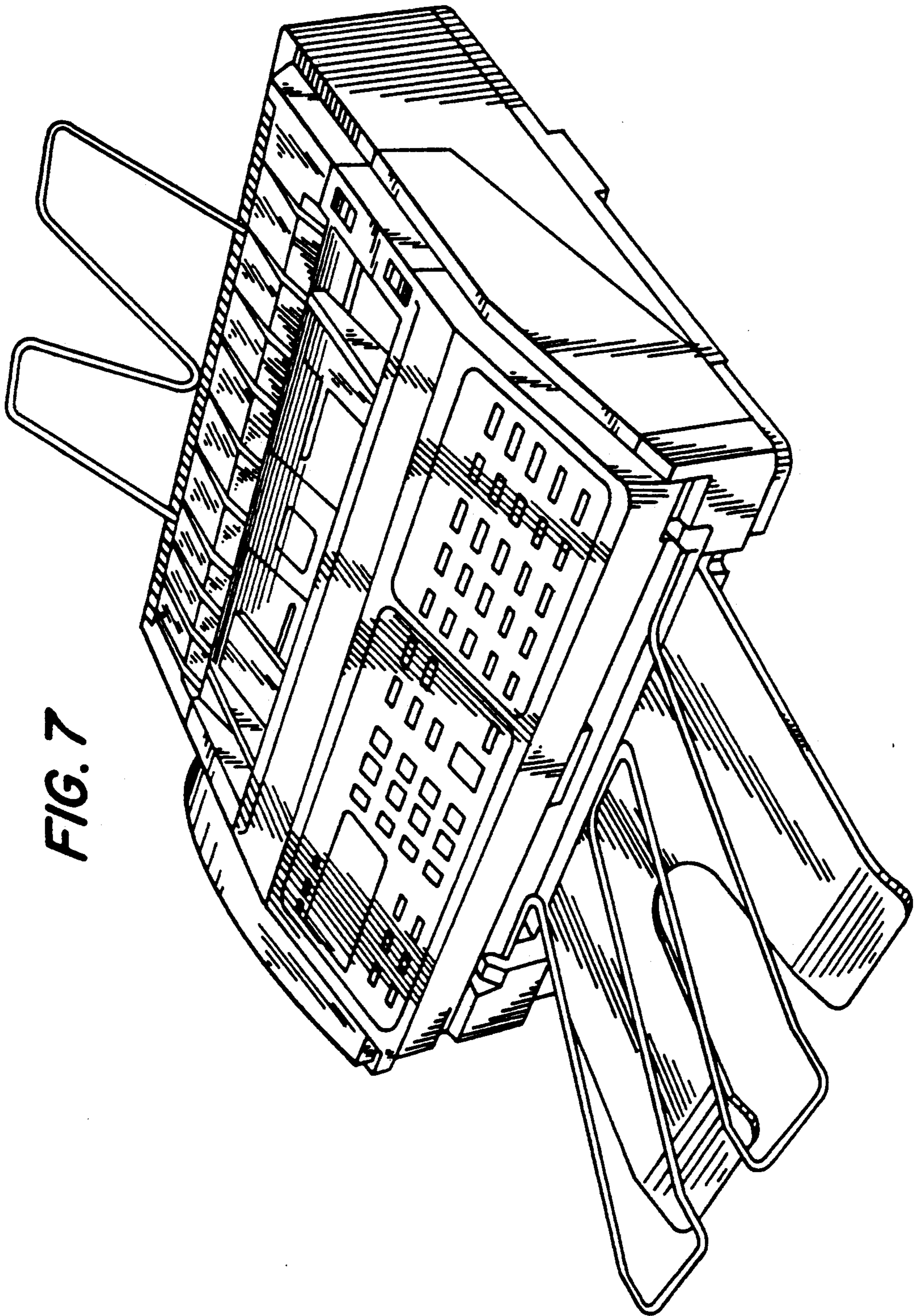

FIG. 7

FIG. 8

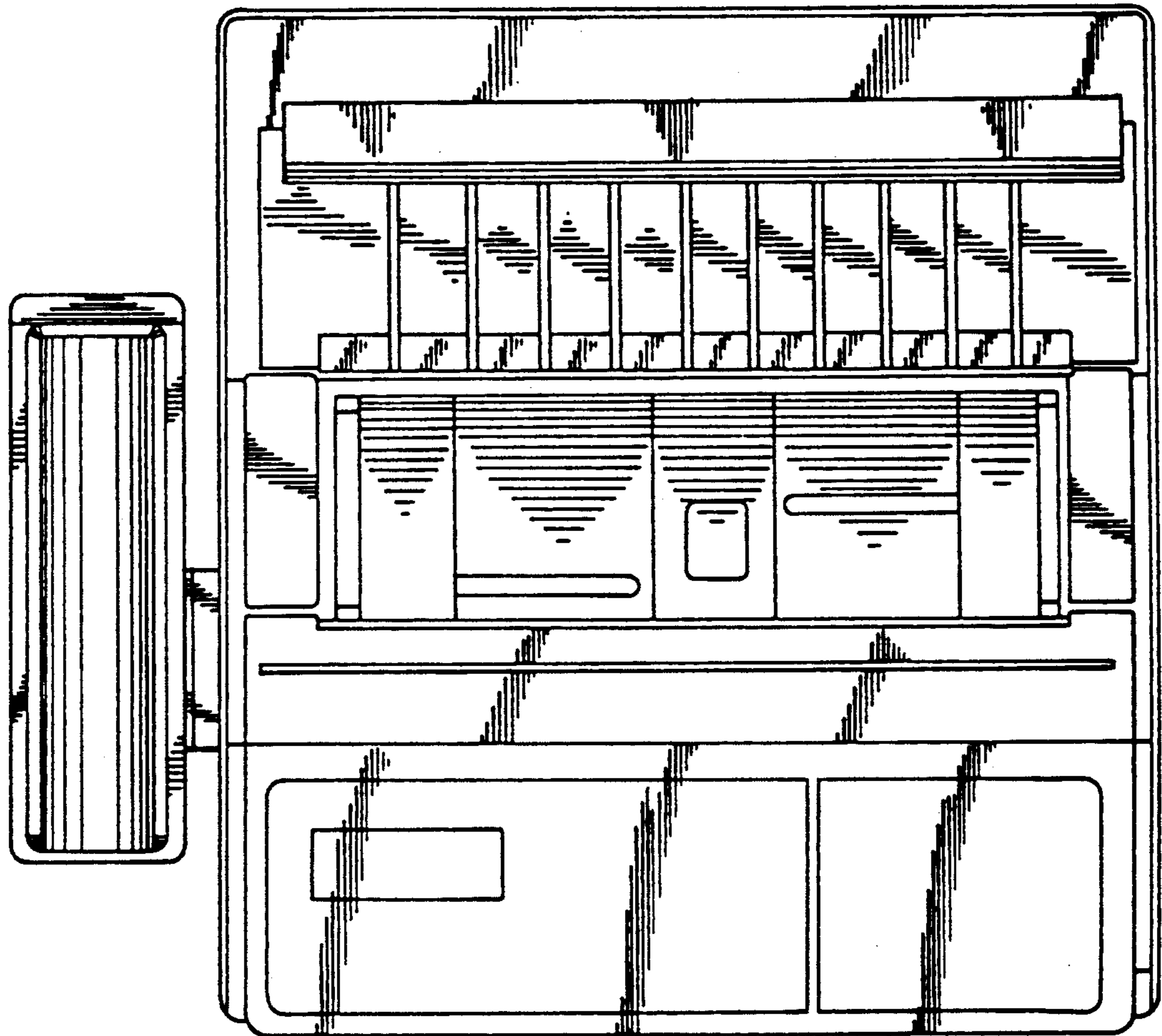

FIG. 9

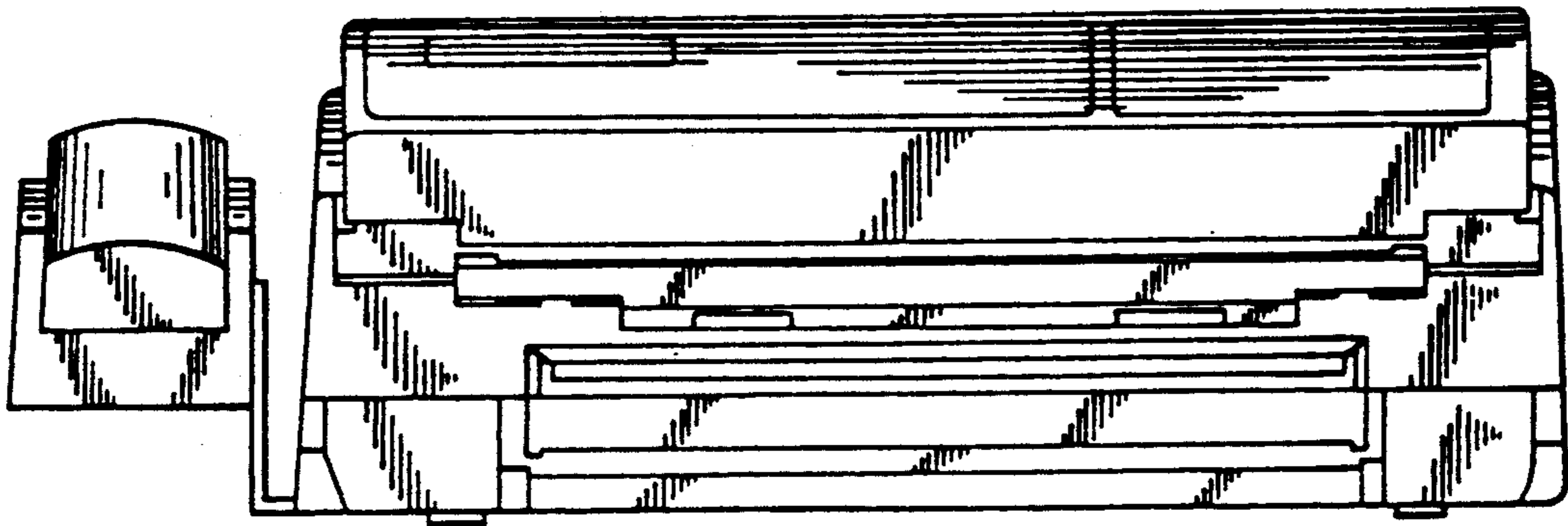

FIG. 10

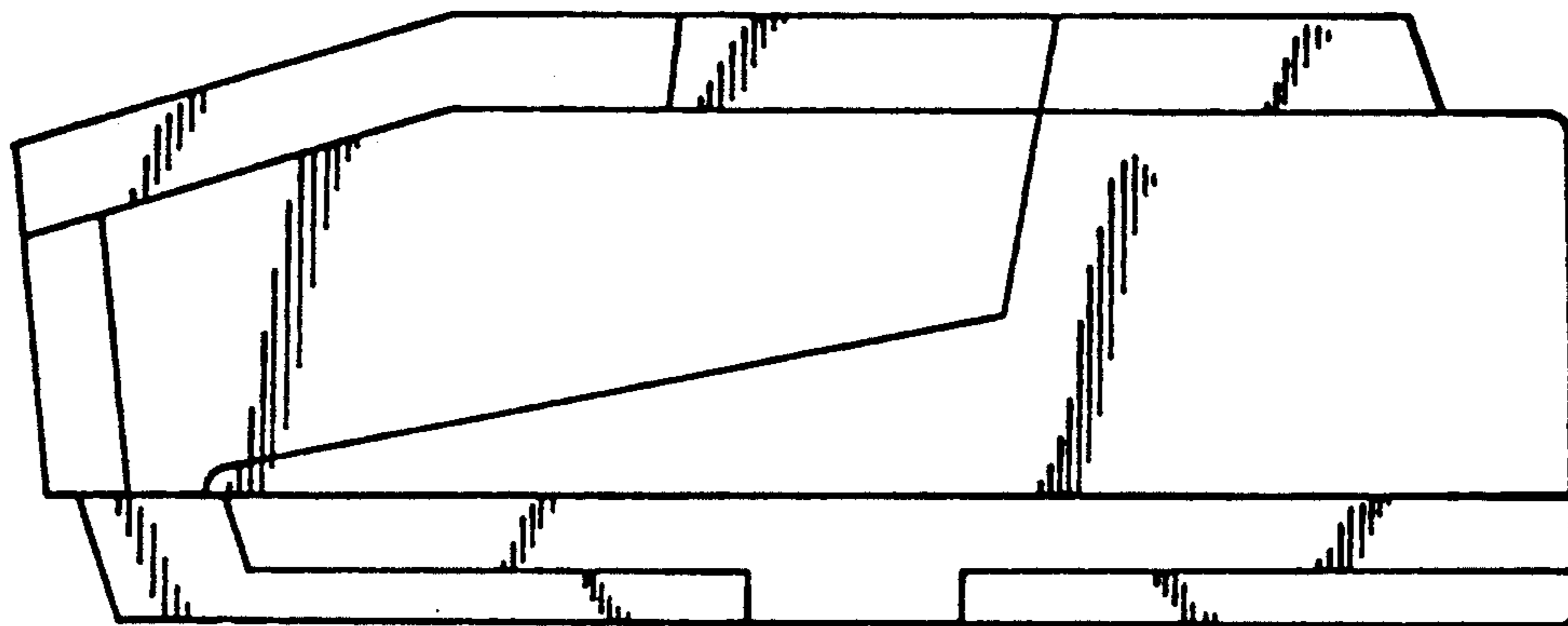

FIG. 11

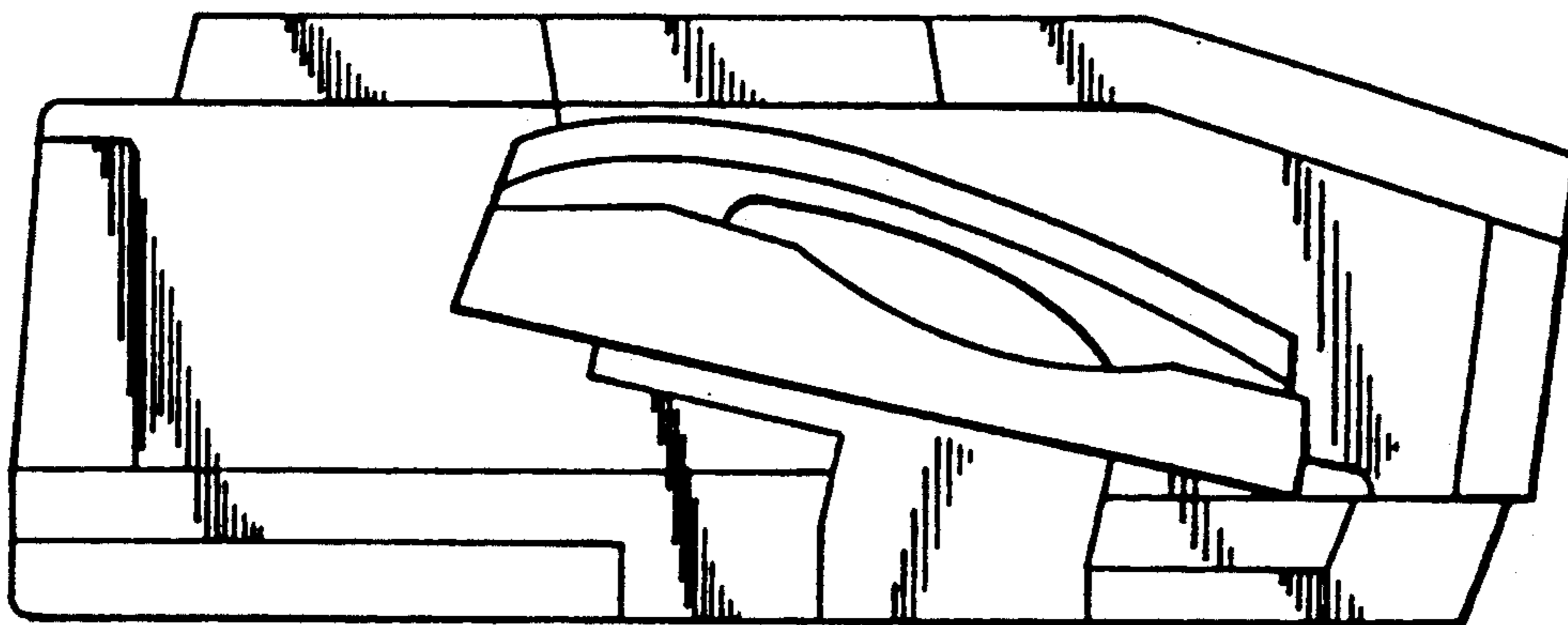

FIG. 12

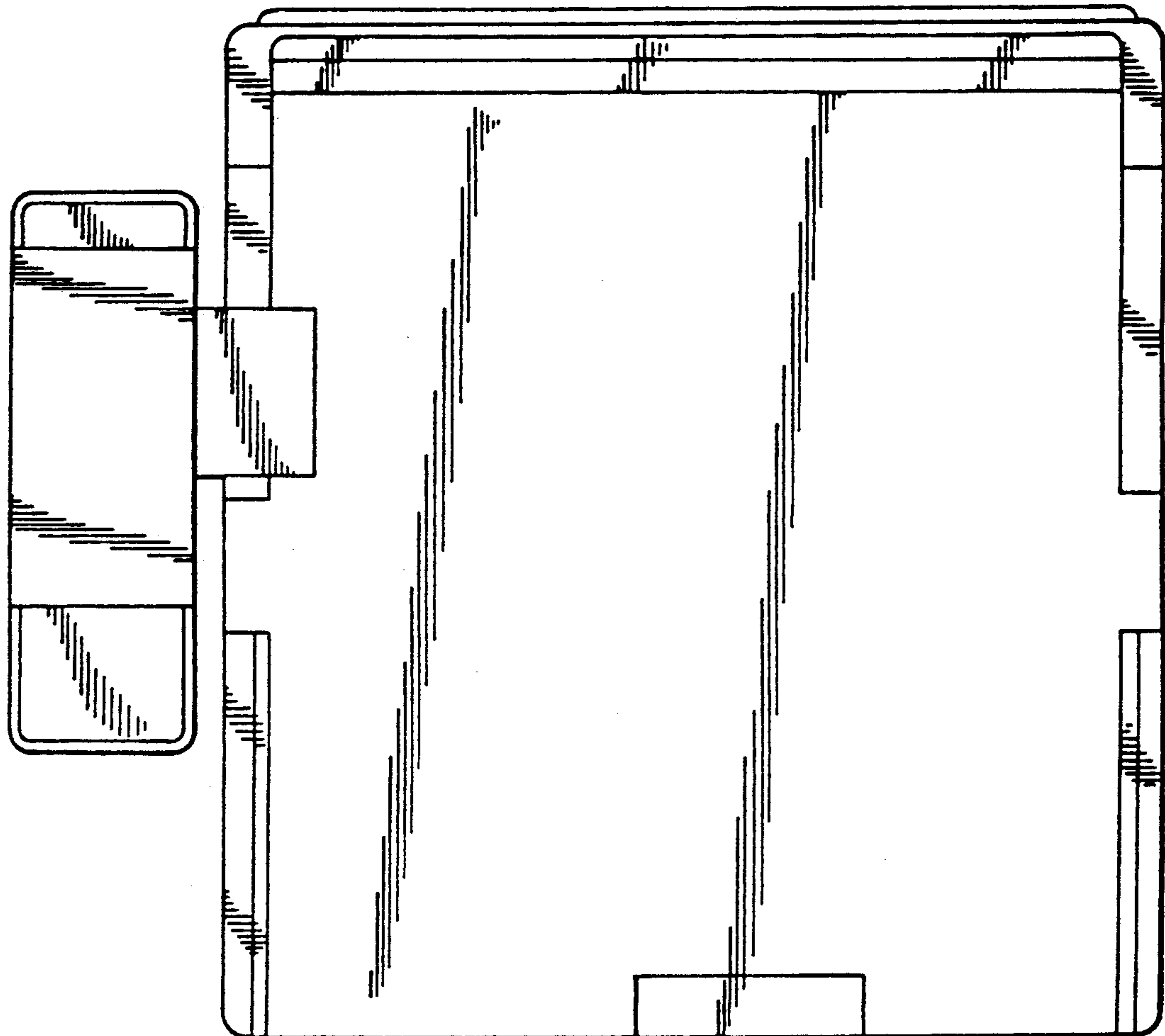

FIG. 13

