



US00D332485S

United States Patent [19]

[11] Patent Number: Des. 332,485

Shaw

[45] Date of Patent: ** Jan. 12, 1993

[54] SENSOR FOR CONTROLLING THE WATER SUPPLY OF LAVATORY FIXTURES

[75] Inventor: Daniel C. Shaw, Geneva, Fla.

[73] Assignee: Bauer Industries, Inc., Orlando, Fla.

[**] Term: 14 Years

[21] Appl. No.: 216,446

[22] Filed: Jul. 8, 1988

[52] U.S. Cl. D23/303; D23/303

[58] Field of Search D23/238, 303, 308; D10/104; D34/11; D17/22; 340/556, 555; 250/221

[56] References Cited

U.S. PATENT DOCUMENTS

D. 276,753	12/1984	Maza et al.	D34/11
D. 280,857	10/1985	Fuller et al.	D34/11
1,929,273	10/1933	Crago	250/221
1,985,563	12/1934	Fitzgerald	250/221
3,419,188	12/1968	Matchett	250/221
3,576,277	4/1971	Blackmon	250/221
4,767,922	8/1988	Stauffer	340/556
4,910,498	3/1990	Feher	340/556

OTHER PUBLICATIONS

Water-Matic Double Solenoid Command 80 System Brochure, published prior to Jul. 1988.

Primary Examiner—James M. Gandy

Attorney, Agent, or Firm—Joseph W. Berenato, III

[57] CLAIM

The ornamental design for a sensor for controlling the water supply of lavatory fixtures, as shown and described.

DESCRIPTION

FIG. 1 is a top perspective view of a first embodiment of a sensor for controlling the water supply of lavatory fixtures according to my new design;

FIG. 2 is a bottom perspective view thereof;

FIG. 3 is a front elevational view thereof;

FIG. 4 is a left side elevational view thereof;

FIG. 5 is a top perspective view of a second embodiment of a sensor for controlling the water supply of lavatory fixtures showing my new design;

FIG. 6 is a bottom perspective view of FIG. 5;

FIG. 7 is a front elevational view of FIG. 5;

FIG. 8 is a left side elevational view of FIG. 5;

FIG. 9 is a top perspective view of a third embodiment of a sensor for controlling the water supply of lavatory fixtures showing my new design;

FIG. 10 is a bottom perspective view of FIG. 9;

FIG. 11 is a front elevational view of FIG. 9;

FIG. 12 is a left side elevational view of FIG. 9;

FIG. 13 is a top perspective view of a fourth embodiment of a sensor for controlling the water supply of lavatory fixtures showing my new design;

FIG. 14 is a bottom perspective view of FIG. 13;

FIG. 15 is a front elevational view of FIG. 13; and,

FIG. 16 is a left side elevational view of FIG. 13.

The right side elevational views pursuant to FIGS. 4, 8, 12 and 16 are mirror images thereof.

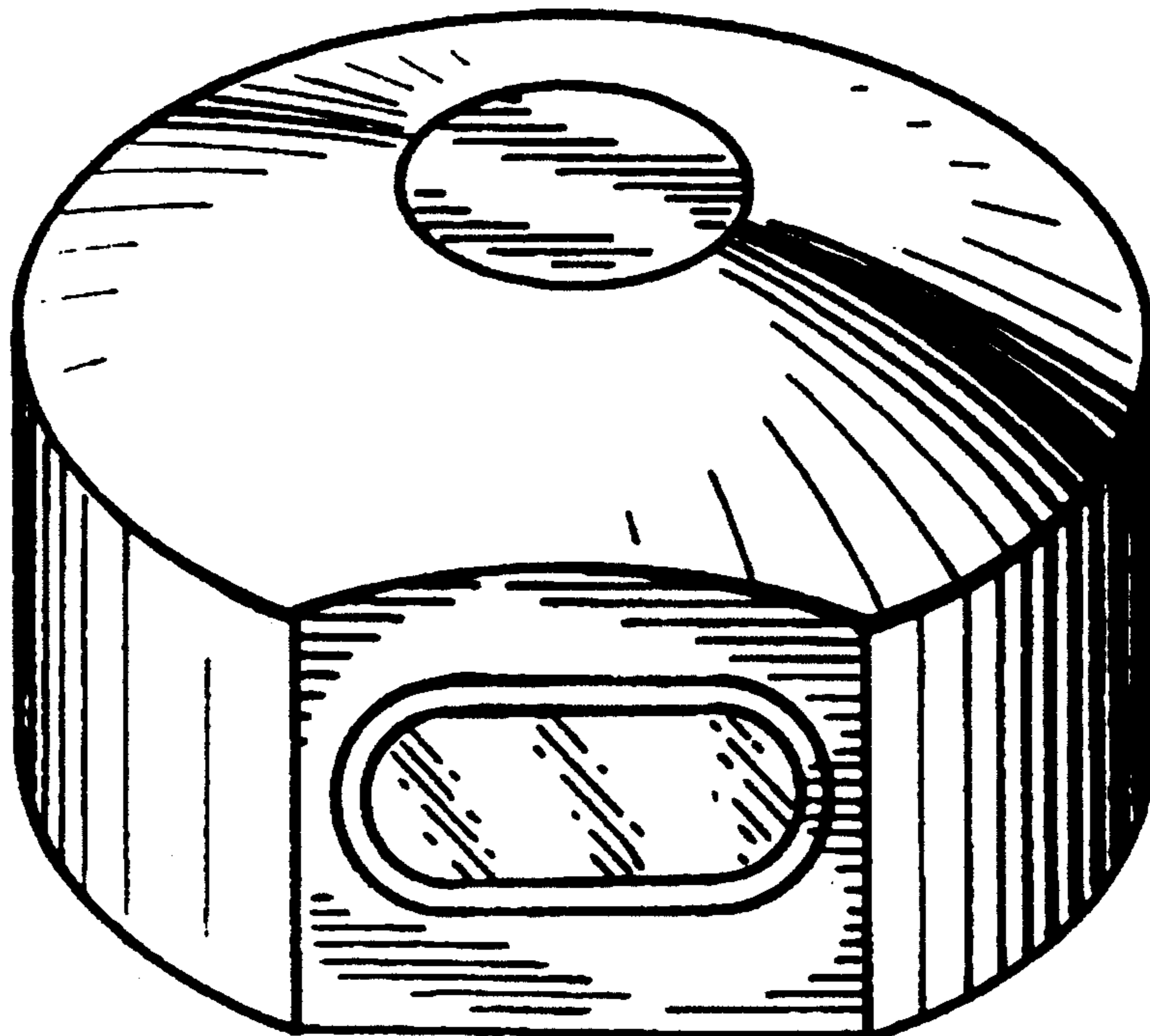

FIG. 1

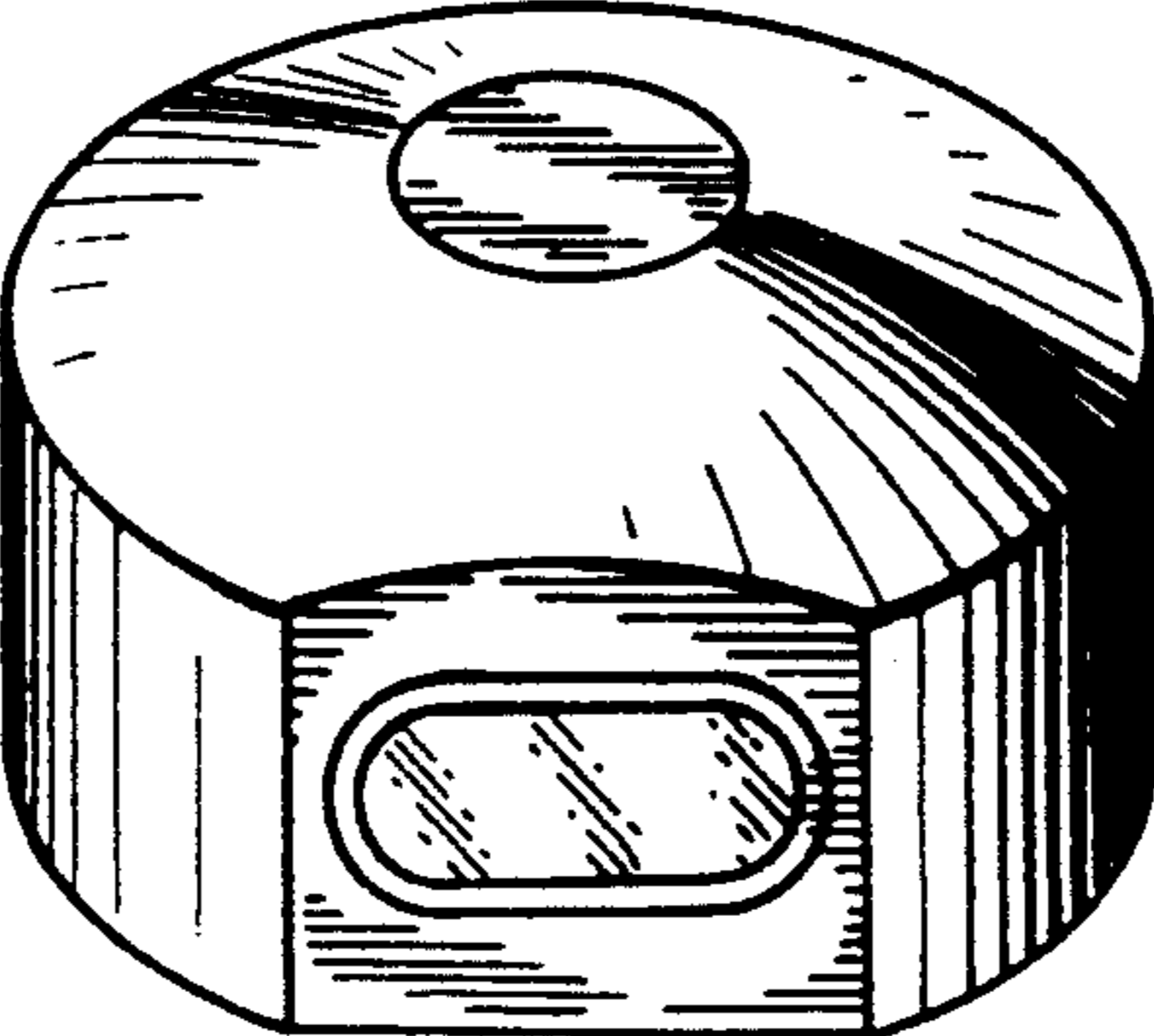

FIG. 2

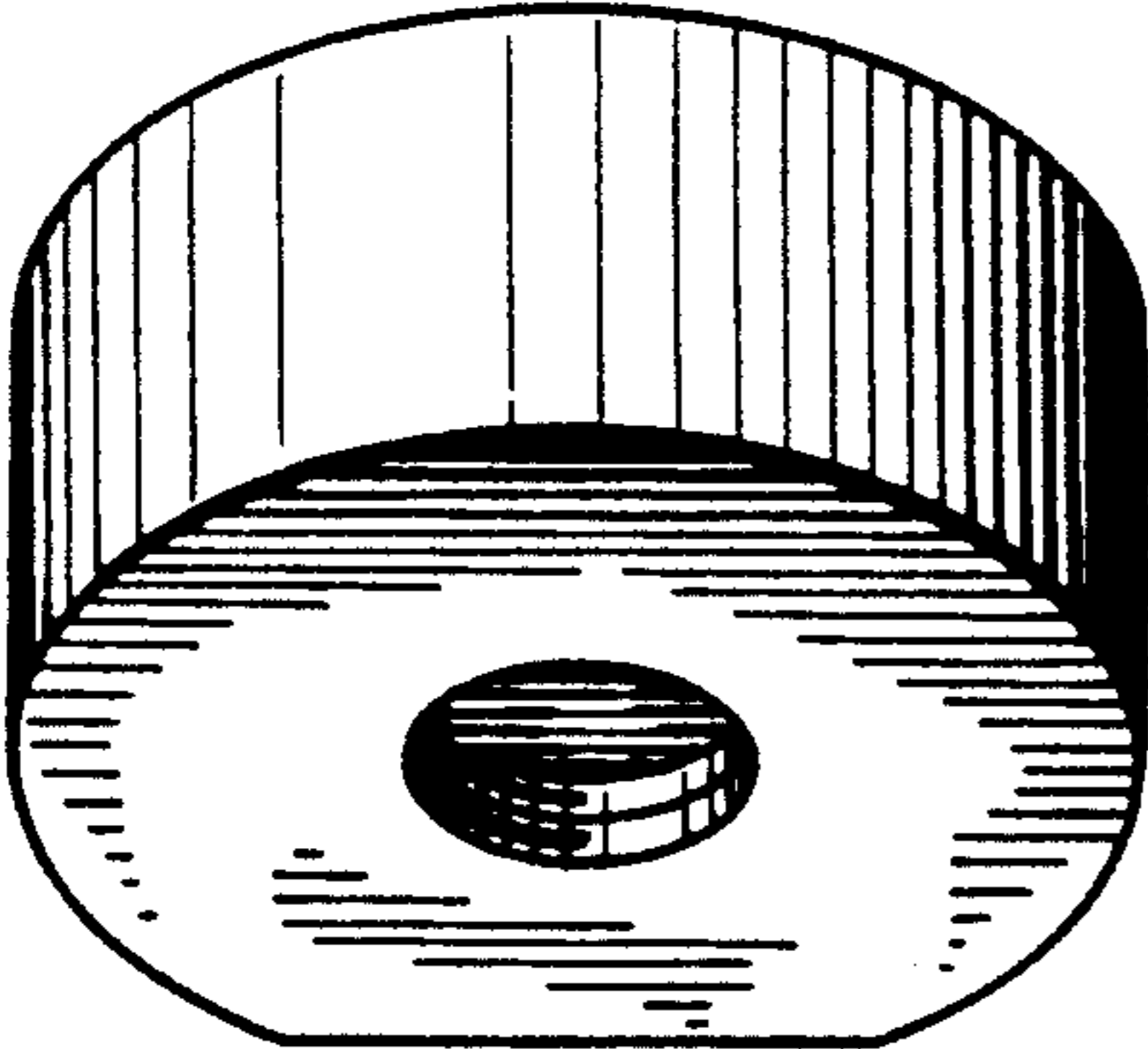

FIG. 3

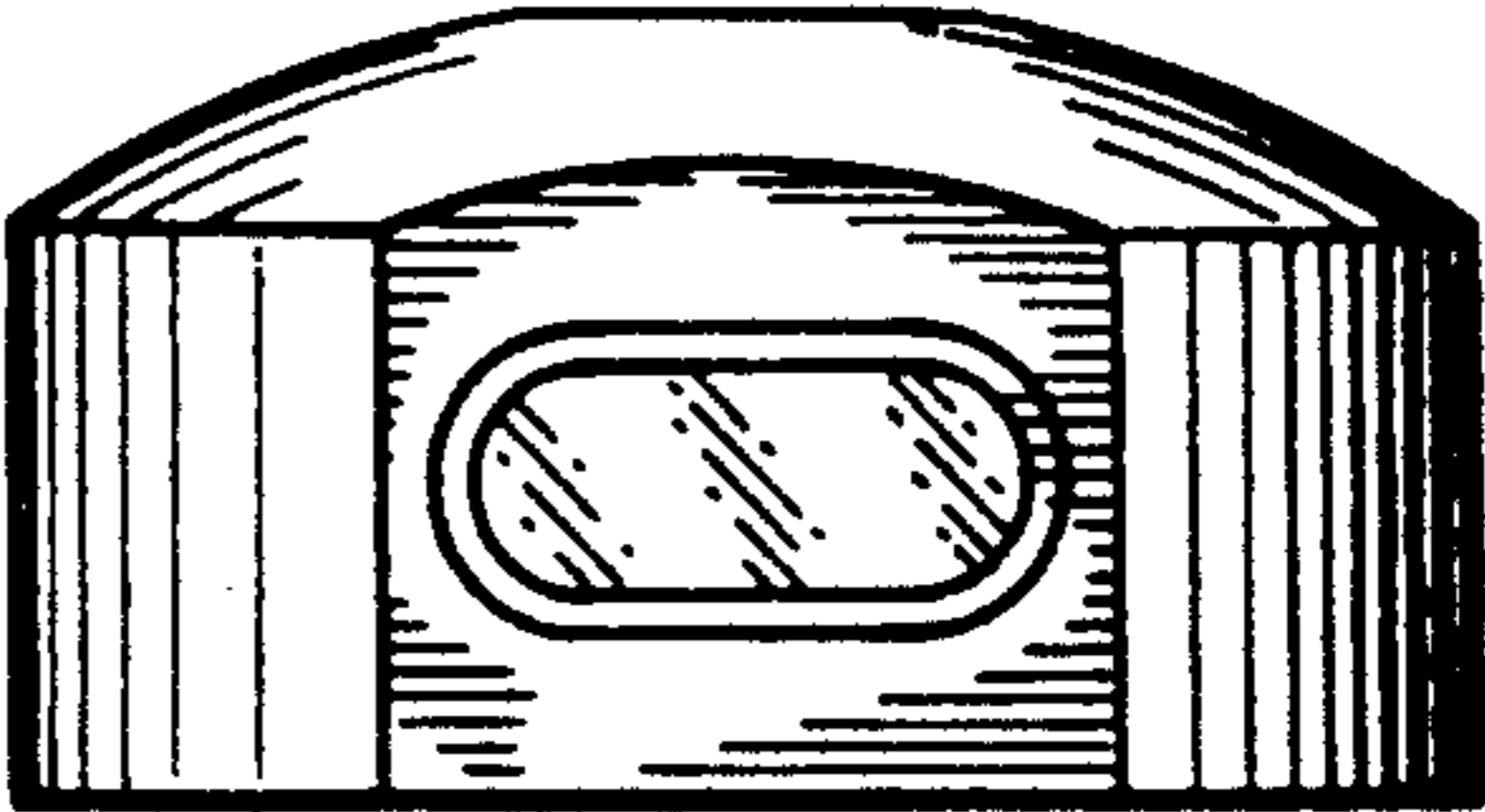

FIG. 4

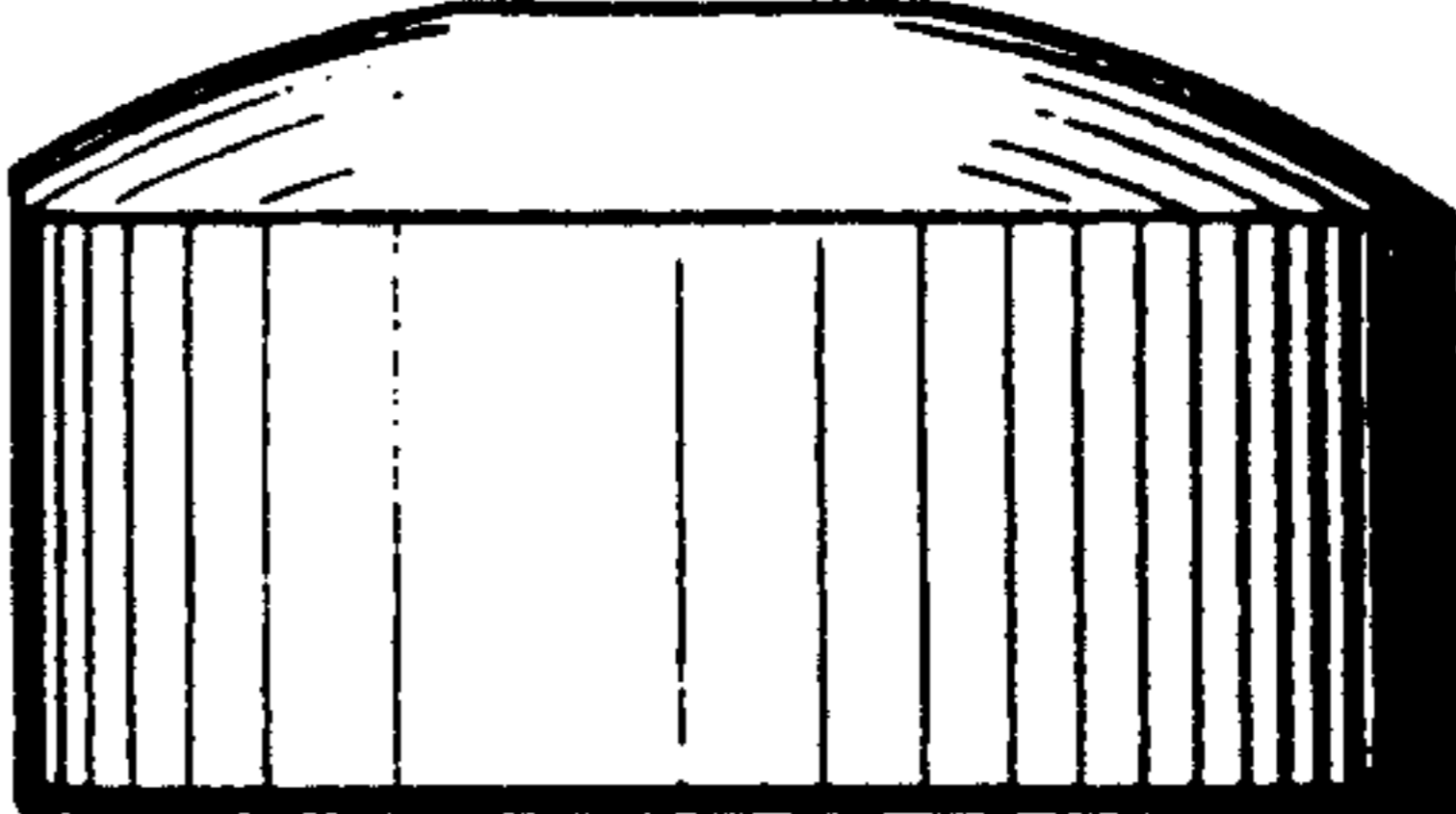

FIG. 5

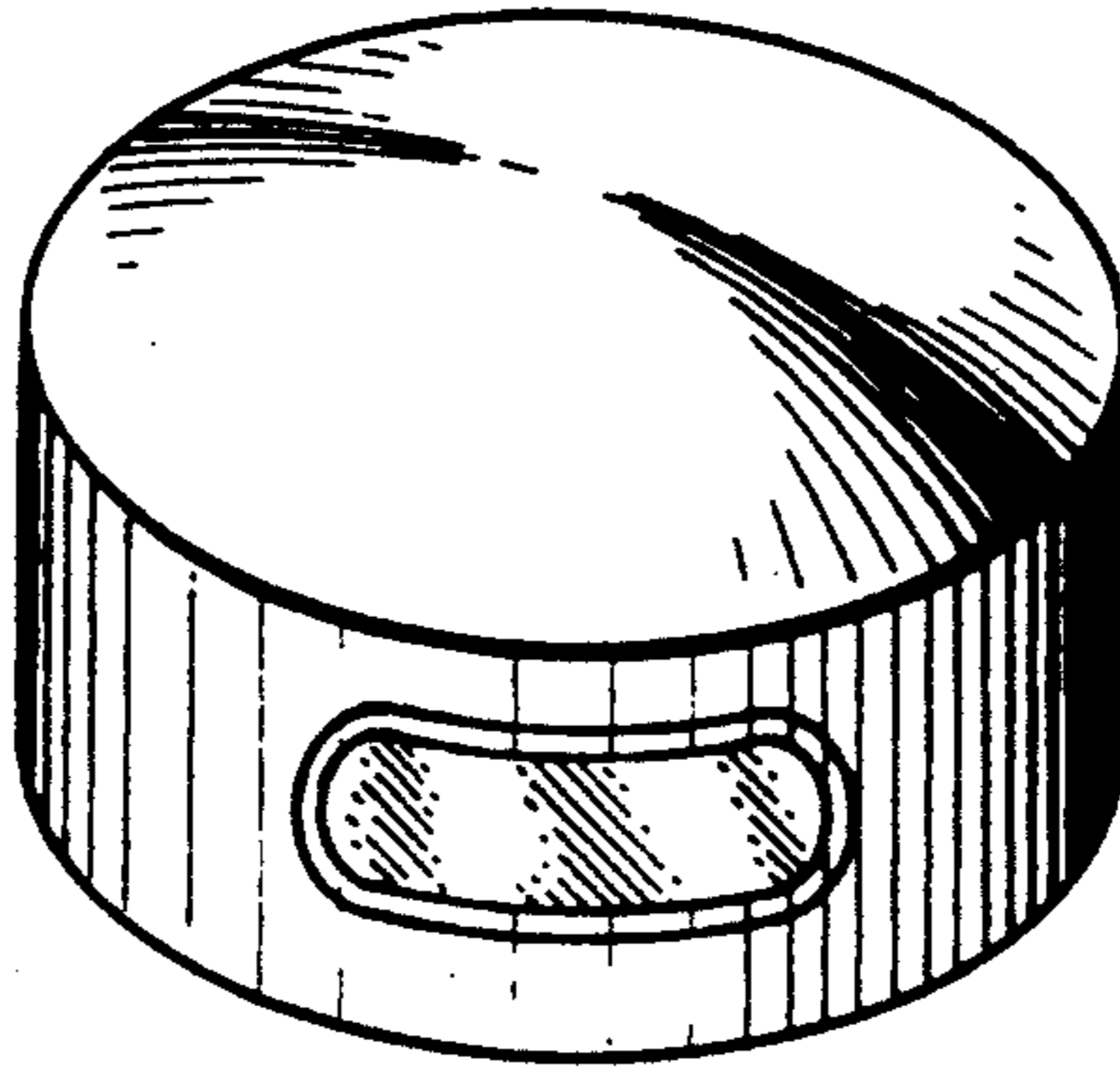

FIG. 6

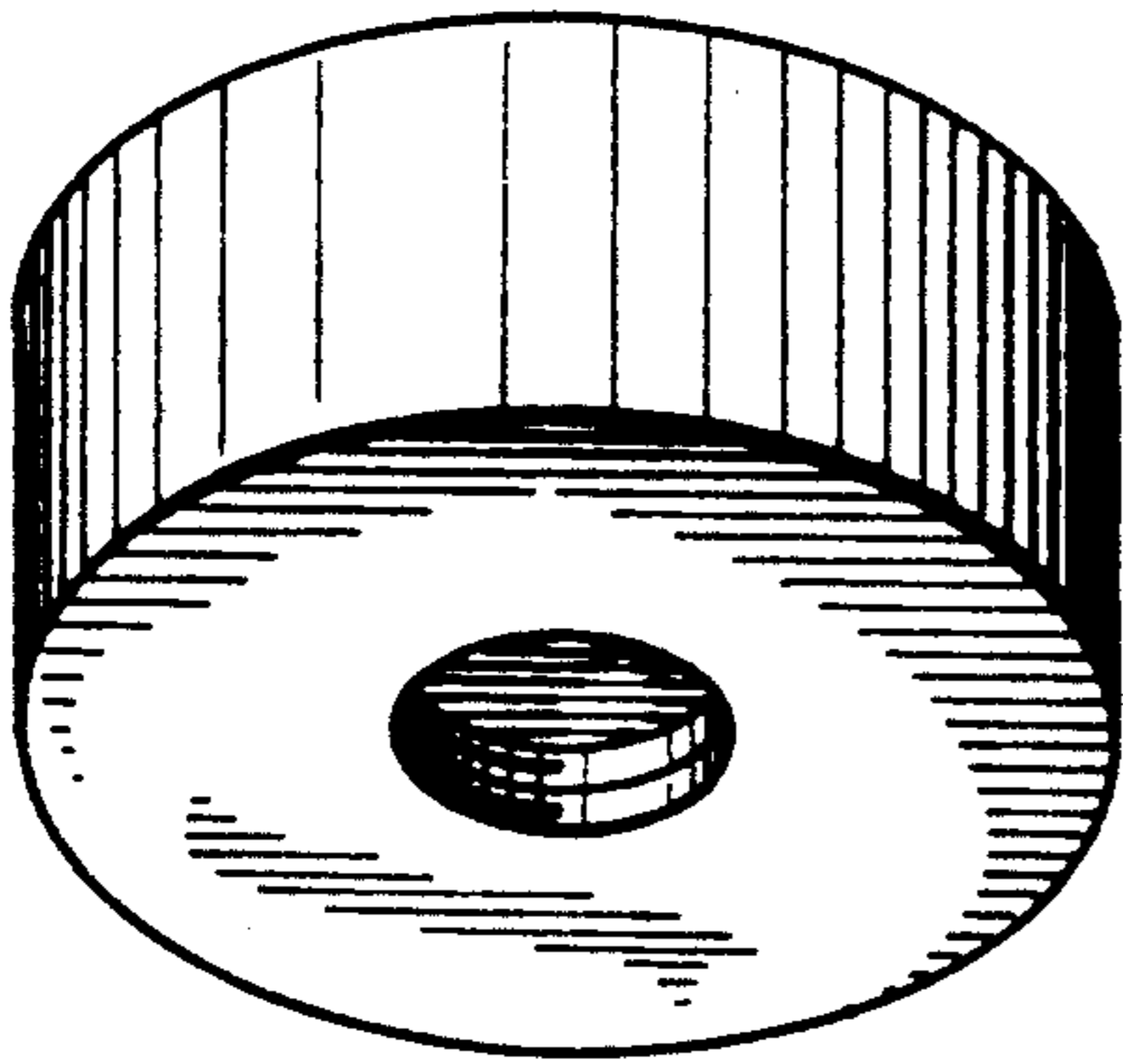

FIG. 7

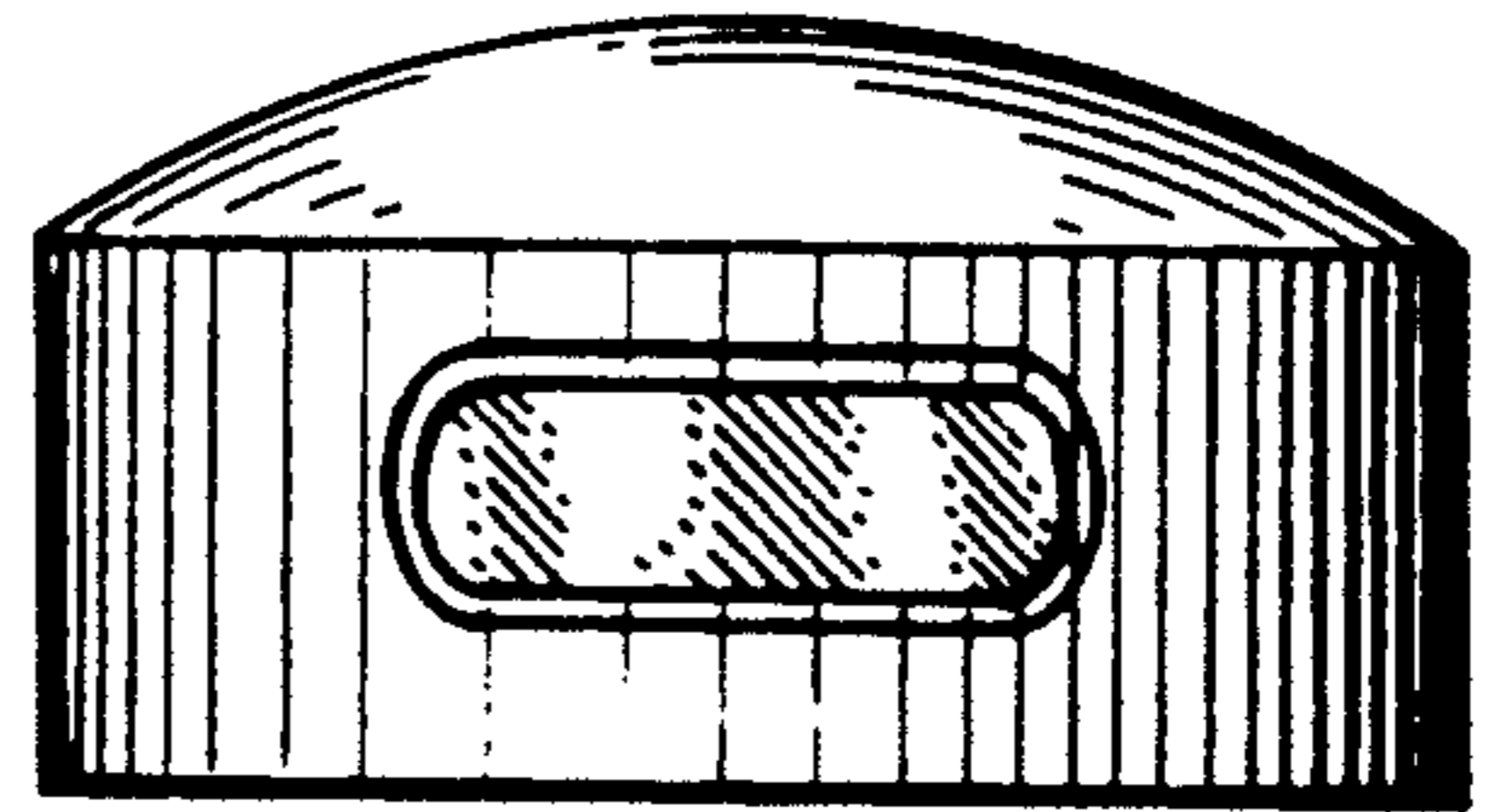
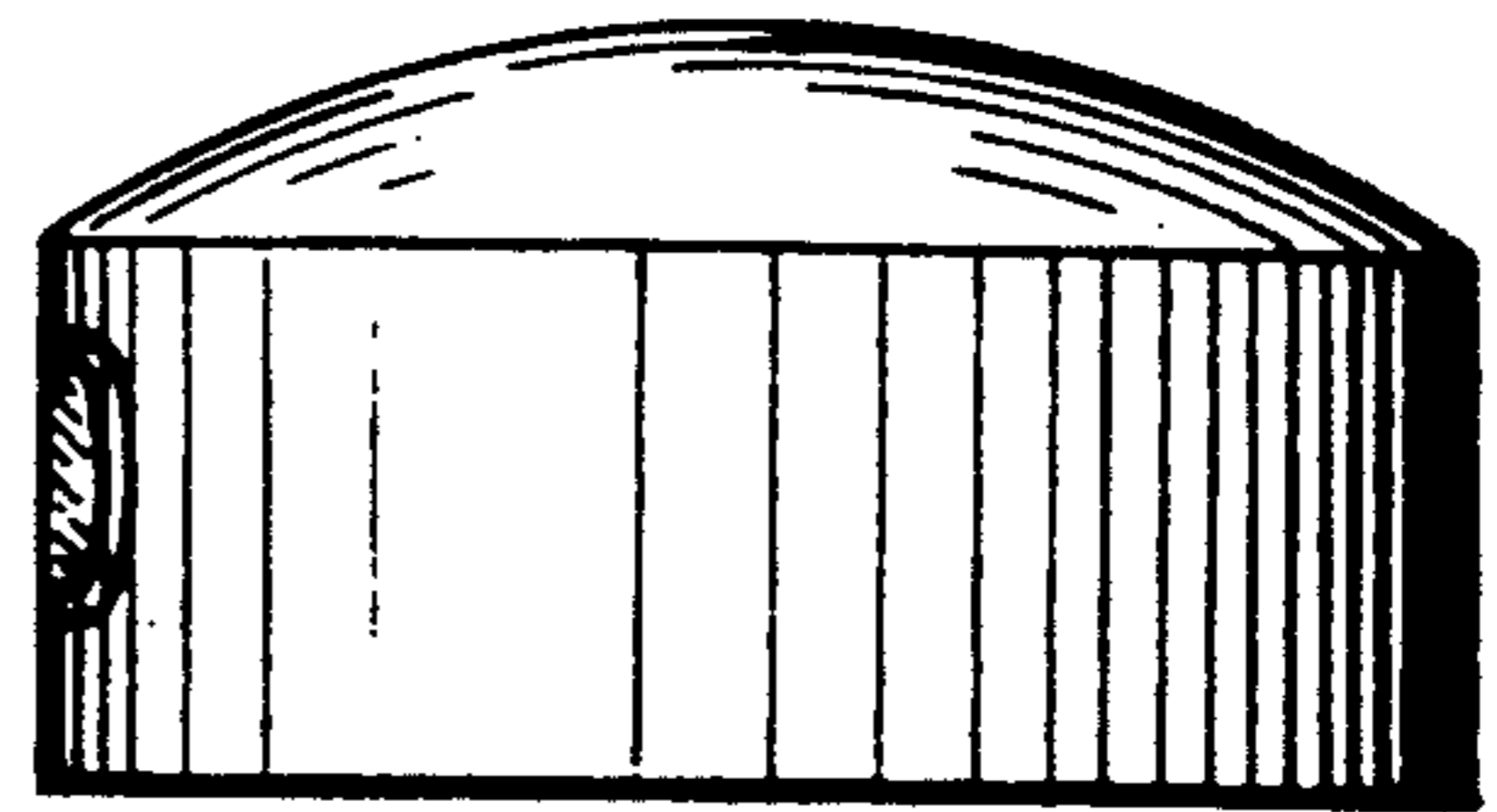

FIG. 8



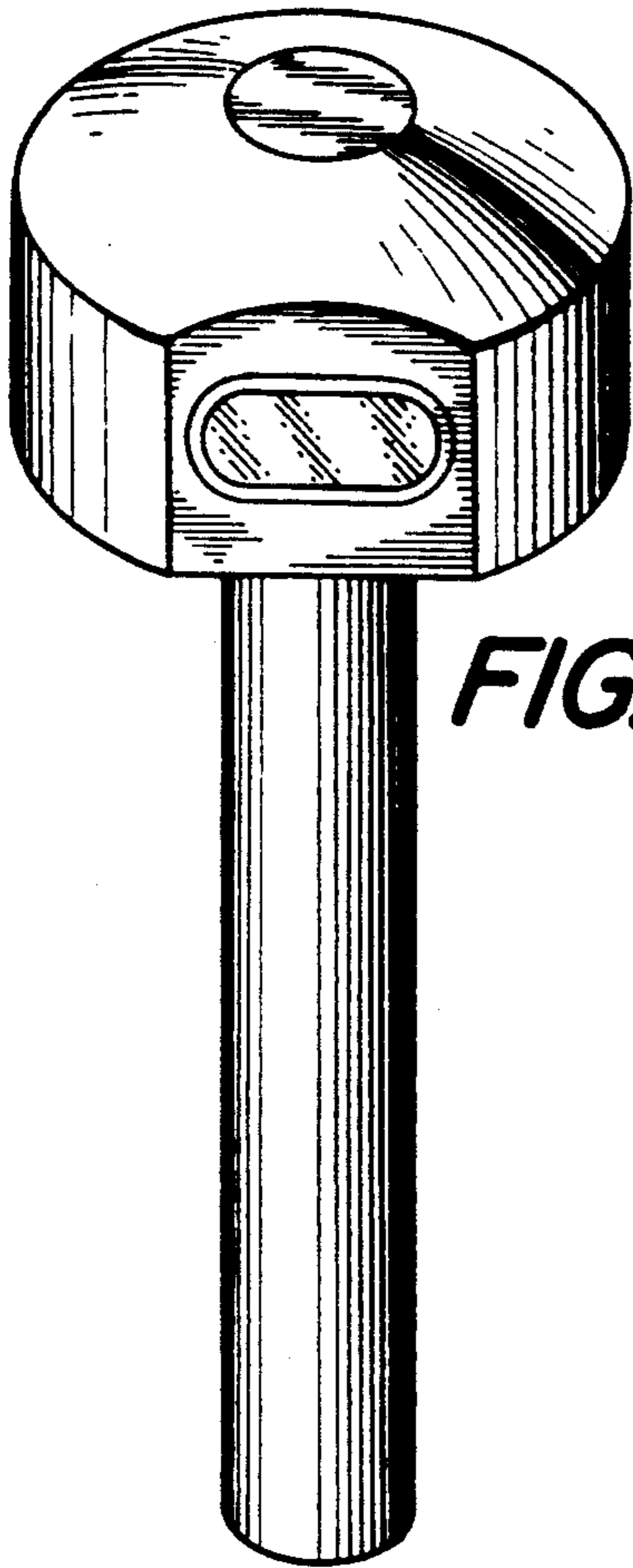

FIG. 9

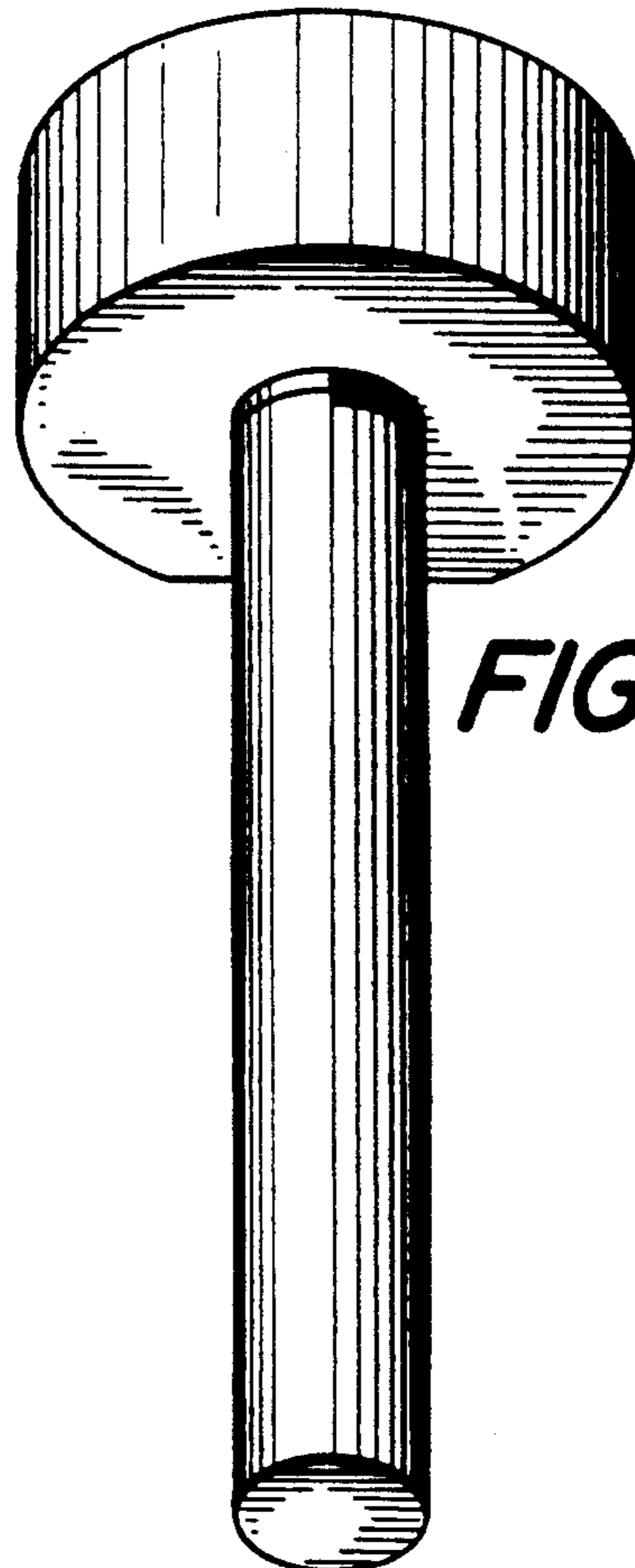

FIG. 10

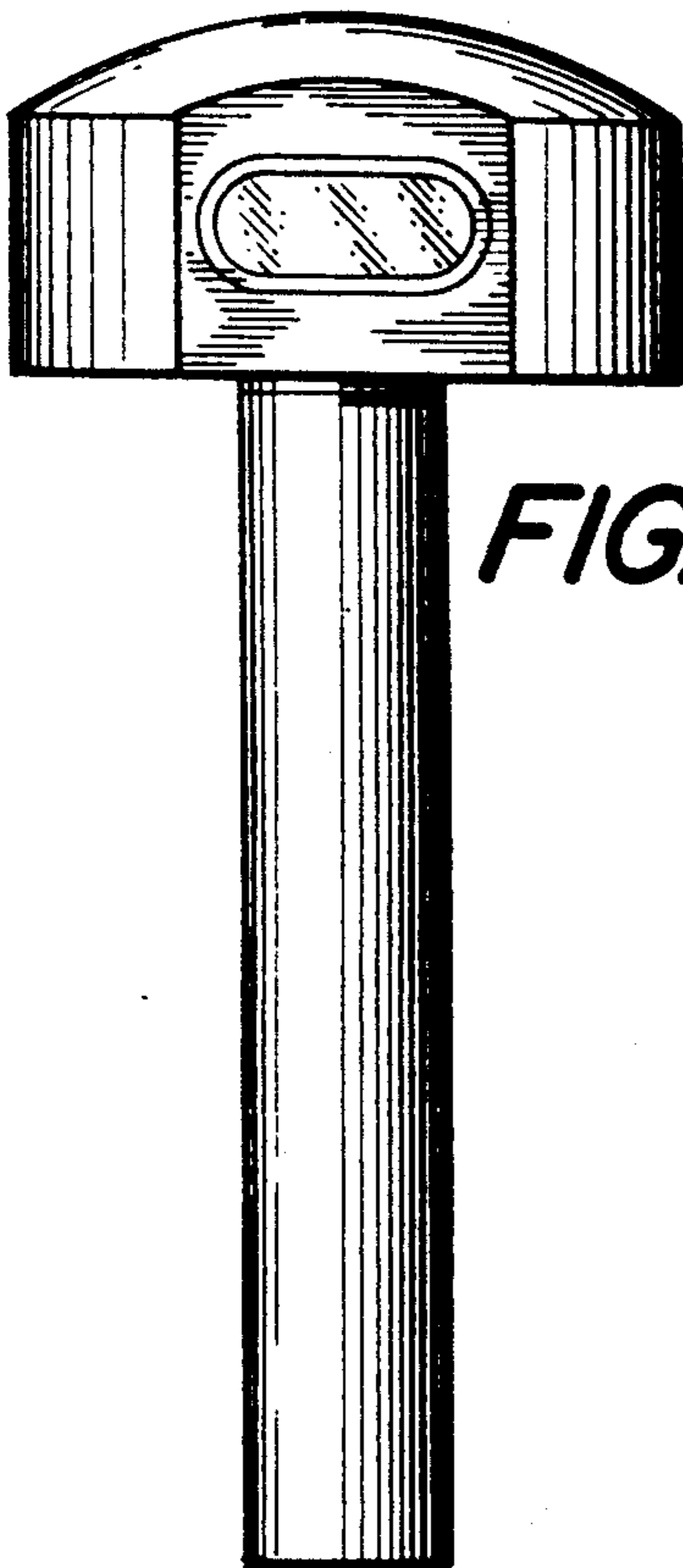

FIG. 11

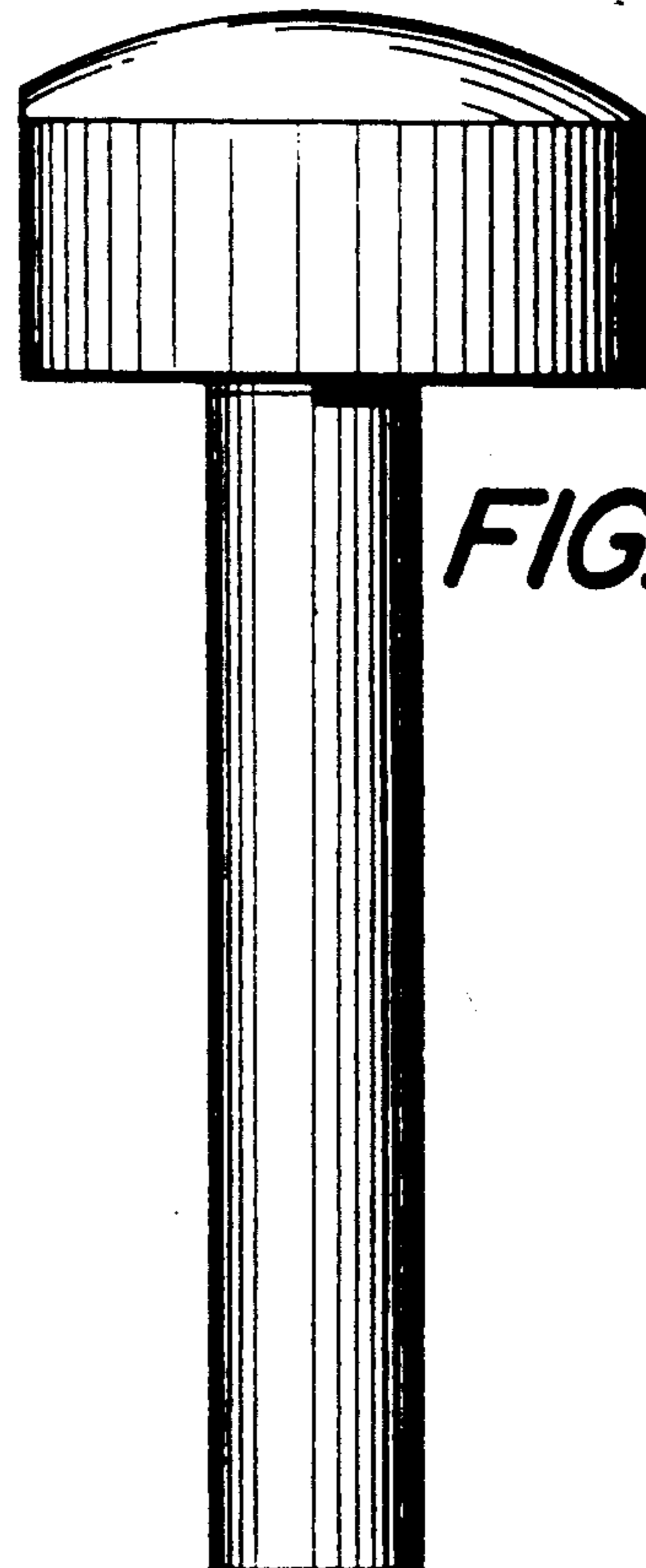

FIG. 12

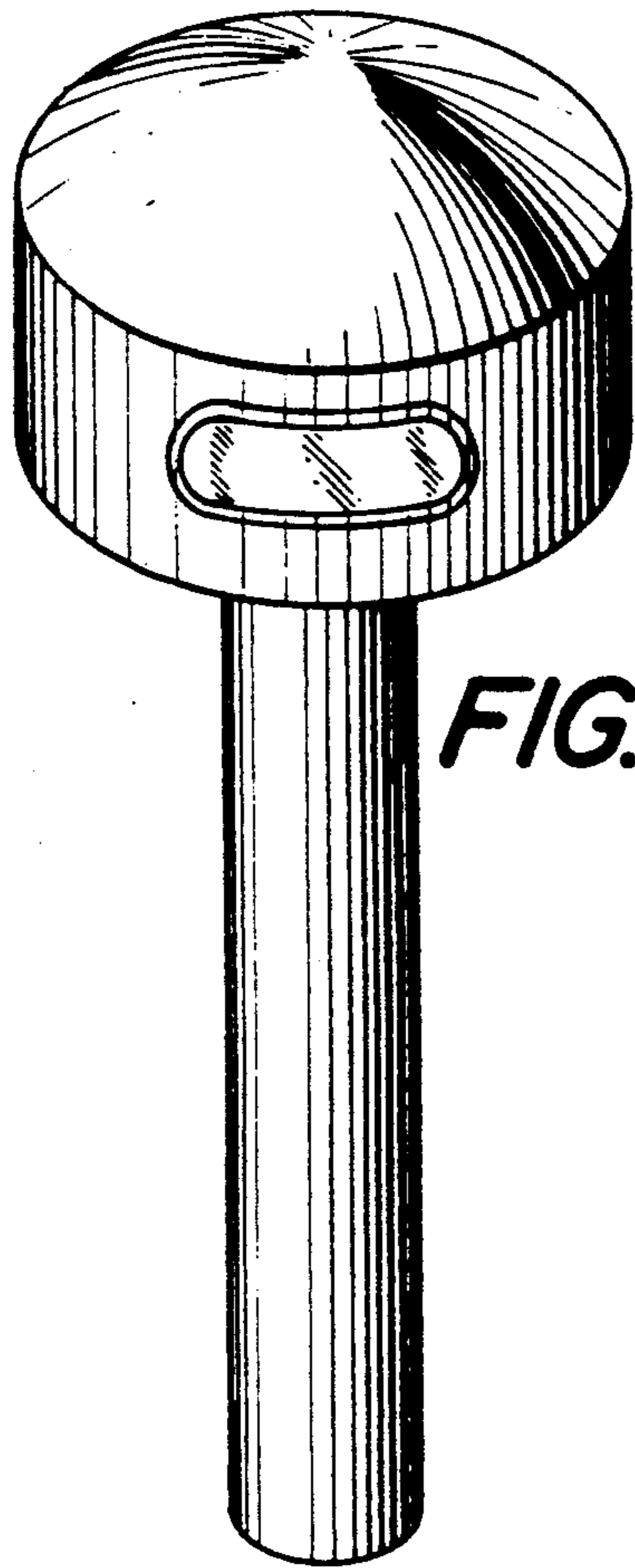

FIG. 13

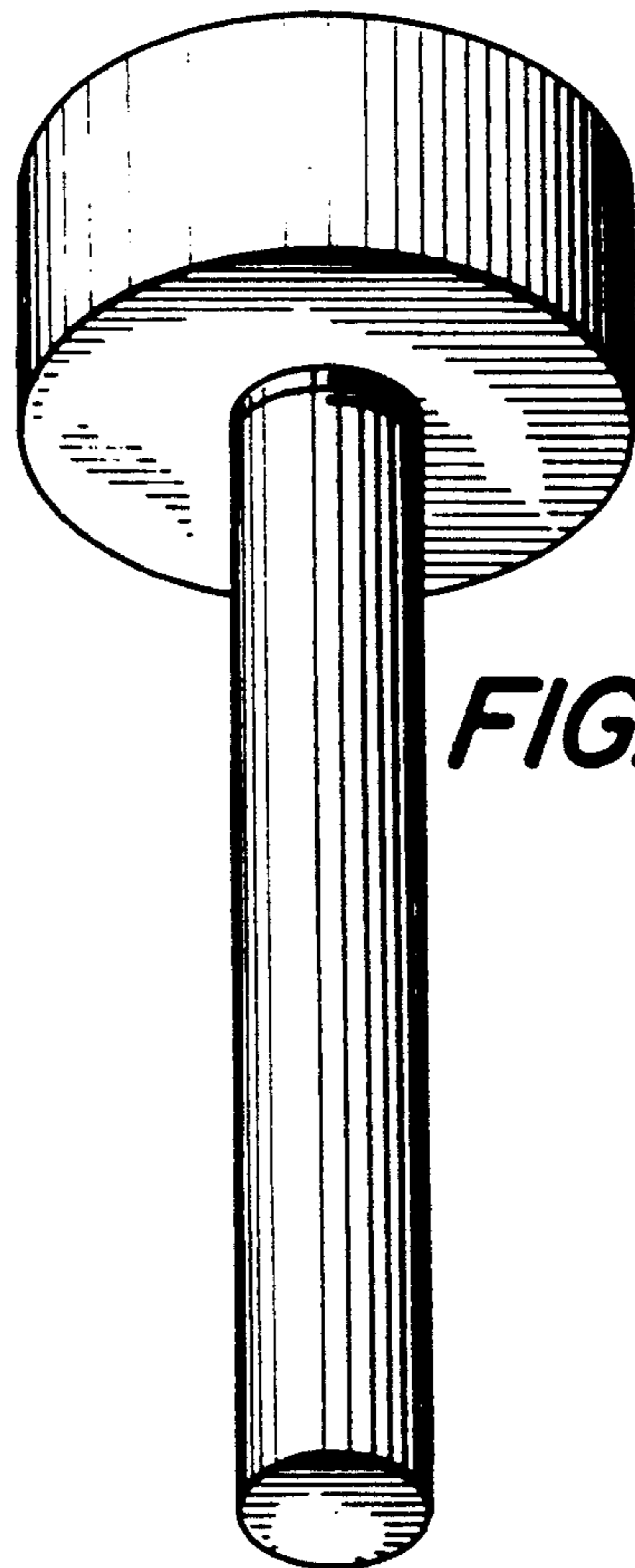

FIG. 14

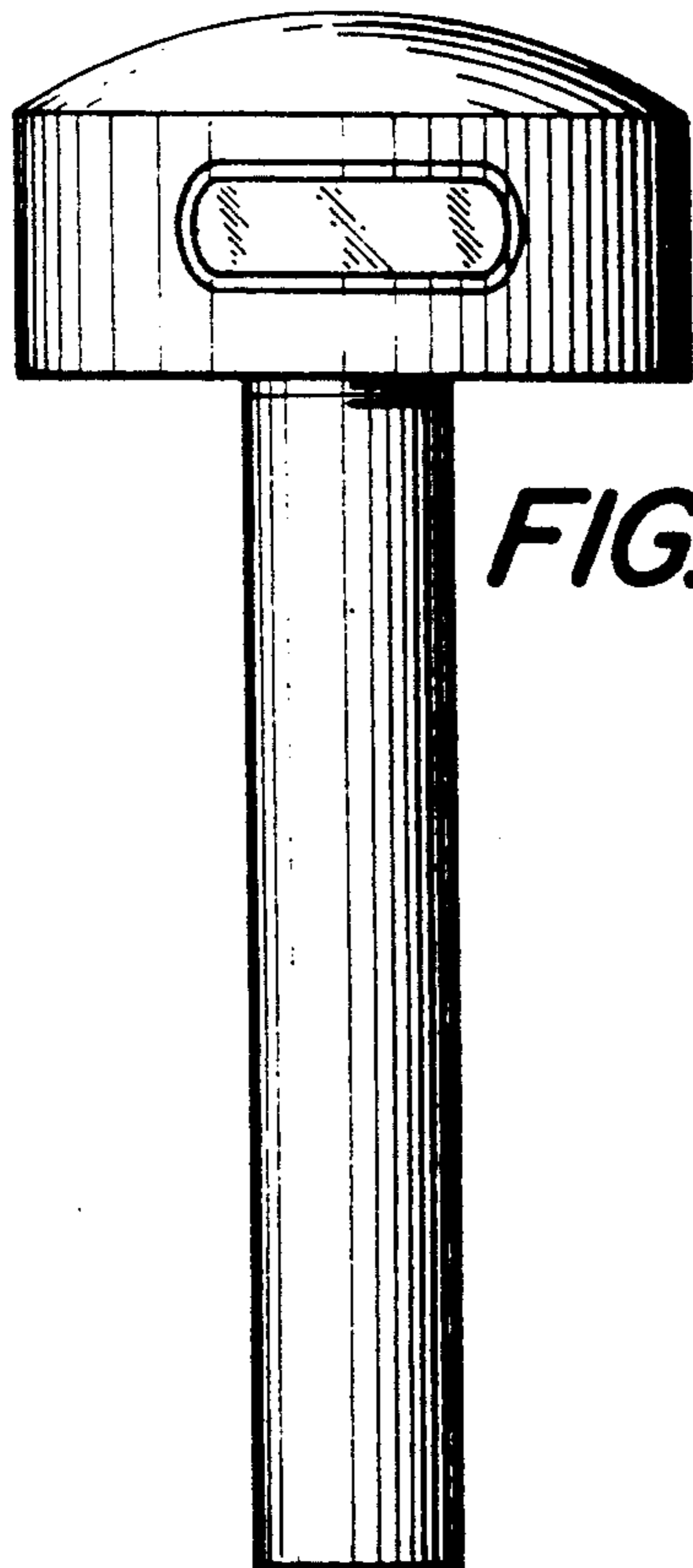

FIG. 15

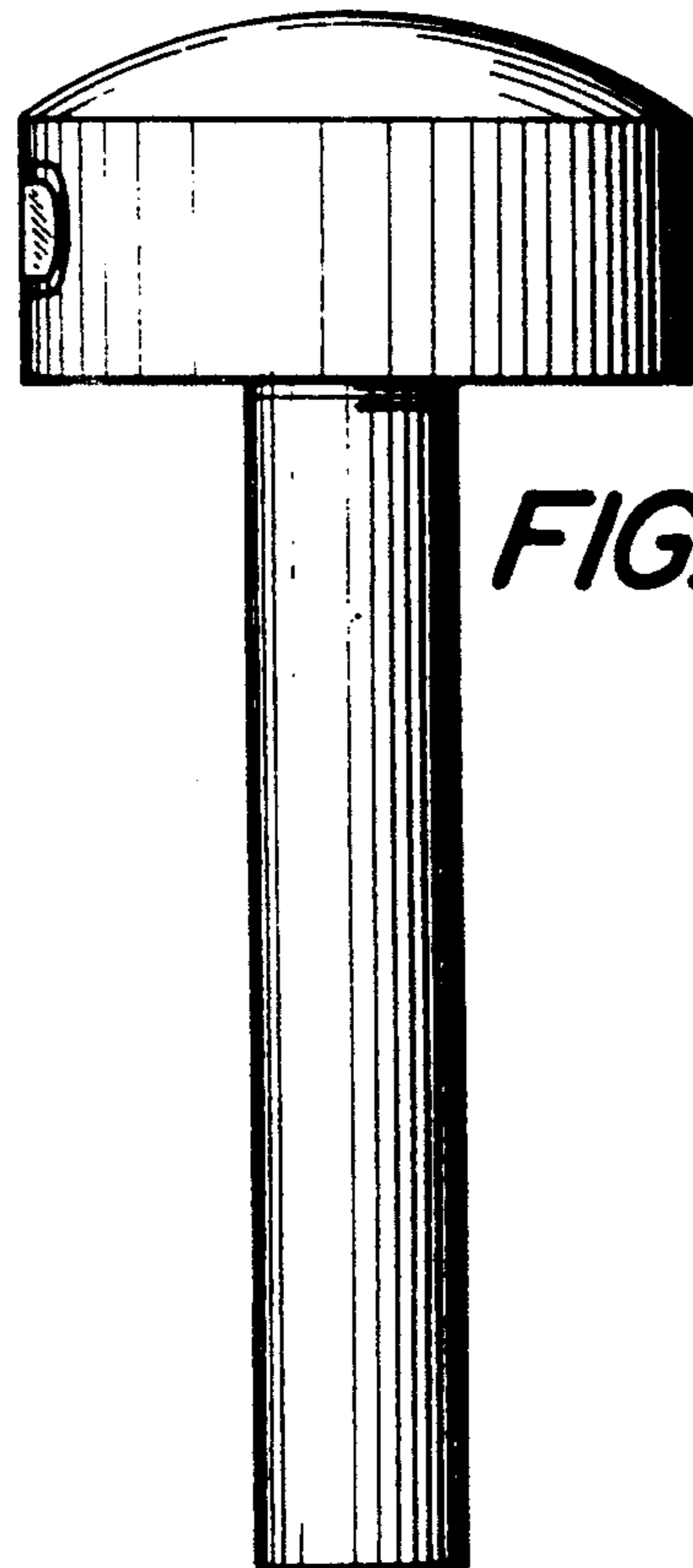

FIG. 16