



US00D332468S

# United States Patent [19]

[11] Patent Number: Des. 332,468

Tarozzi

[45] Date of Patent: \*\* Jan. 12, 1993

[54] **PORTABLE CONTAINER FOR WRITING INSTRUMENTS**

[75] Inventor: **Richard Tarozzi**, Gales Ferry, Conn.

[73] Assignee: **Binney & Smith Inc.**, Easton, Pa.

[\*\*] Term: **14 Years**

[21] Appl. No.: **734,334**

[22] Filed: **Jul. 19, 1991**

[52] U.S. Cl. .... **D19/85; D19/36; D3/30.1; D3/74**

[58] Field of Search ..... **D19/36, 35, 65, 75, D19/77, 81-85, 99, 100; D3/30.1, 74; 206/214, 224, 371; 211/69.1-69.9**

[56] **References Cited**

**U.S. PATENT DOCUMENTS**

D. 277,195	1/1985	Lahmer .....	D19/75 X
D. 315,446	3/1991	Dietterich et al. ....	D3/74
D. 316,934	5/1991	Stanfield .....	D3/74 X
565,710	8/1896	Tollner .	
870,771	11/1907	Garman .	
873,421	12/1907	Fleming .....	211/69.9
1,054,487	2/1913	Bagley .	
1,130,811	3/1915	Goldsmith .....	206/371 X
1,687,136	10/1928	Myers .....	211/69.9
1,911,799	5/1933	Buchan .	
1,957,039	5/1934	Buenger et al. .	
2,228,493	1/1941	Will .	
3,195,925	7/1965	Walker .	
4,380,293	4/1983	Wilcox et al. ....	206/214 X
4,475,650	10/1984	De Fazio, Jr. ....	206/224 X

4,573,569	3/1986	Parker .	
4,616,851	10/1986	Mann .	
4,648,505	3/1987	Belmondo .....	206/214
4,793,633	12/1988	Rose .	
4,815,622	3/1989	Cramer .	
4,875,707	10/1989	Krom .	
4,893,711	1/1990	Gustafson .	

**FOREIGN PATENT DOCUMENTS**

1265215 5/1960 France .

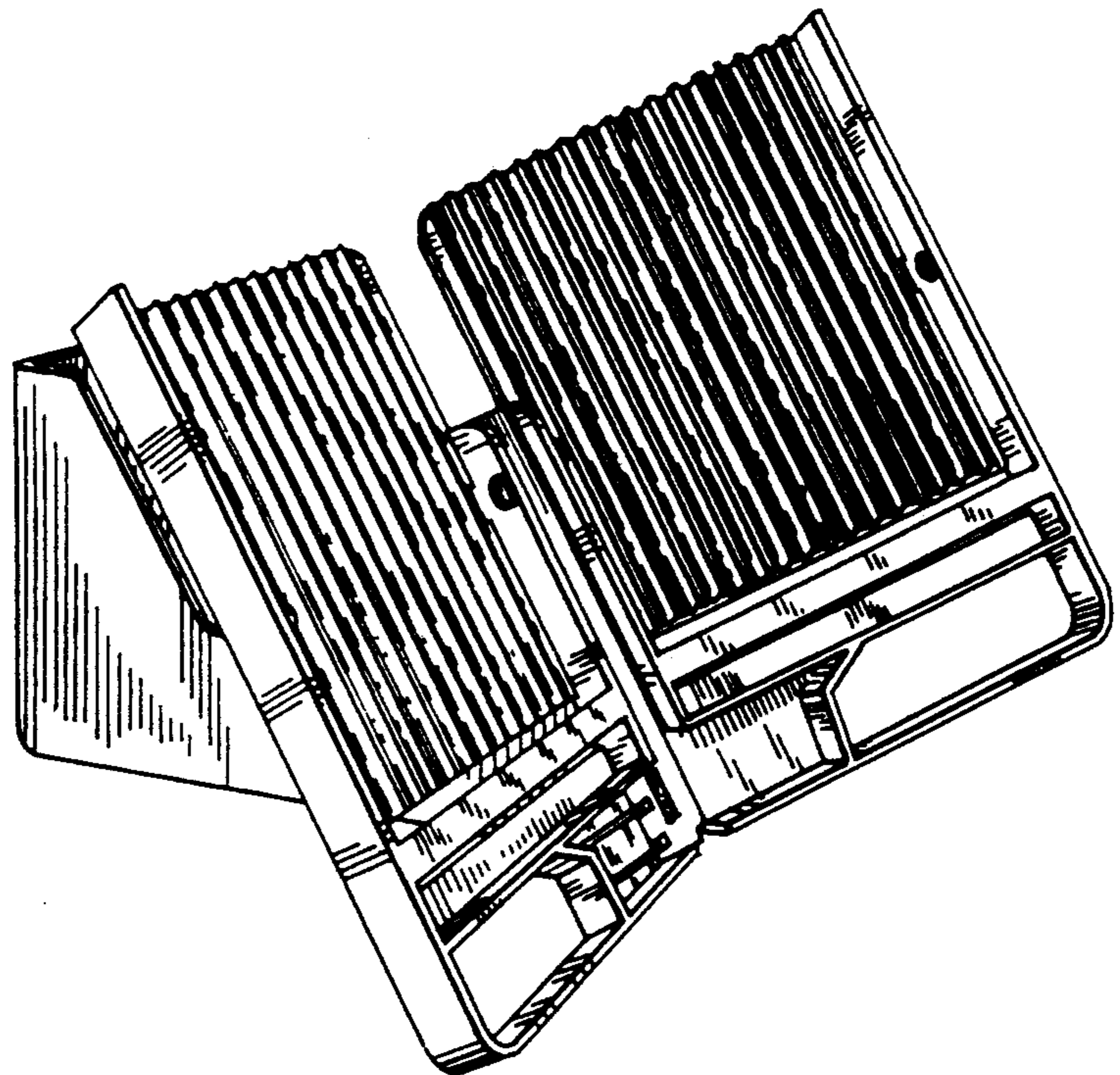
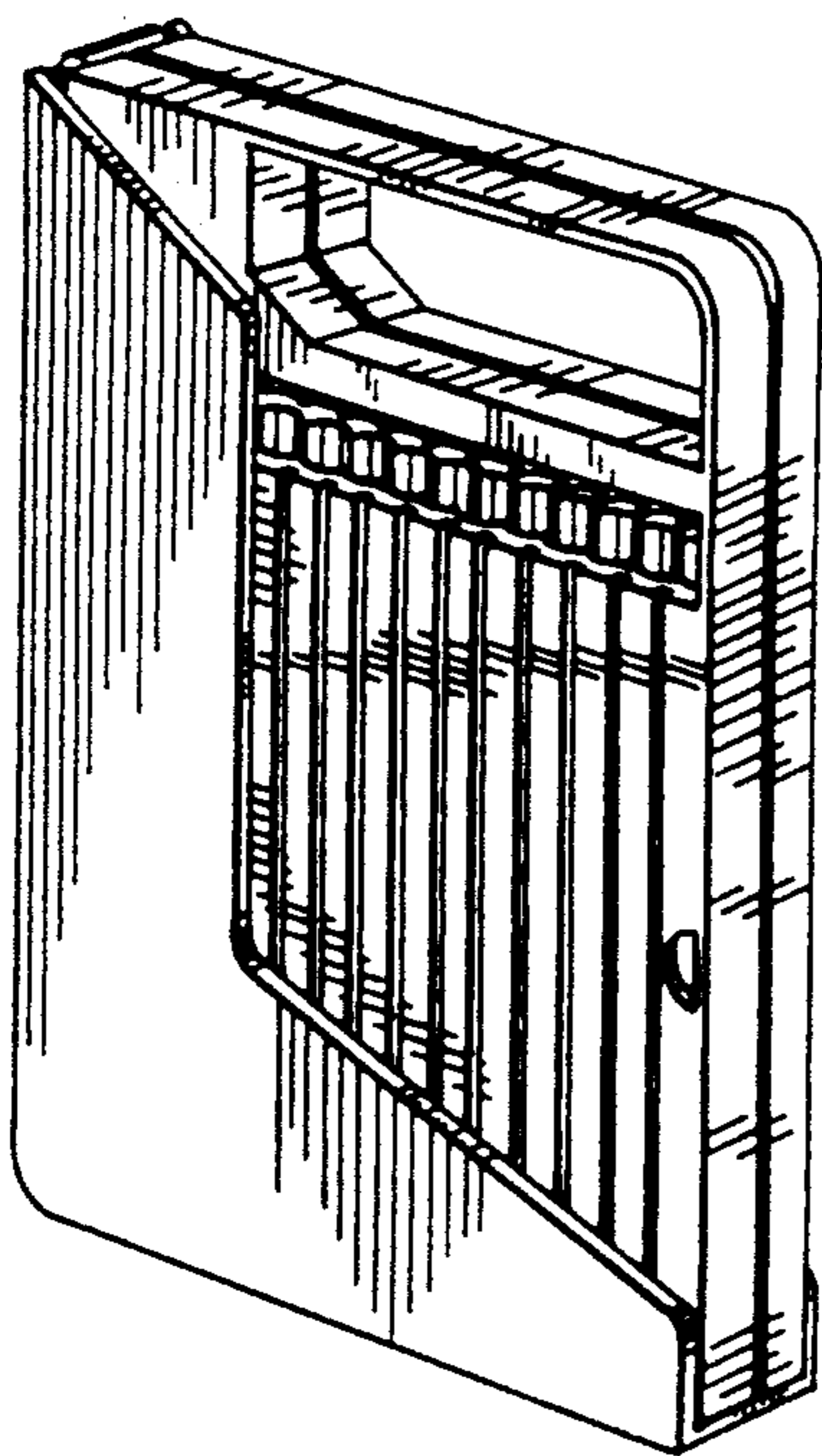
*Primary Examiner*—Nelson C. Holtje  
*Assistant Examiner*—Martha Thompson  
*Attorney, Agent, or Firm*—Leydig, Voit & Mayer

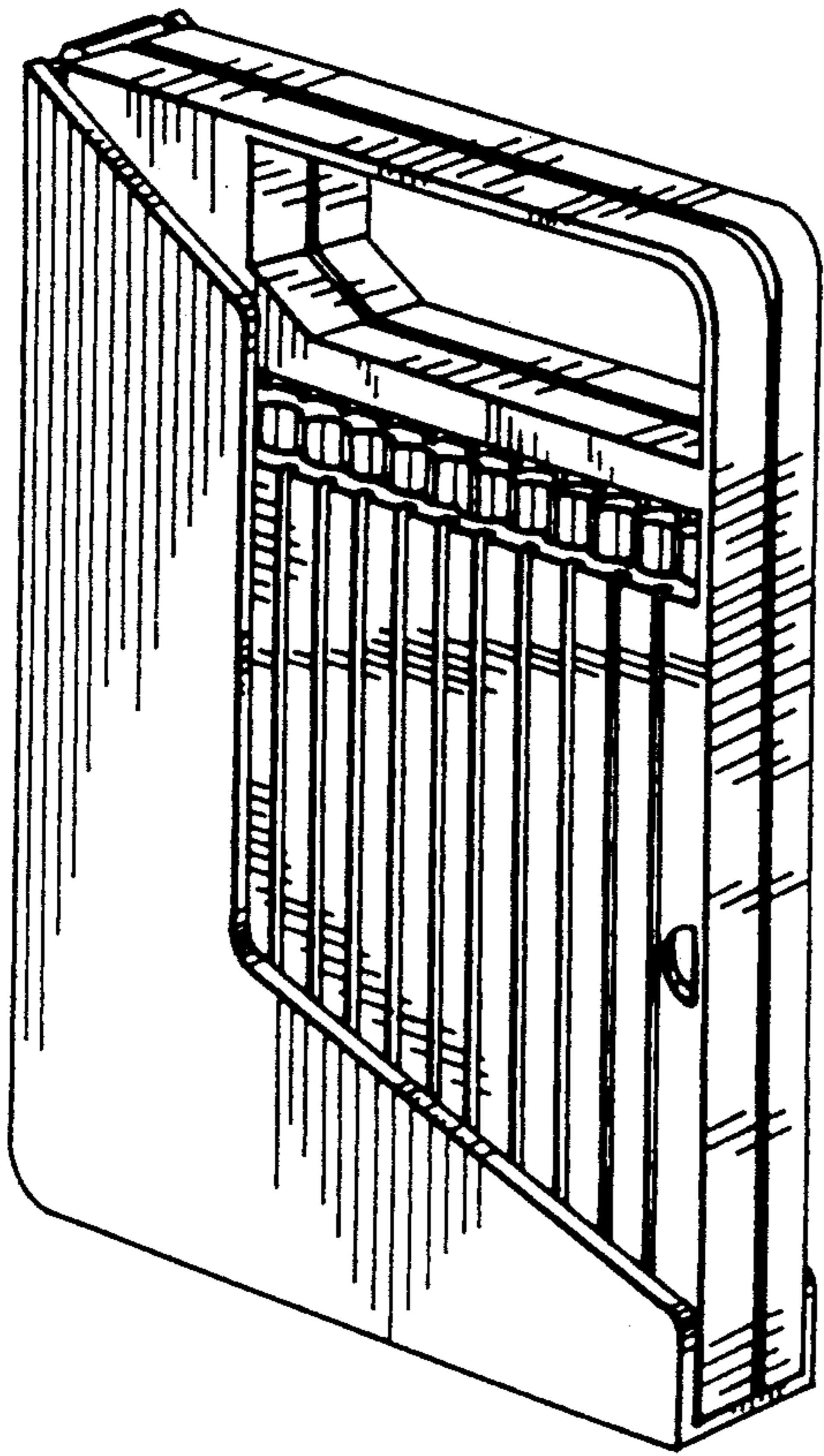
[57] **CLAIM**

The ornamental design for a portable container for writing instruments, as shown and described.

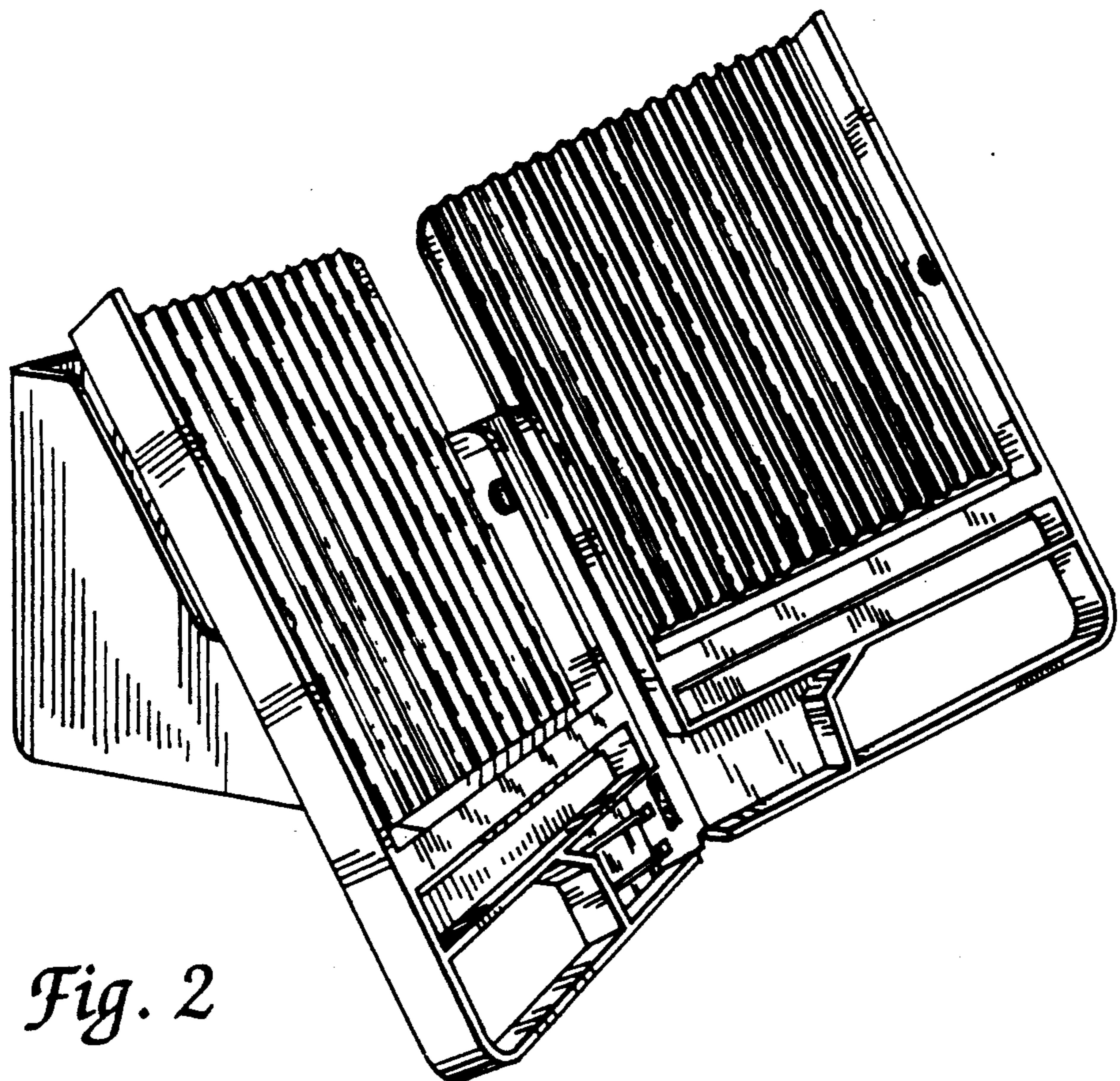
**DESCRIPTION**

FIG. 1 is a top, left front perspective view of a portable container for writing instruments showing my new design;  
FIG. 2 is a top, left front perspective view in an opened condition;  
FIG. 3 is a left side elevational view of FIG. 1;  
FIG. 4 is a front elevational view of FIG. 1;  
FIG. 5 is a right side elevational view of FIG. 1;  
FIG. 6 is a bottom plan view of FIG. 1;  
FIG. 7 is a top plan view of FIG. 1; and,  
FIG. 8 is a rear elevational view of FIG. 1.  
FIGS. 3 through 8 have been drawn to an enlarged scale with respect to FIGS. 1 and 2.



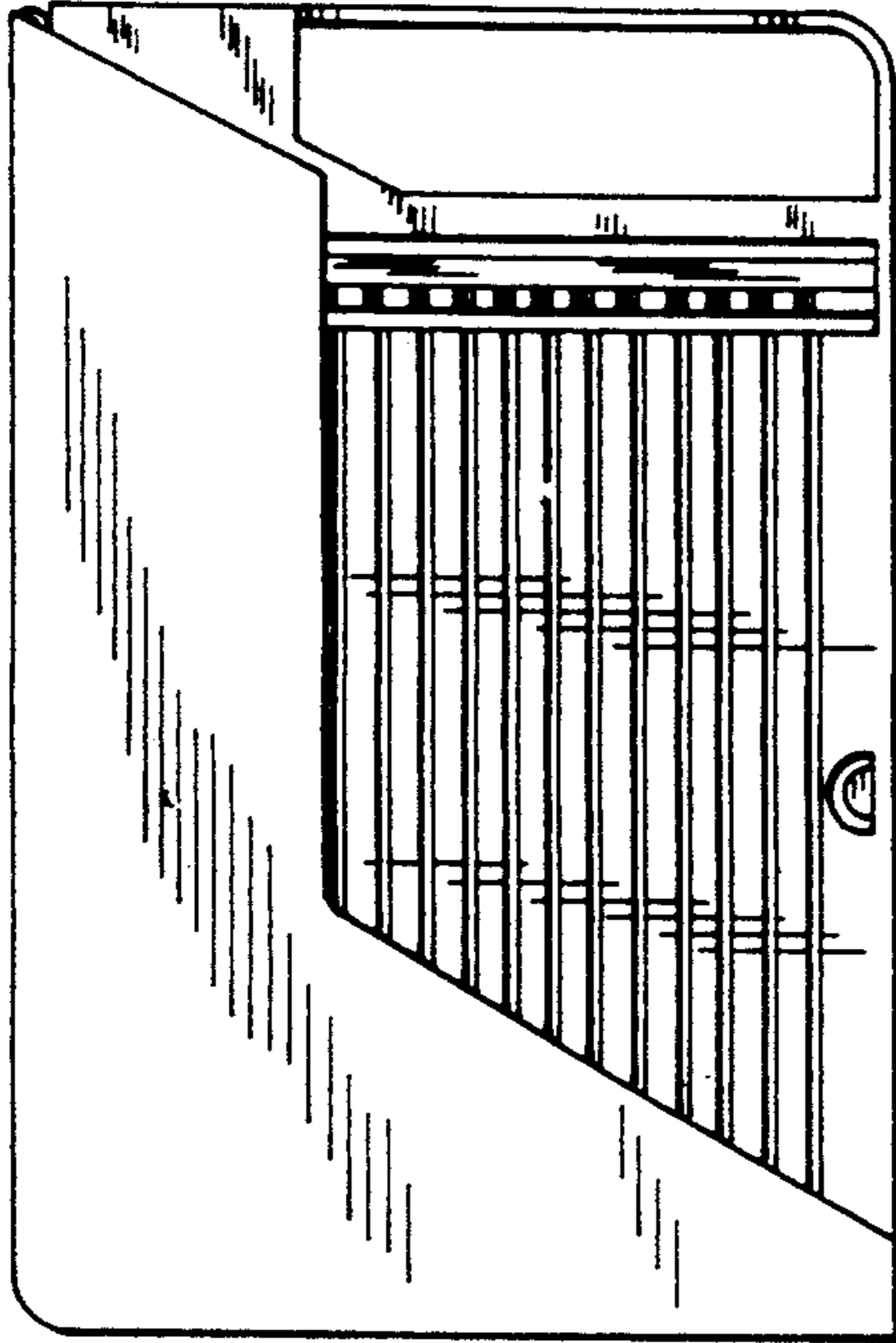


*Fig. 1*

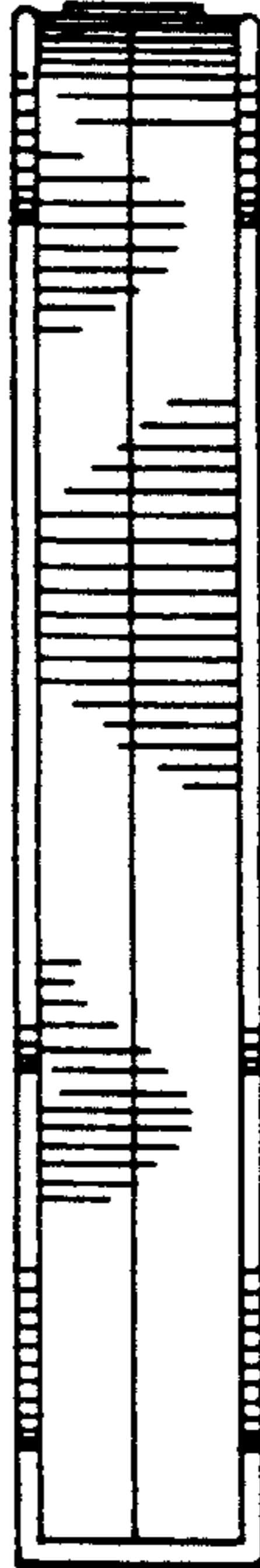


*Fig. 2*

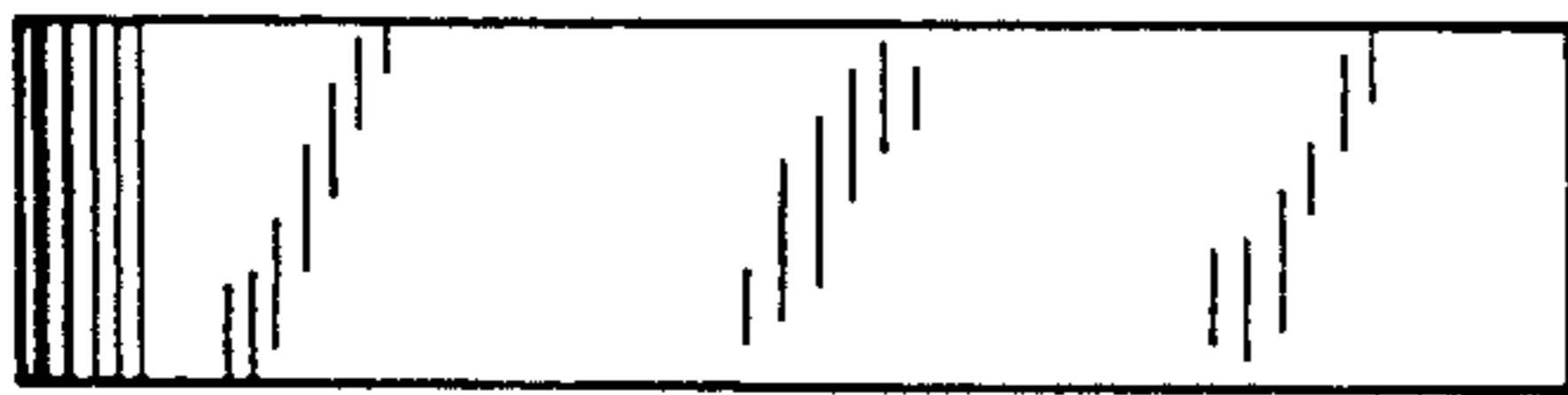
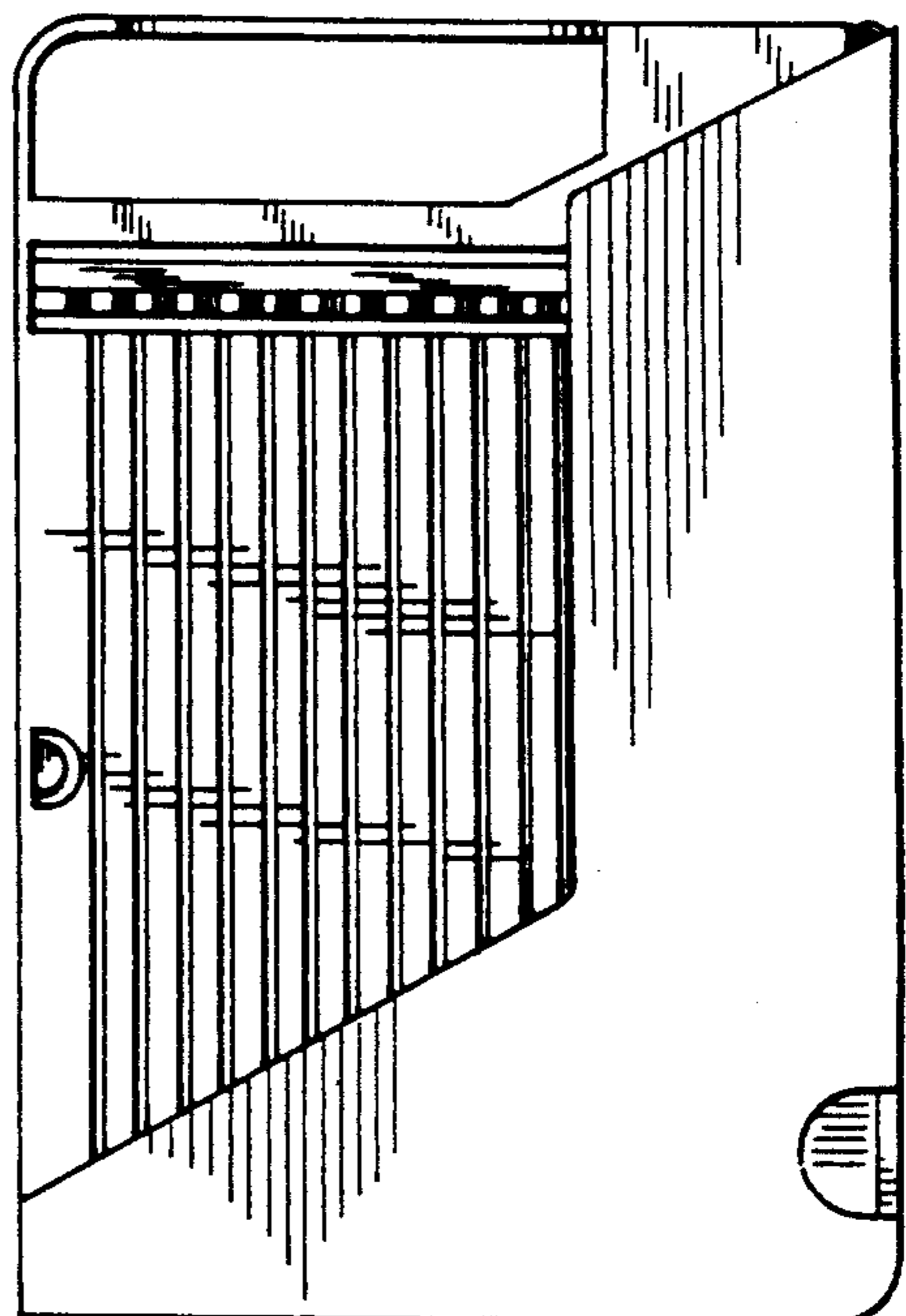
*Fig. 3*



*Fig. 4*



*Fig. 5*



*Fig. 6*



*Fig. 8*

*Fig. 7*

