



US00D332466S

United States Patent [19]

[11] Patent Number: **Des. 332,466**

Logan

[45] Date of Patent: **** Jan. 12, 1993**

[54] **COMBINED MULTI-PANELED EASEL AND ART DISPLAY CASE**

[76] Inventor: **Genevieve R. Logan**, 627 Mauze, San Antonio, Tex. 78216

[*] Notice: The portion of the term of this patent subsequent to May 19, 2006 has been disclaimed.

[**] Term: **14 Years**

[21] Appl. No.: **352,814**

[22] Filed: **May 17, 1989**

[52] U.S. Cl. **D19/36; D19/35; D19/52; D3/74**

[58] Field of Search **D20/10; D3/73, 74; D19/35, 36, 52, 65, 86, 90, 91; 206/1.7-1.9, 214, 371; 190/900, 901; 248/444; 40/530**

[56] **References Cited**

U.S. PATENT DOCUMENTS

D. 221,012	6/1971	Holland et al.	D19/52
D. 225,588	12/1972	Testro	D3/74
D. 250,973	1/1979	Ramsey	D3/74
D. 252,535	7/1979	MacEvoy	D3/74
D. 270,305	8/1983	Errigo	D3/74
D. 270,358	8/1983	Errigo	D3/73 X
D. 271,027	10/1983	Tripp	D19/52

D. 271,919	12/1983	Duffy	D3/74
D. 326,279	5/1992	Logan	D19/36
3,325,934	6/1967	Rhude	40/350
4,061,224	12/1977	Fuhri	206/1.7
4,318,471	3/1982	Hutton	206/214

Primary Examiner—Nelson C. Holtje
Assistant Examiner—Martha Thompson
Attorney, Agent, or Firm—John C. Stahl

[57] **CLAIM**

The ornamental design for a combined multi-paneled easel and art display case, as shown and described.

DESCRIPTION

FIG. 1 is a top, left front perspective view of a combined multi-paneled easel and art display case showing my new design;
 FIG. 2 is a front elevational view thereof;
 FIG. 3 is a left side elevational view, the right side being a mirror image thereof;
 FIG. 4 is a top plan view thereof;
 FIG. 5 is a rear elevational view thereof;
 FIG. 6 is a bottom plan view thereof;
 FIG. 7 is a front elevational view in a partially opened condition;
 FIG. 8 is a front elevational view in a fully opened condition; and,
 FIG. 9 is a top front perspective view in an alternate partially opened condition.

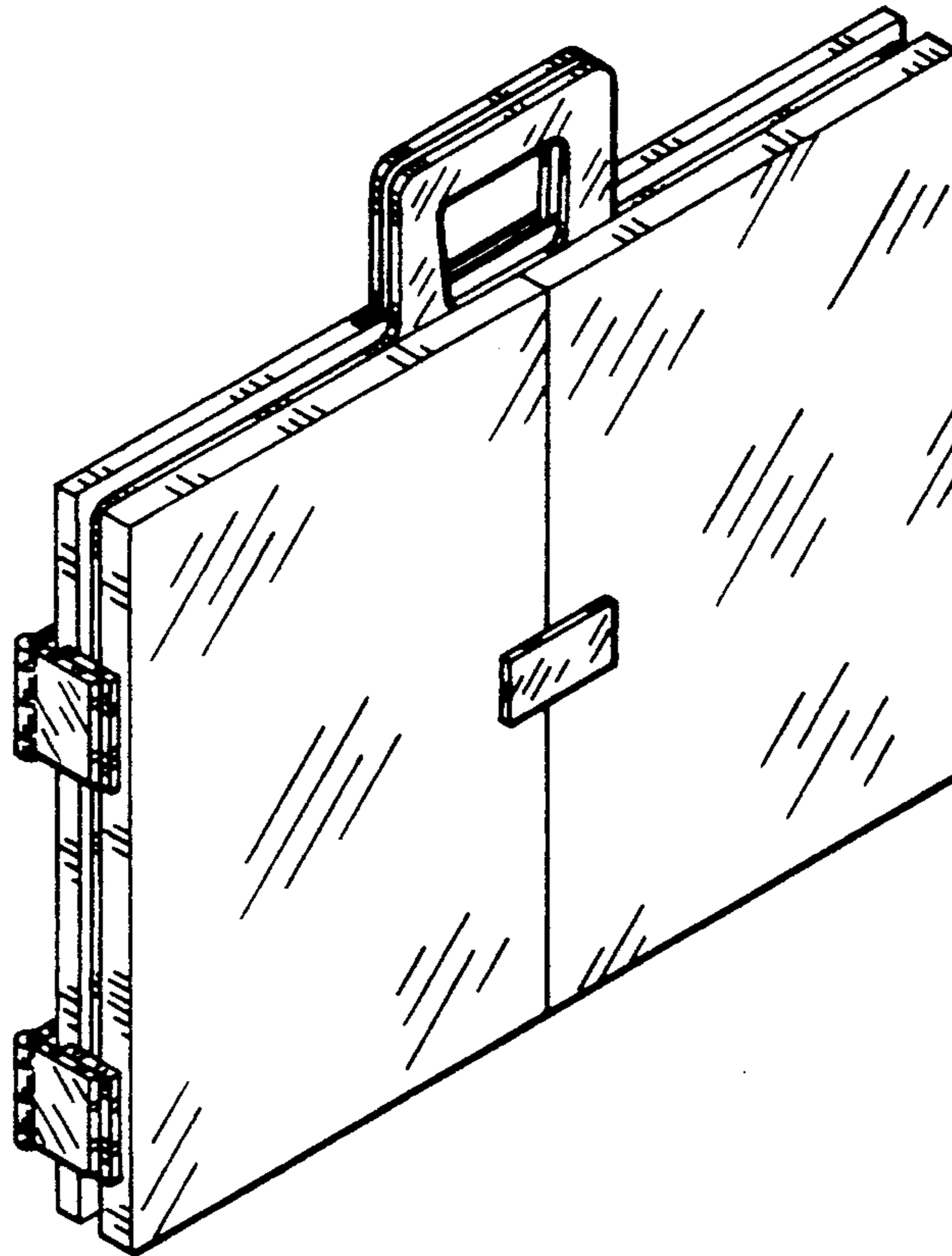

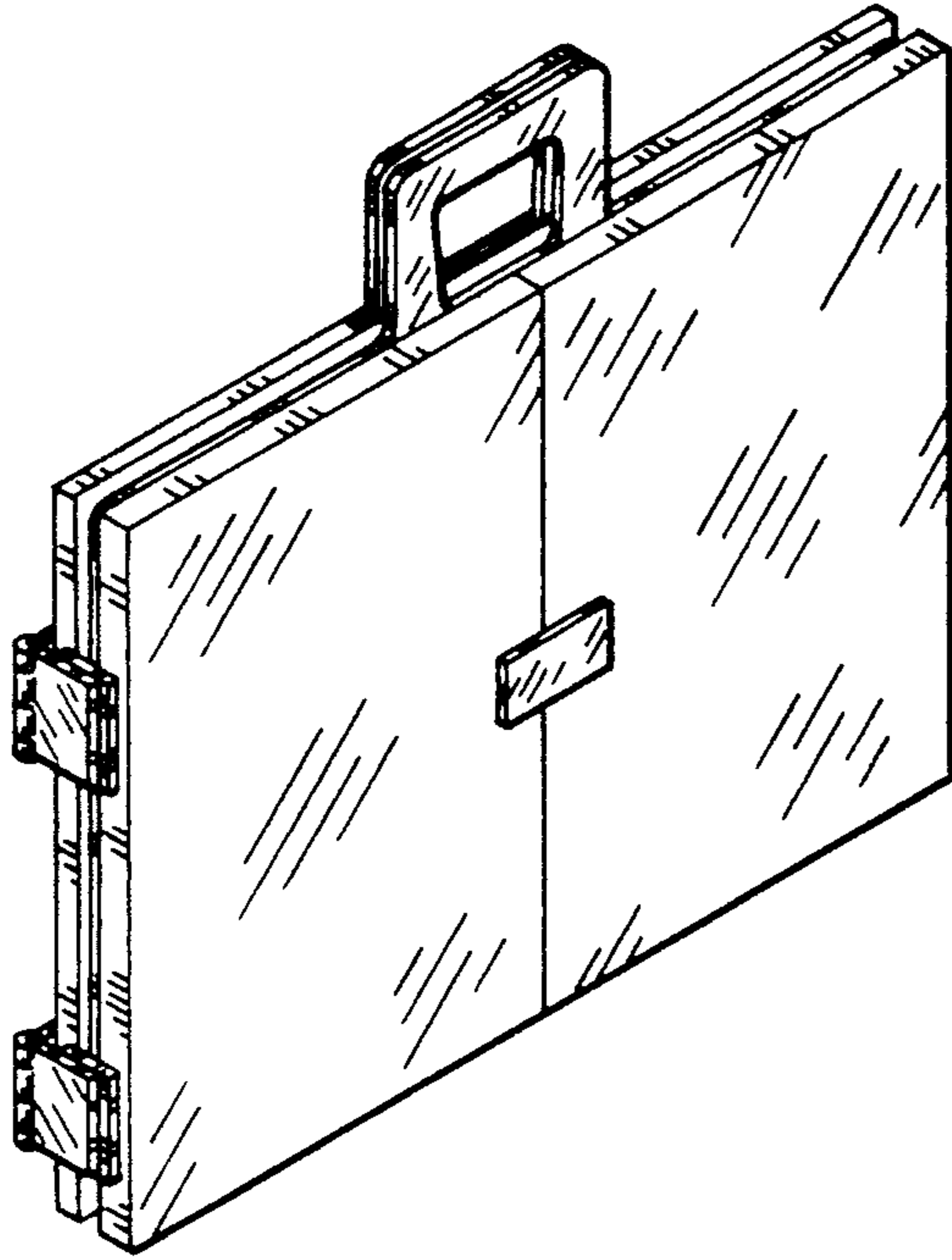

FIG. 1

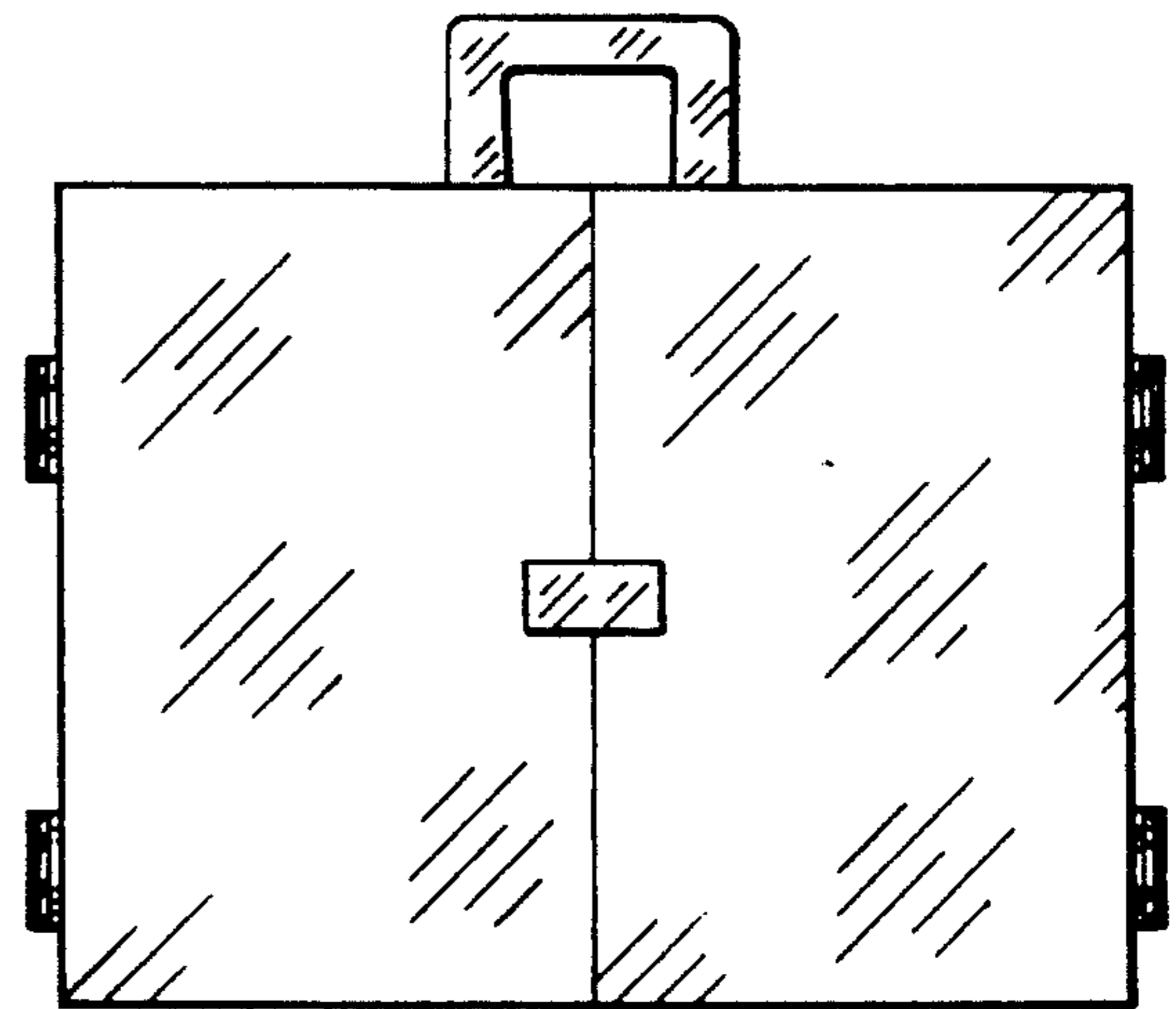

FIG. 2



FIG. 3



FIG. 4

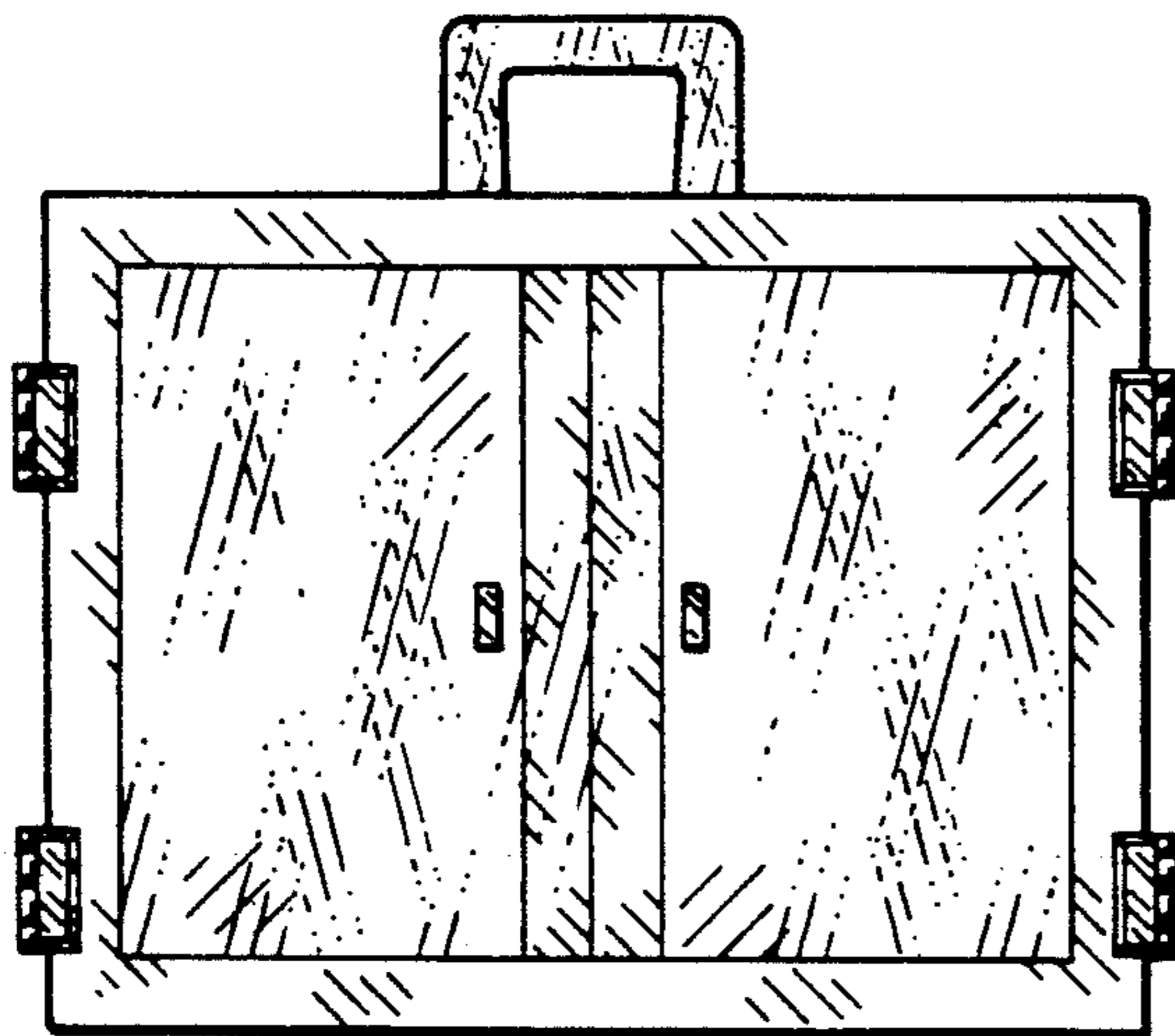

FIG. 5

FIG. 6

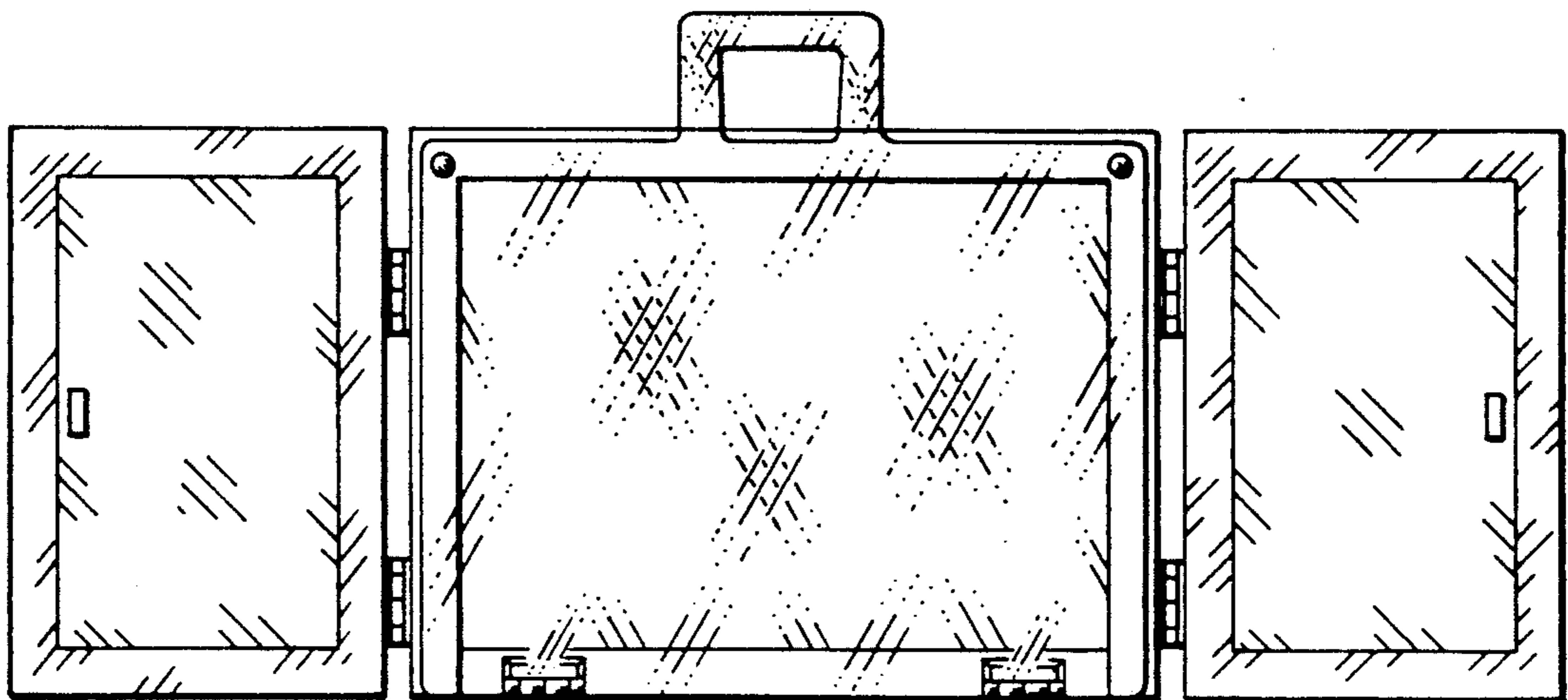

FIG. 7

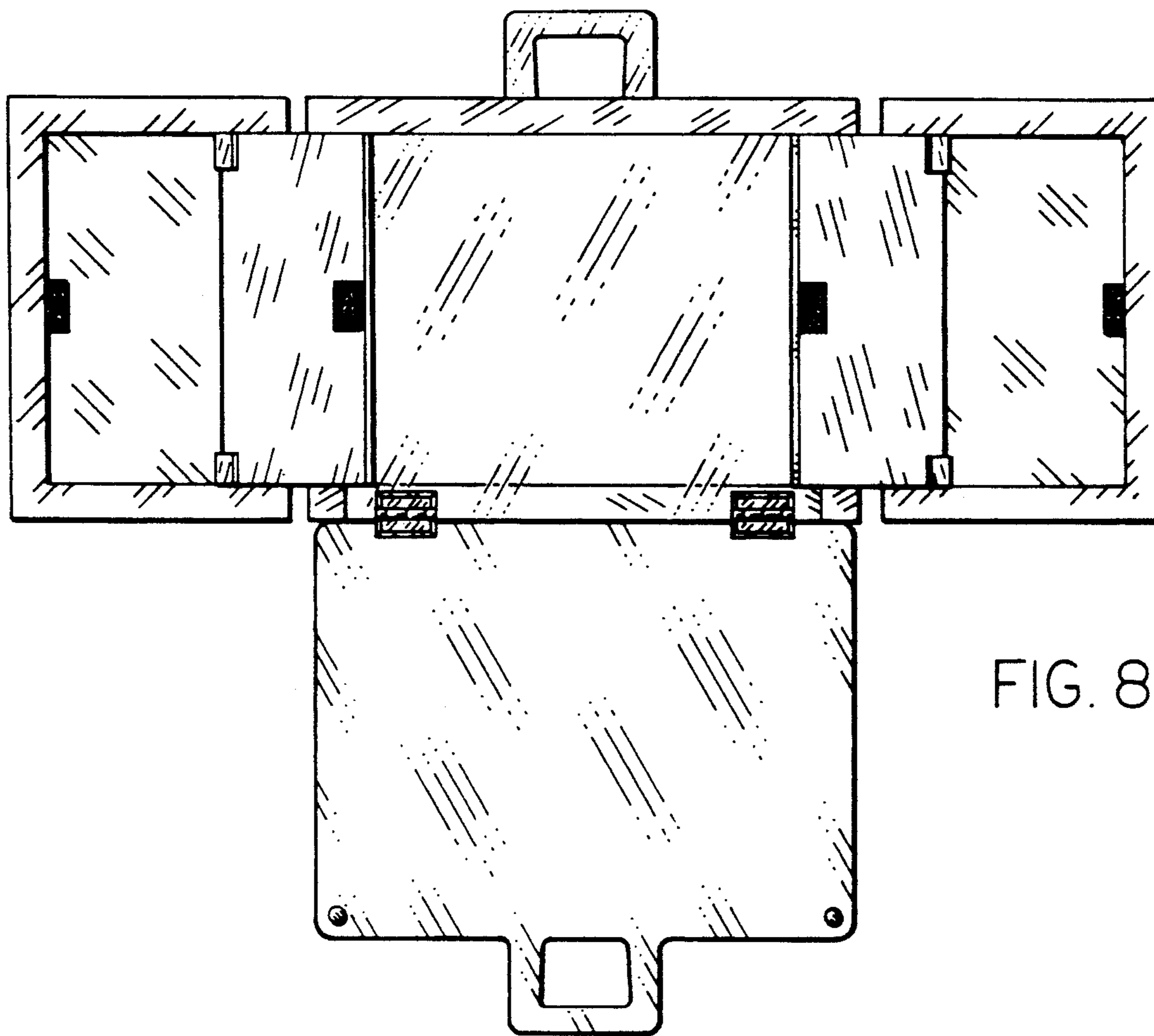

FIG. 8

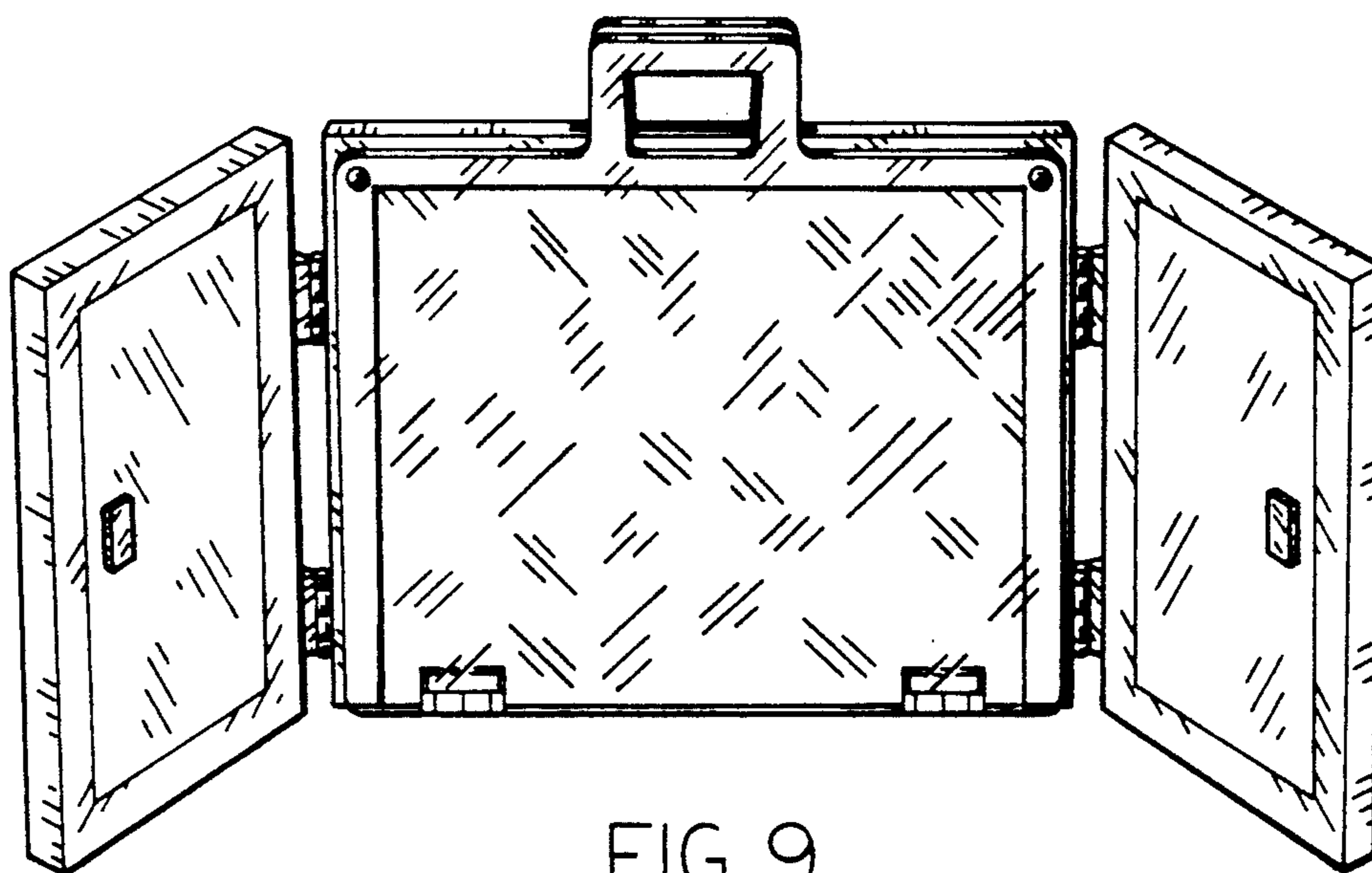

FIG. 9