



US00D332267S

United States Patent [19]

[11] Patent Number: **Des. 332,267**

Iwai

[45] Date of Patent: **** Jan. 5, 1993**

[54] FUEL PUMP

[56] References Cited

[75] Inventor: **Shingo Iwai, Fukuyama, Japan**

U.S. PATENT DOCUMENTS

[73] Assignee: **Mitsubishi Denki Kabushiki Kaisha, Tokyo, Japan**

D. 178,799	9/1956	Lung	D15/7
D. 244,750	6/1977	Roberts et al.	D15/7
4,421,076	12/1983	Sasaki	123/499
4,900,960	2/1990	Becker et al.	74/425

[**] Term: **14 Years**

Primary Examiner—A. Hugo Word
Assistant Examiner—R. Seifert
Attorney, Agent, or Firm—Burns, Doane, Swecker & Mathis

[21] Appl. No.: **424,565**

[57] CLAIM

[22] Filed: **Oct. 20, 1989**

The ornamental design for a fuel pump, as shown and described.

[30] Foreign Application Priority Data

DESCRIPTION

Apr. 22, 1989 [JP] Japan 1-14955
 [52] U.S. Cl. **D15/7**
 [58] Field of Search D15/5, 7, 9.1;
 417/423.15, 323-325, 423.5, 423, 423.14; 92/98
 R; 123/495, 497, 449, 458, 490, 498, 494;
 74/425

FIG. 1 is a perspective view of a fuel pump showing my new design;
FIG. 2 is a front elevational view;
FIG. 3 is a rear elevational view;
FIG. 4 is a top plan view;
FIG. 5 is a bottom plan view;
FIG. 6 is a left side elevational view; and,
FIG. 7 is a right side elevational view.

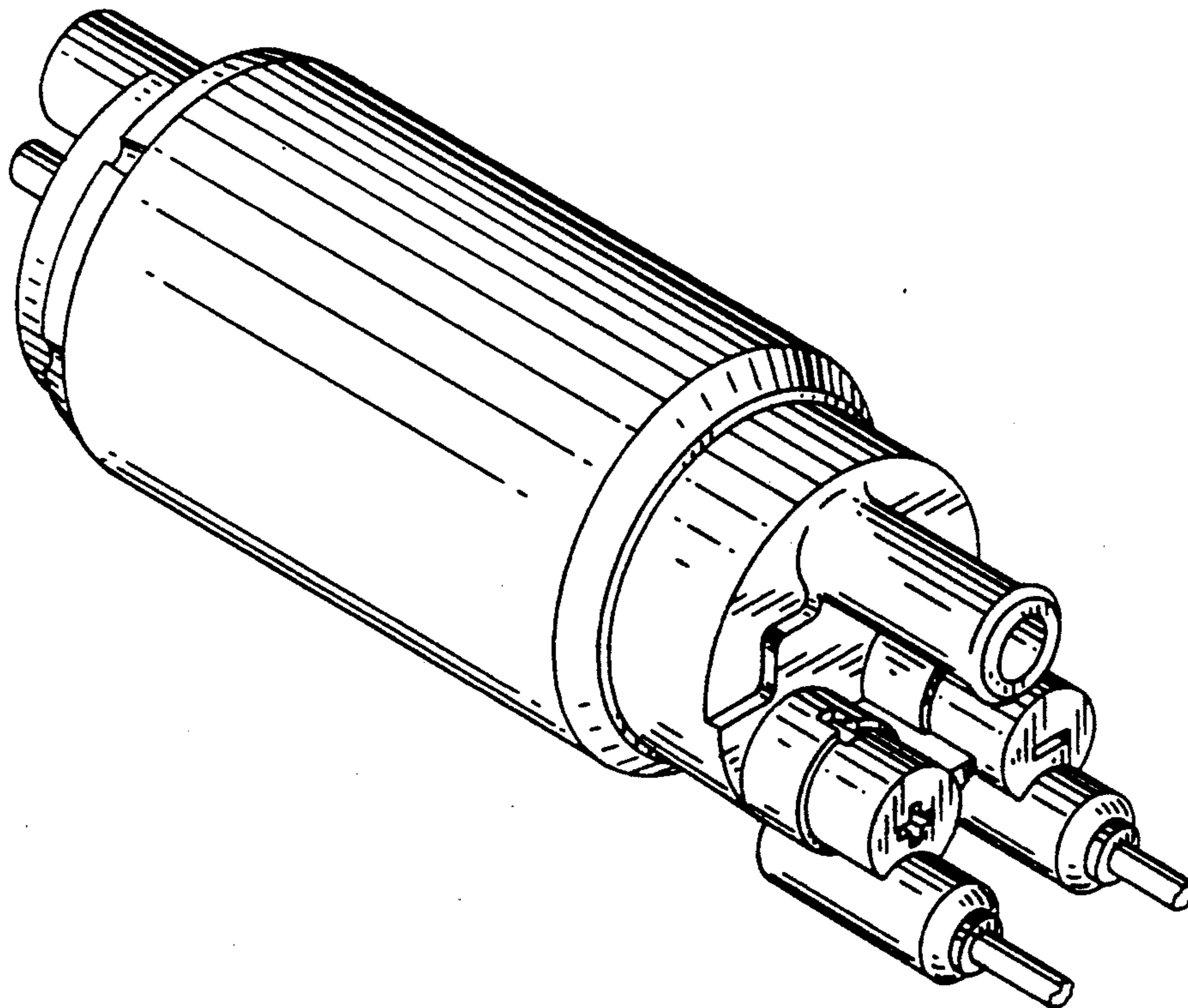

Fig. 1

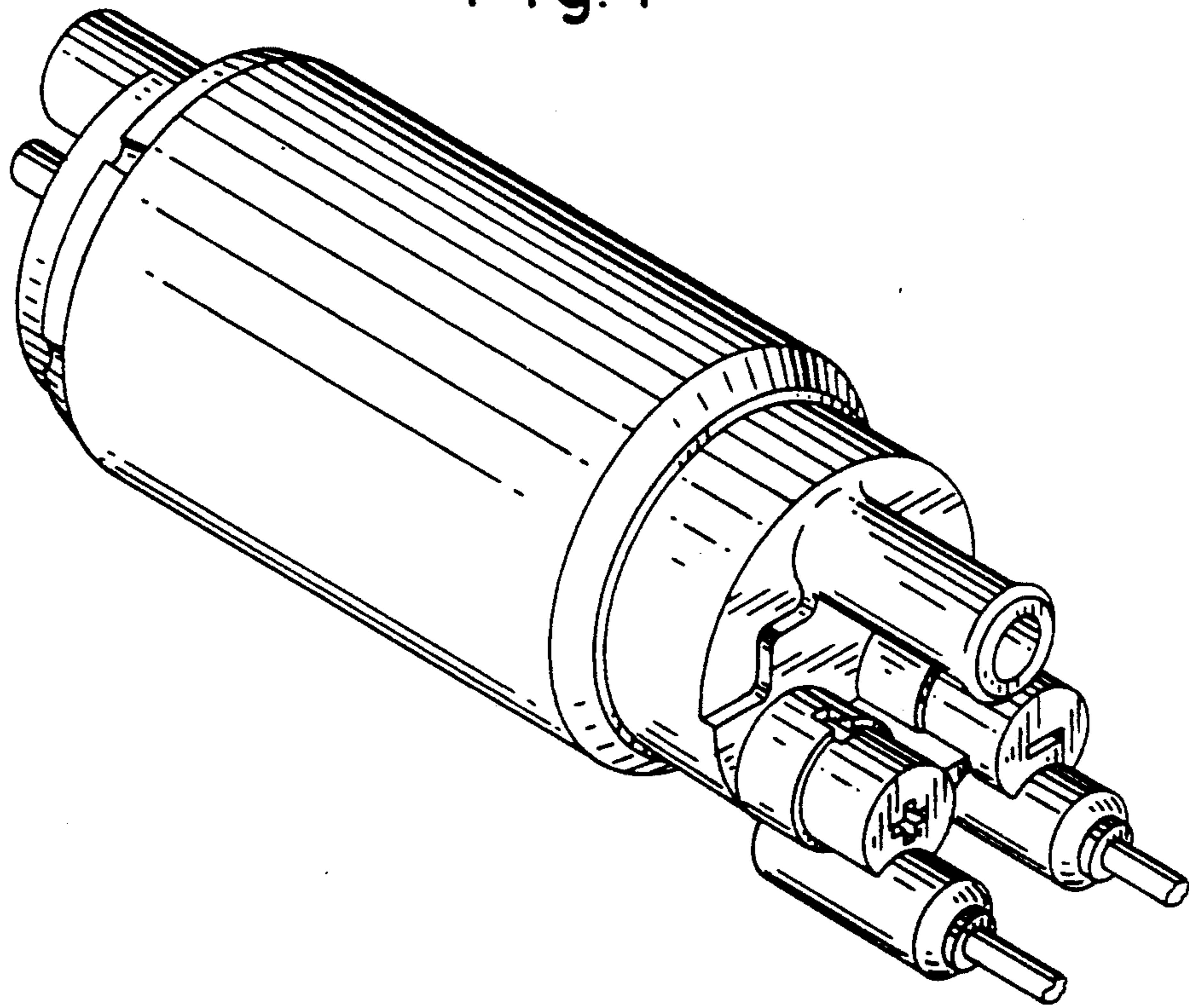

Fig. 2

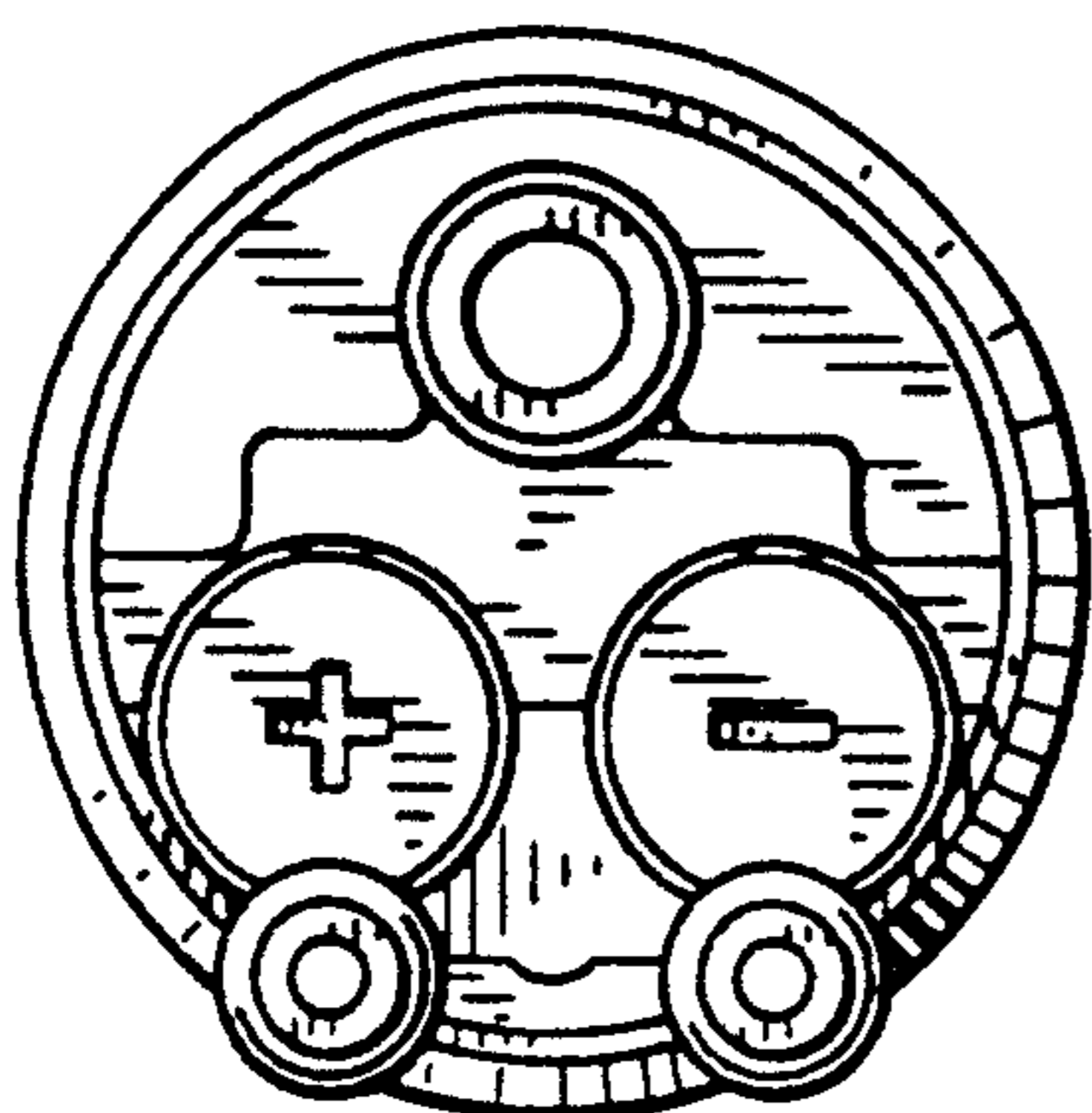

Fig. 3

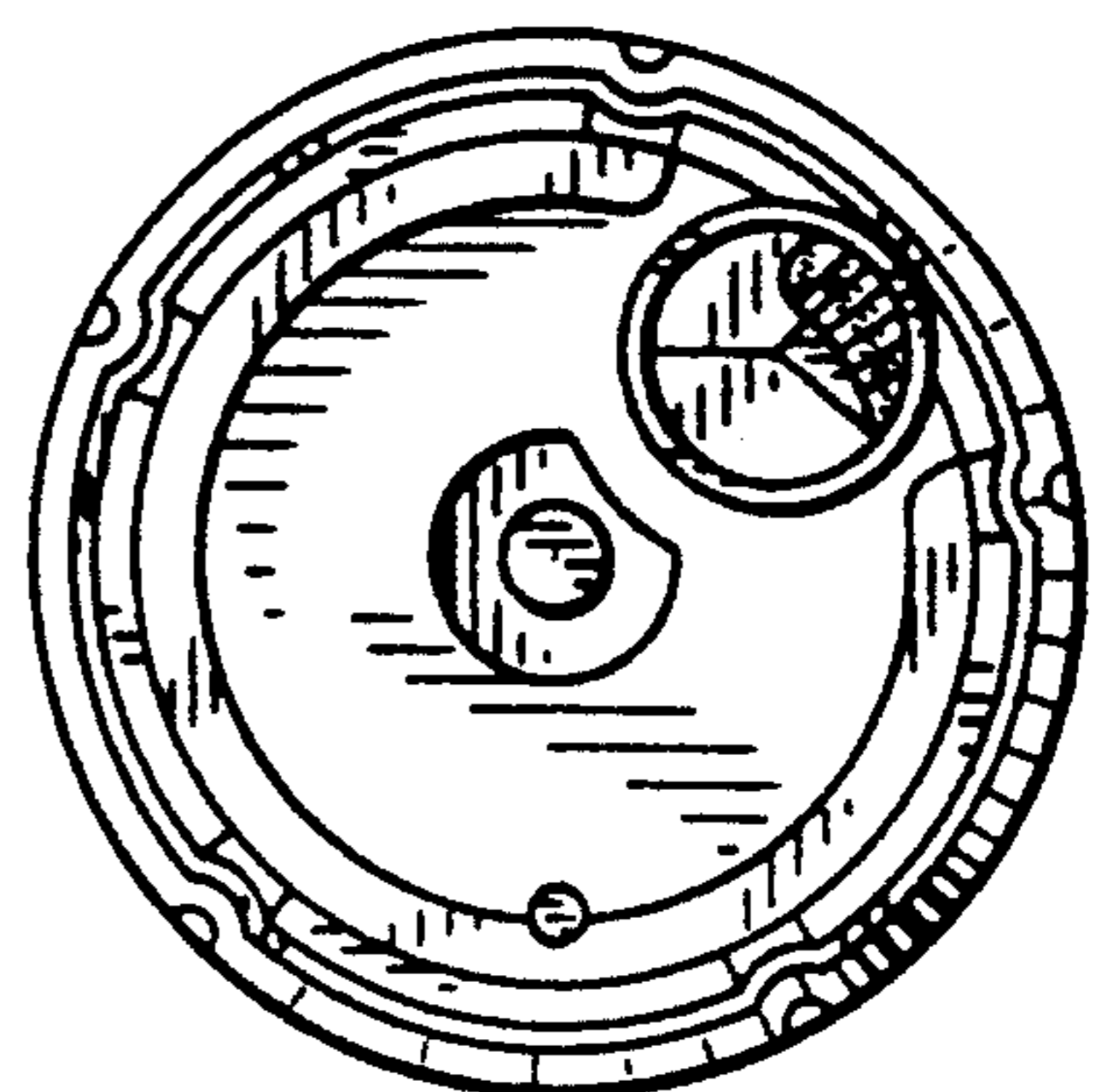

Fig. 4

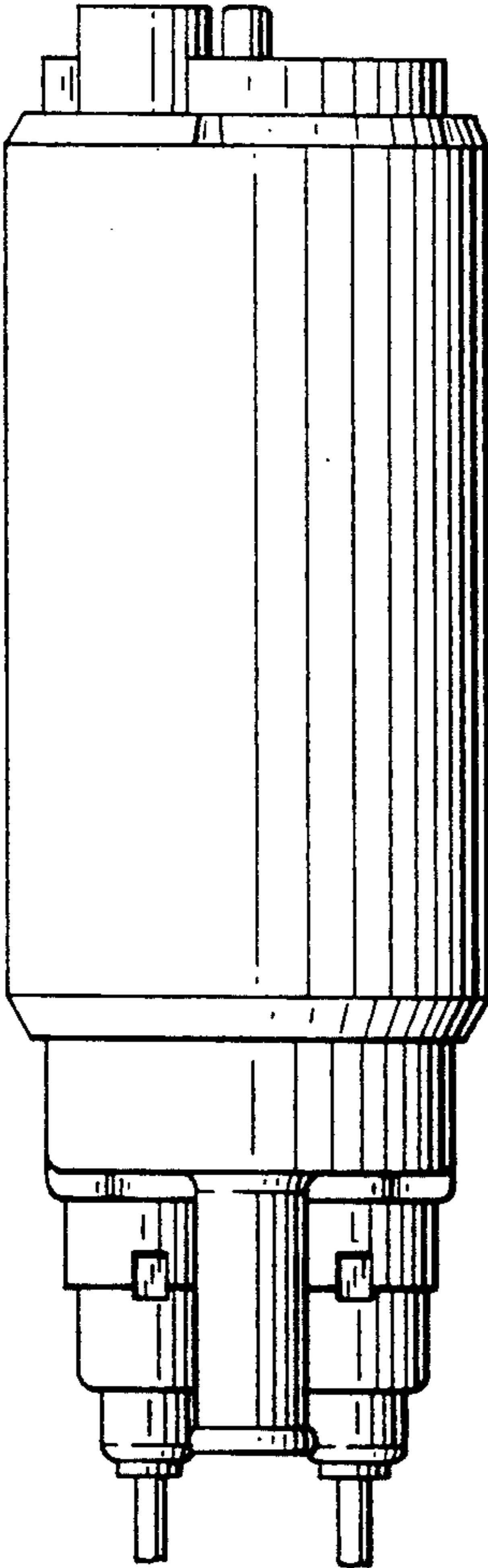

Fig. 5

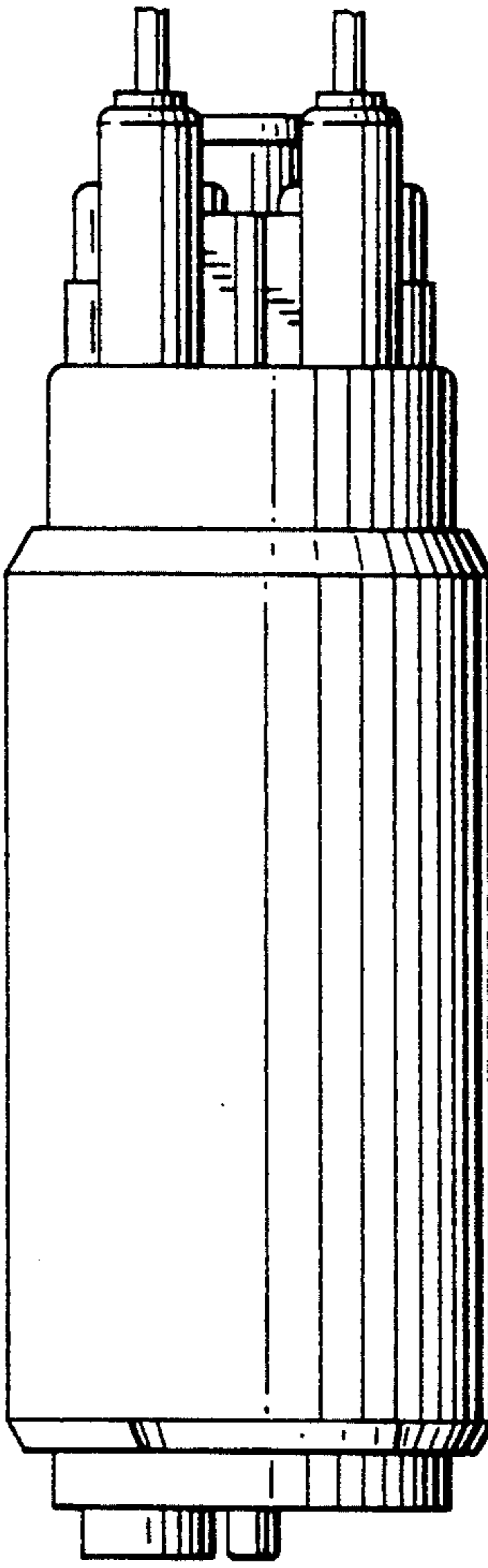

Fig. 6

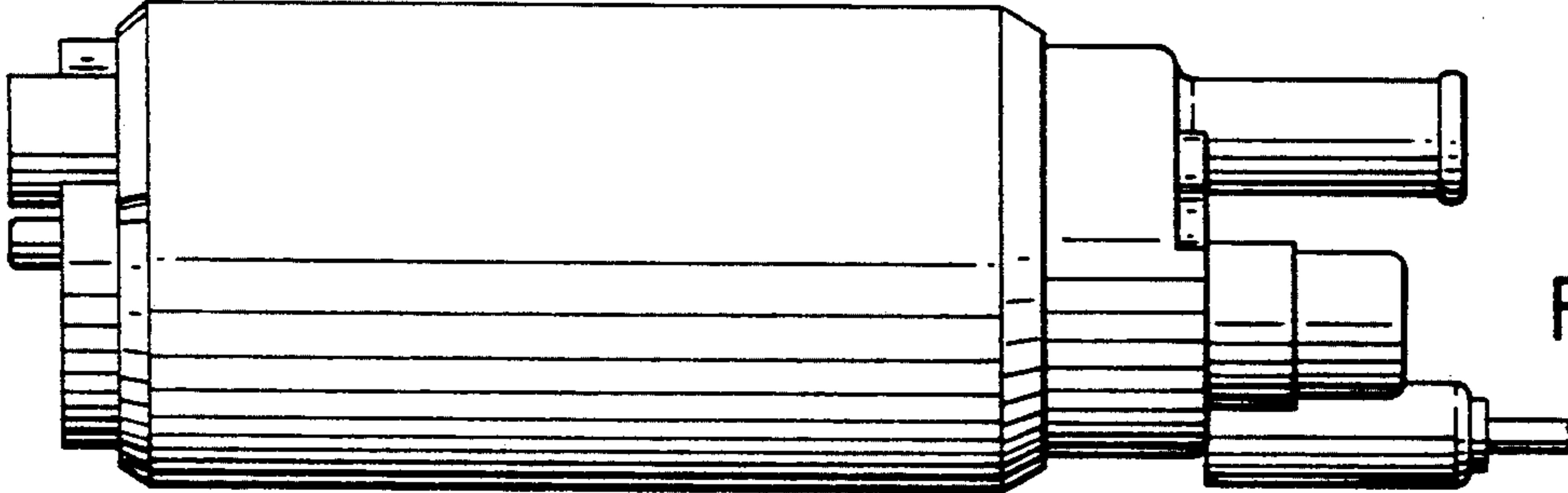

Fig. 7

