



US00D332265S

# United States Patent [19]

[11] Patent Number: **Des. 332,265**

**Osumi**

[45] Date of Patent: **\*\* Jan. 5, 1993**

[54] **OUTBOARD MOTOR**

4,747,795	5/1988	Kawamura et al.	440/900
4,749,374	6/1988	Ferguson	440/900
4,846,300	7/1989	Boda	440/900

[75] Inventor: **Masayuki Osumi, Tokyo, Japan**

[73] Assignee: **Honda Giken Kogyo Kabushiki Kaisha, Tokyo, Japan**

*Primary Examiner*—A. Hugo Word  
*Assistant Examiner*—R. Seifert  
*Attorney, Agent, or Firm*—Schwartz & Weinrieb

[\*\*] Term: **14 Years**

[57] **CLAIM**

[21] Appl. No.: **611,864**

The ornamental design for an outboard motor, as shown and described.

[22] Filed: **Nov. 13, 1990**

[52] U.S. Cl. .... **D15/4**

**DESCRIPTION**

[58] Field of Search ..... **D15/1-4;**  
**440/52-53, 3-4, 6, 900; 290/43, 46, 54; 123/495**

FIG. 1 is a perspective view of an outboard motor showing my new design;

[56] **References Cited**

**U.S. PATENT DOCUMENTS**

D. 272,358	1/1984	Hall et al.	D15/4
3,211,119	10/1965	Kiekhaefer	440/900
3,703,642	11/1972	Balaguer	440/3
4,354,847	10/1982	Blanchard	440/900

FIG. 2 is a front elevational view thereof;

FIG. 3 is a rear elevational view thereof;

FIG. 4 is a side elevational view thereof;

FIG. 5 is a side elevational view thereof, of the opposite side of FIG. 4;

FIG. 6 is a top plan view thereof;

FIG. 7 is a bottom plan view thereof.

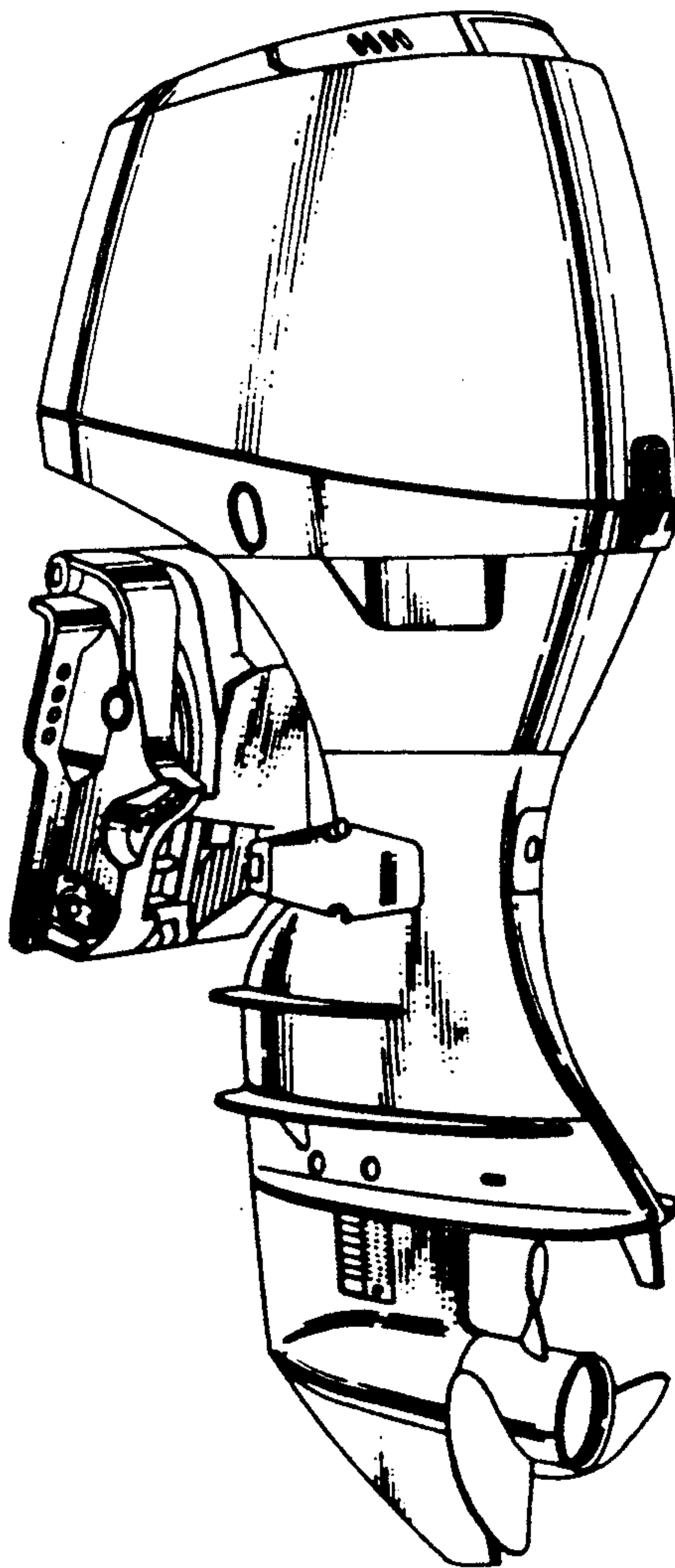

FIG. 1

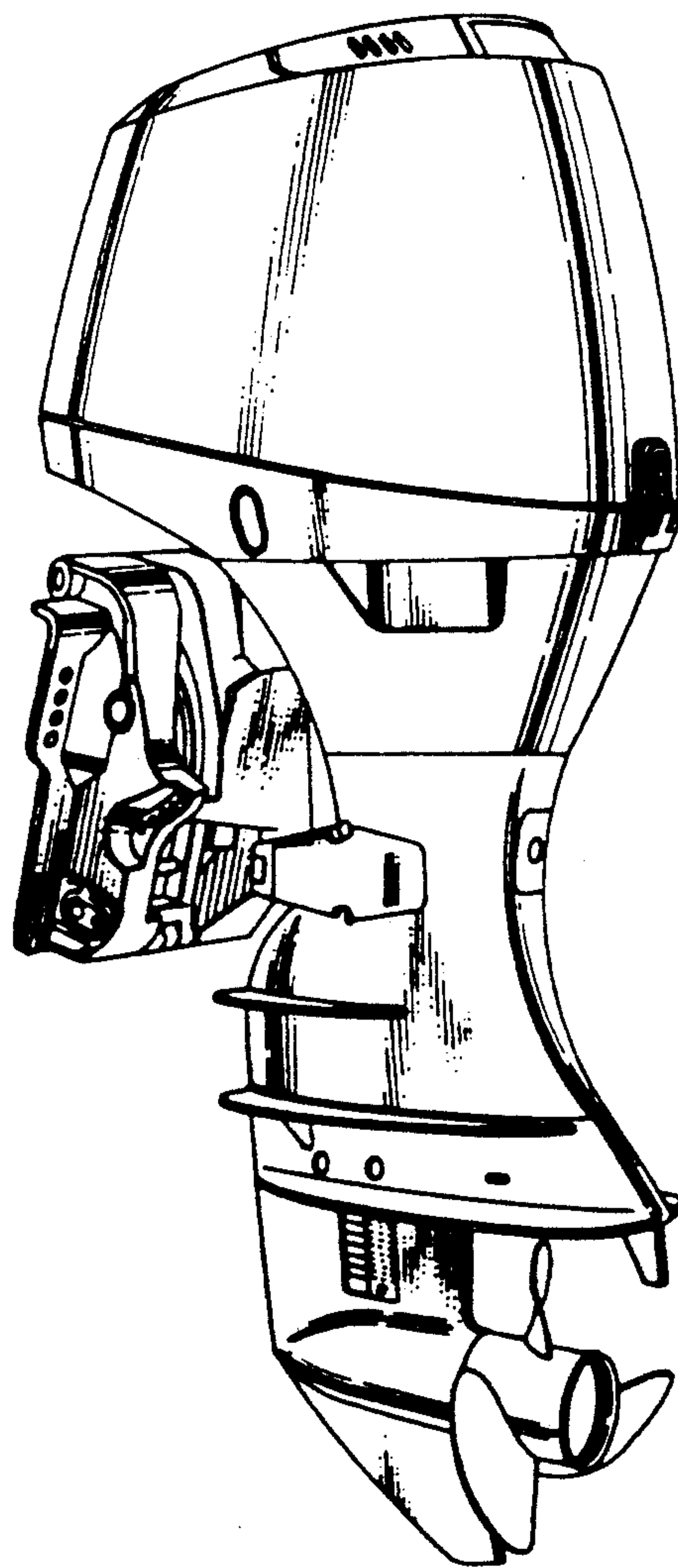

FIG. 3

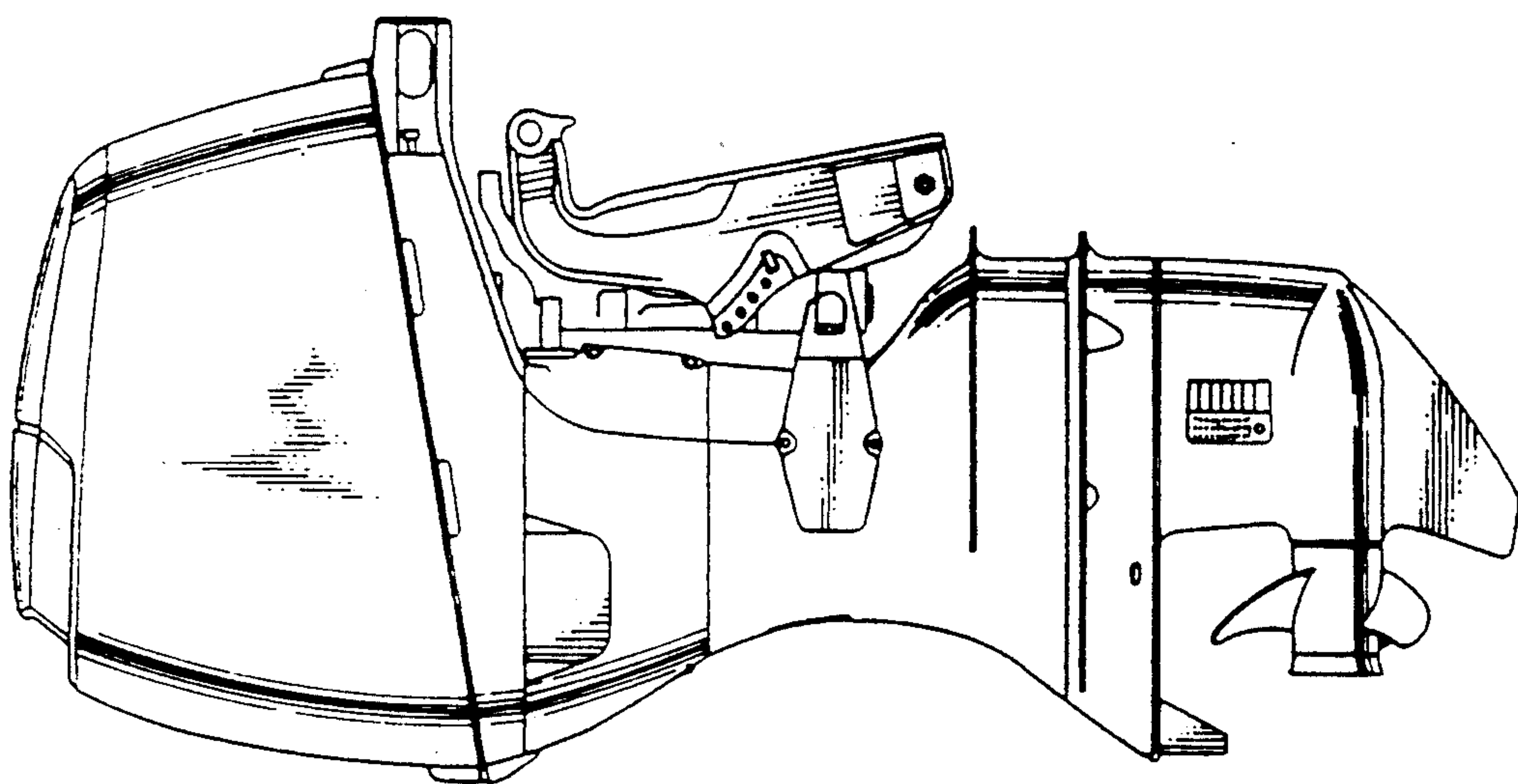

FIG. 2

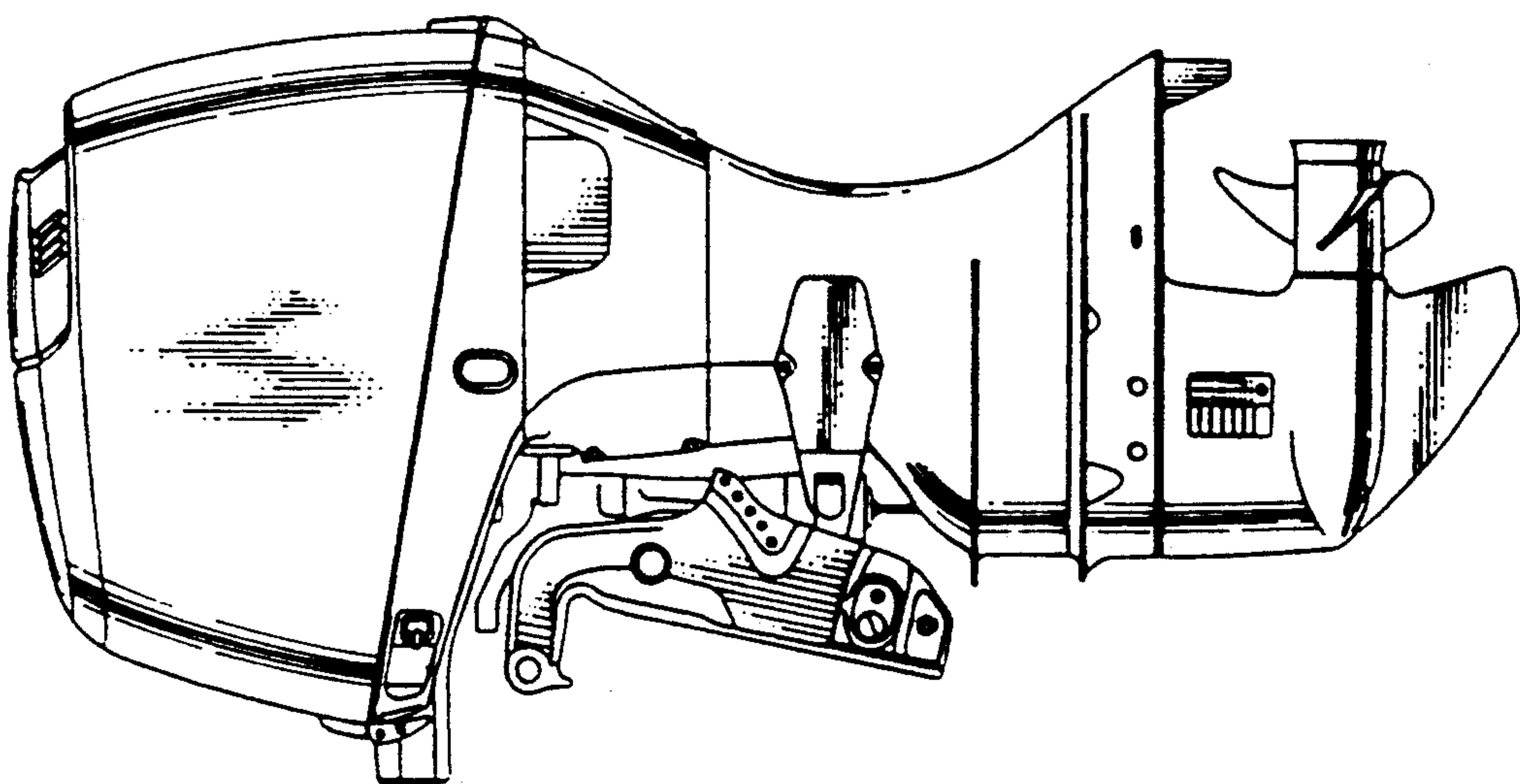

FIG. 4

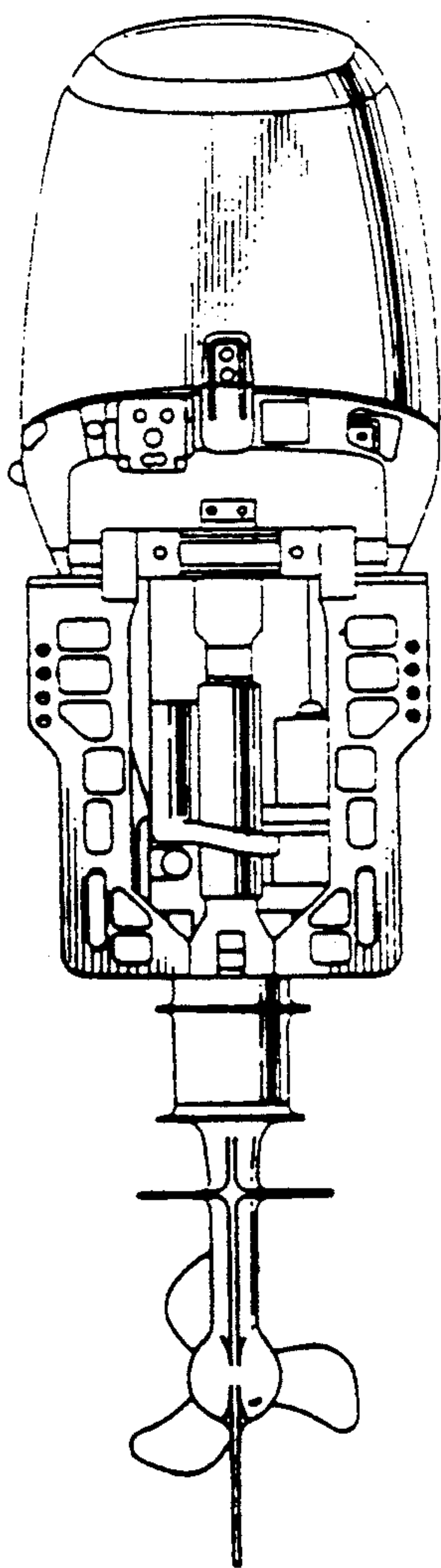
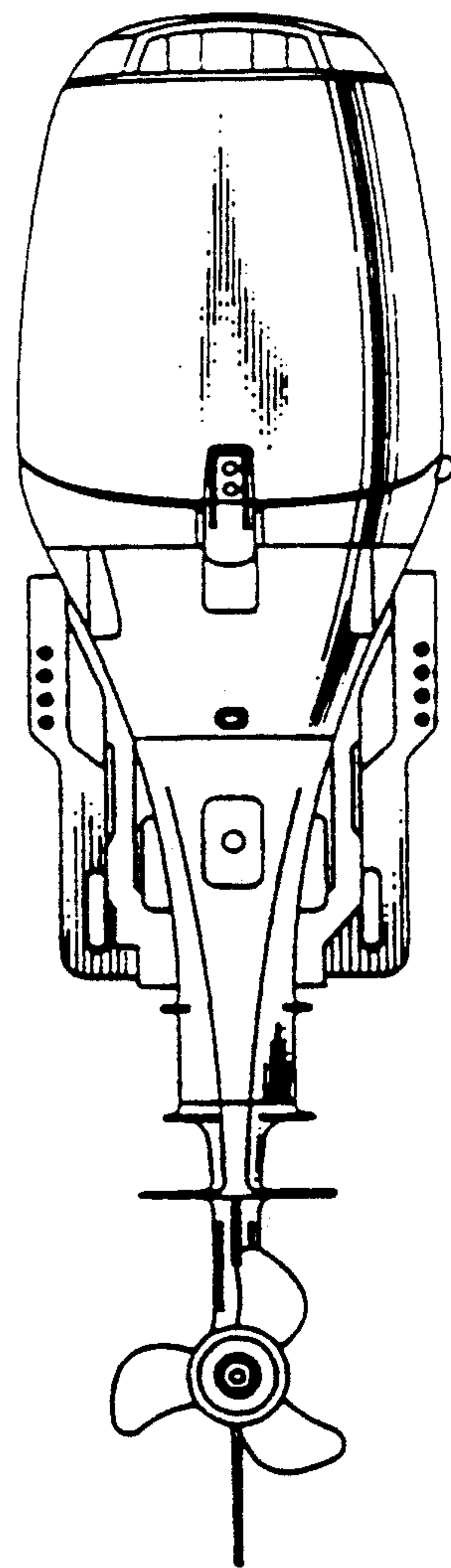
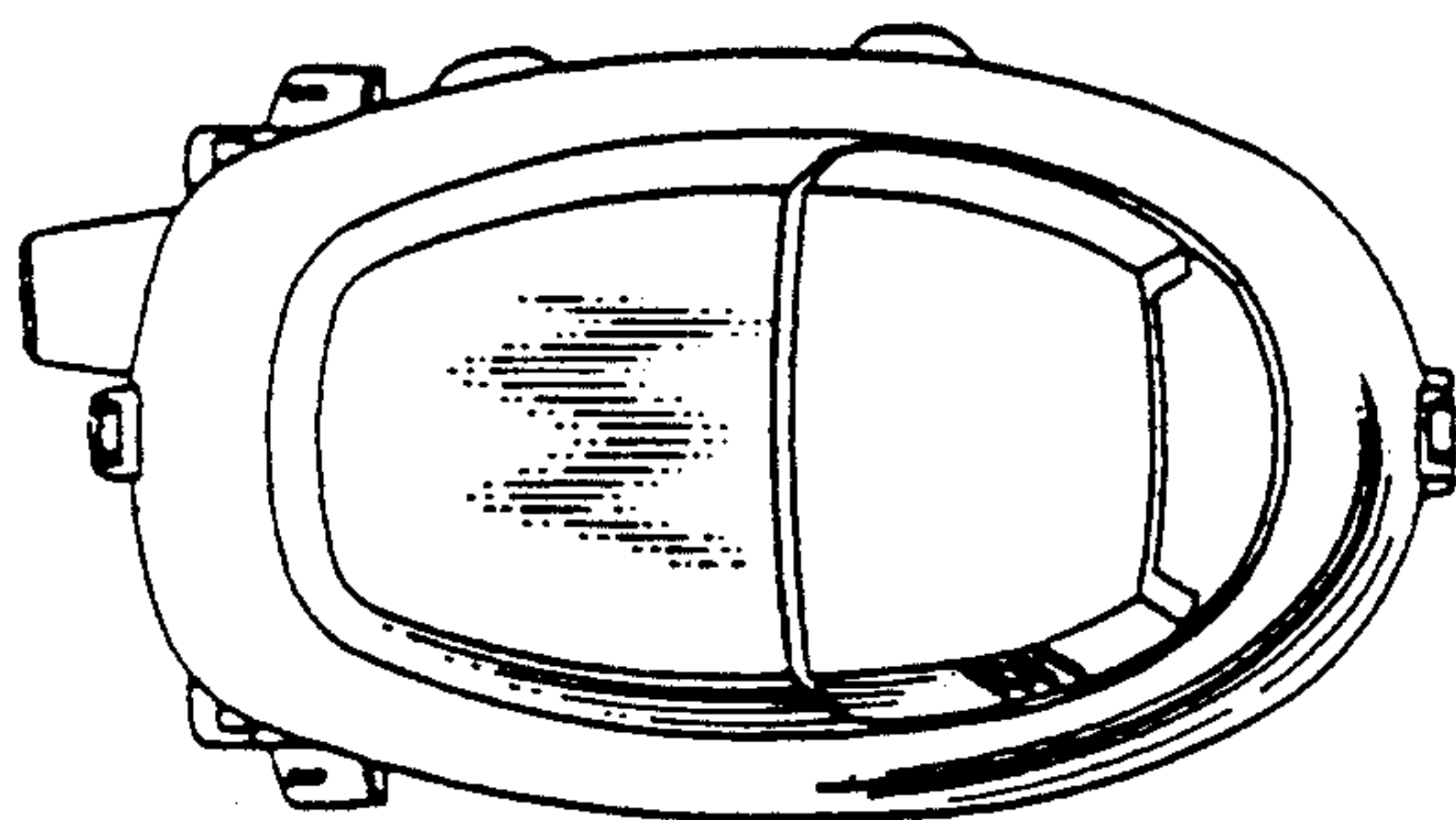

FIG. 5



*FIG. 6*



*FIG. 7*

