



US00D332264S

United States Patent [19]

Pellegrino

[11] Patent Number: Des. 332,264

[45] Date of Patent: ** Jan. 5, 1993

[54] OUTBOARD MOTOR MOUNTING BRACKET

[76] Inventor: Vincent Pellegrino, 1526 E. 5th St., Brooklyn, N.Y. 11230

[**] Term: 14 Years

[21] Appl. No.: 490,252

[22] Filed: Mar. 8, 1990

[52] U.S. Cl. D15/4

[58] Field of Search D12/317; D15/4, 5; 440/3-4, 6-7, 53, 55, 58-60, 64; 248/640, 641, 643, 352; 290/42, 46, 54

[56] References Cited

U.S. PATENT DOCUMENTS

D. 199,377	8/1964	Lisk	D15/4
D. 278,622	4/1985	Honnell	D15/4
D. 286,157	10/1986	Mikado et al.	D15/4
D. 289,296	4/1987	Mahoney	D15/4
D. 308,850	6/1990	McGuire	D15/4
D. 318,474	7/1991	Reynolds	D15/4

4,331,430 5/1982 Lutzke et al. 440/55

OTHER PUBLICATIONS

Military & Navel Recognition Book—Bunkley—Dec. 2, 1941, upper left of page 113.

Primary Examiner—A. Hugo Word

Assistant Examiner—R. Seifert

Attorney, Agent, or Firm—Terry M. Gernstein

[57] CLAIM

The ornamental design for an outboard motor mounting bracket, as shown and described.

DESCRIPTION

FIG. 1 is a perspective view of an outboard motor mounting bracket showing my new design; FIG. 2 is a front elevational view; FIG. 3 is a top plan view; FIG. 4 is a bottom plan view; FIG. 5 is a rear elevational view; and, FIG. 6 is a side elevational view, the opposite side being a mirror image.

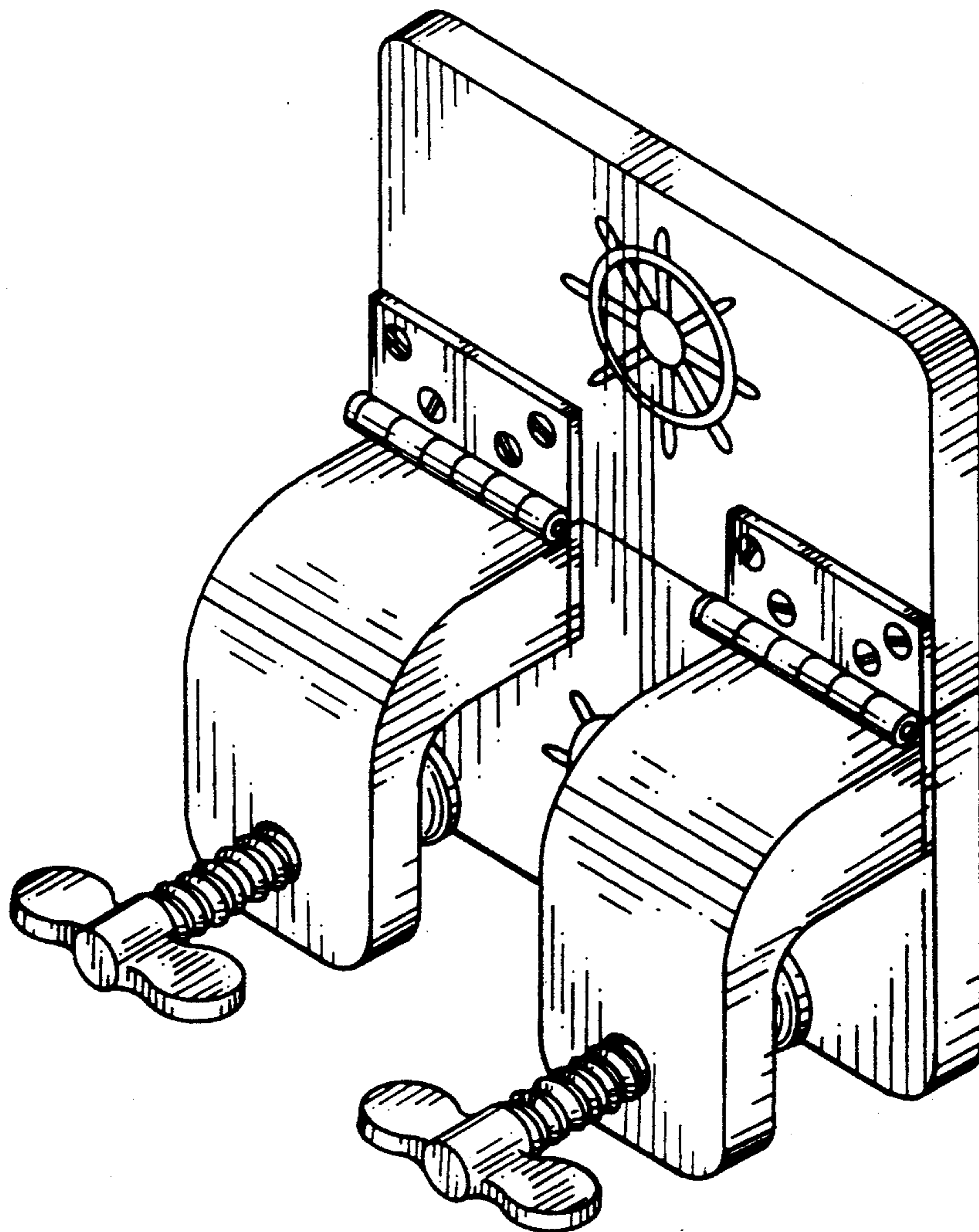

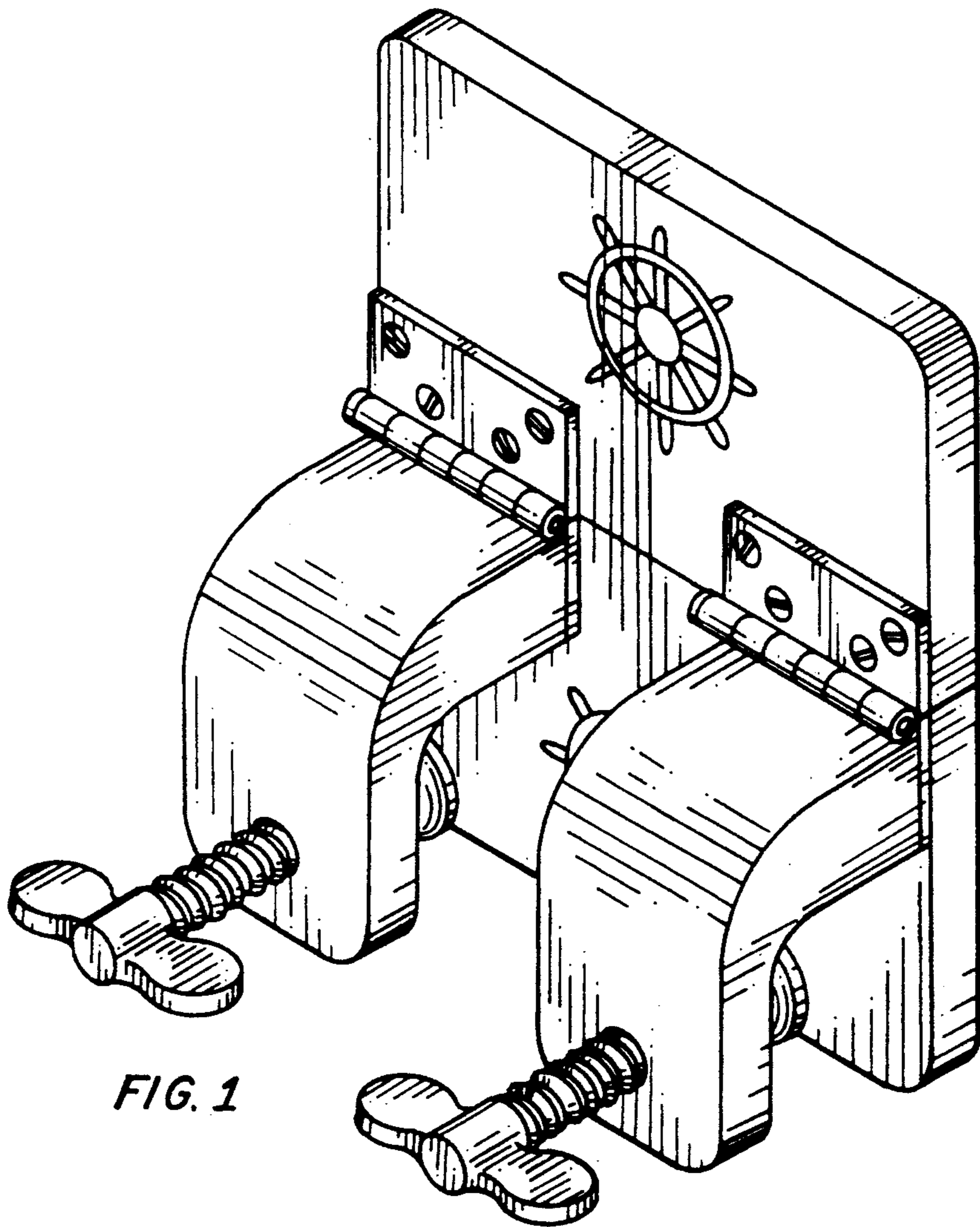

FIG. 1

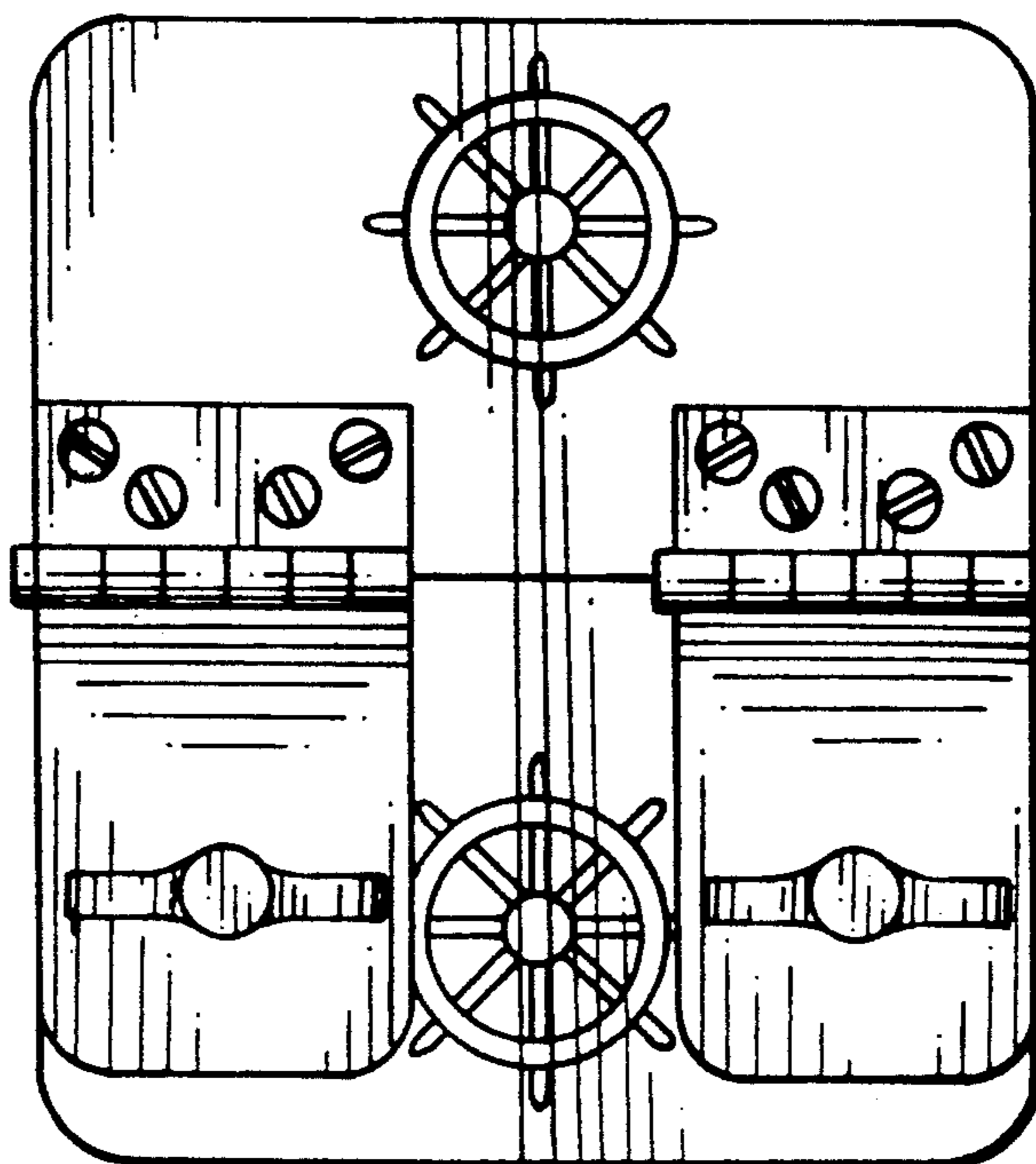

FIG. 2

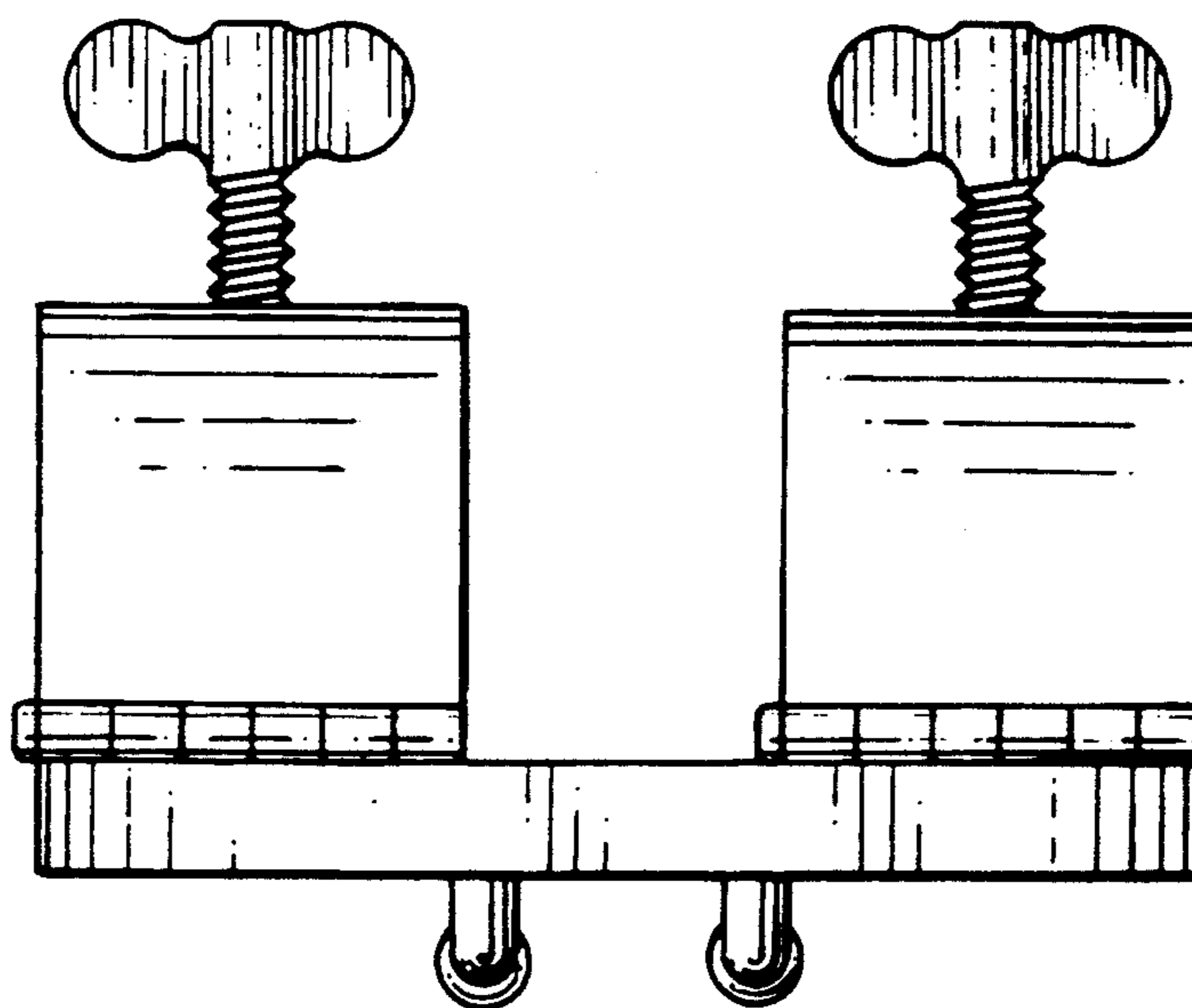

FIG. 3

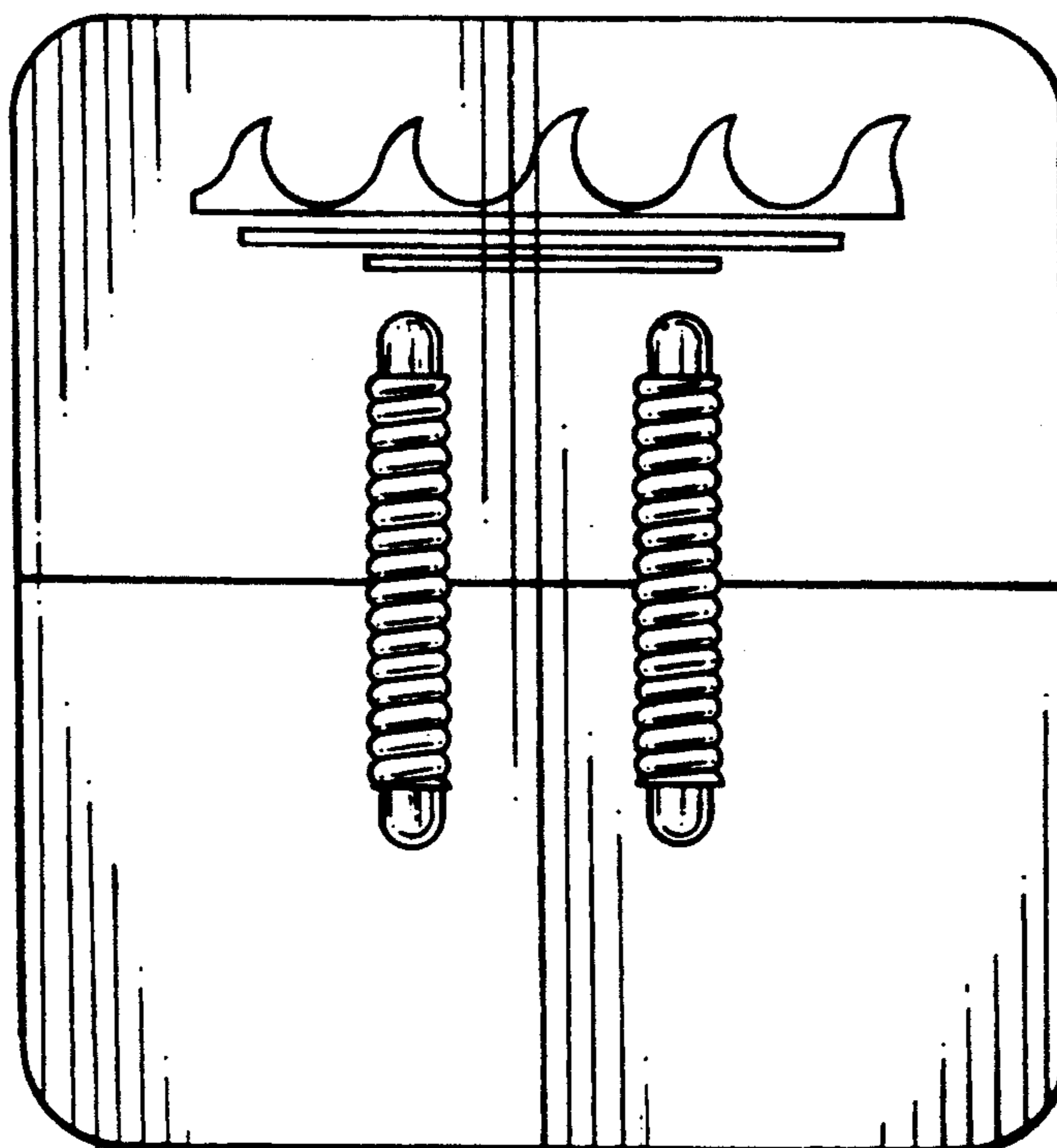

FIG. 5

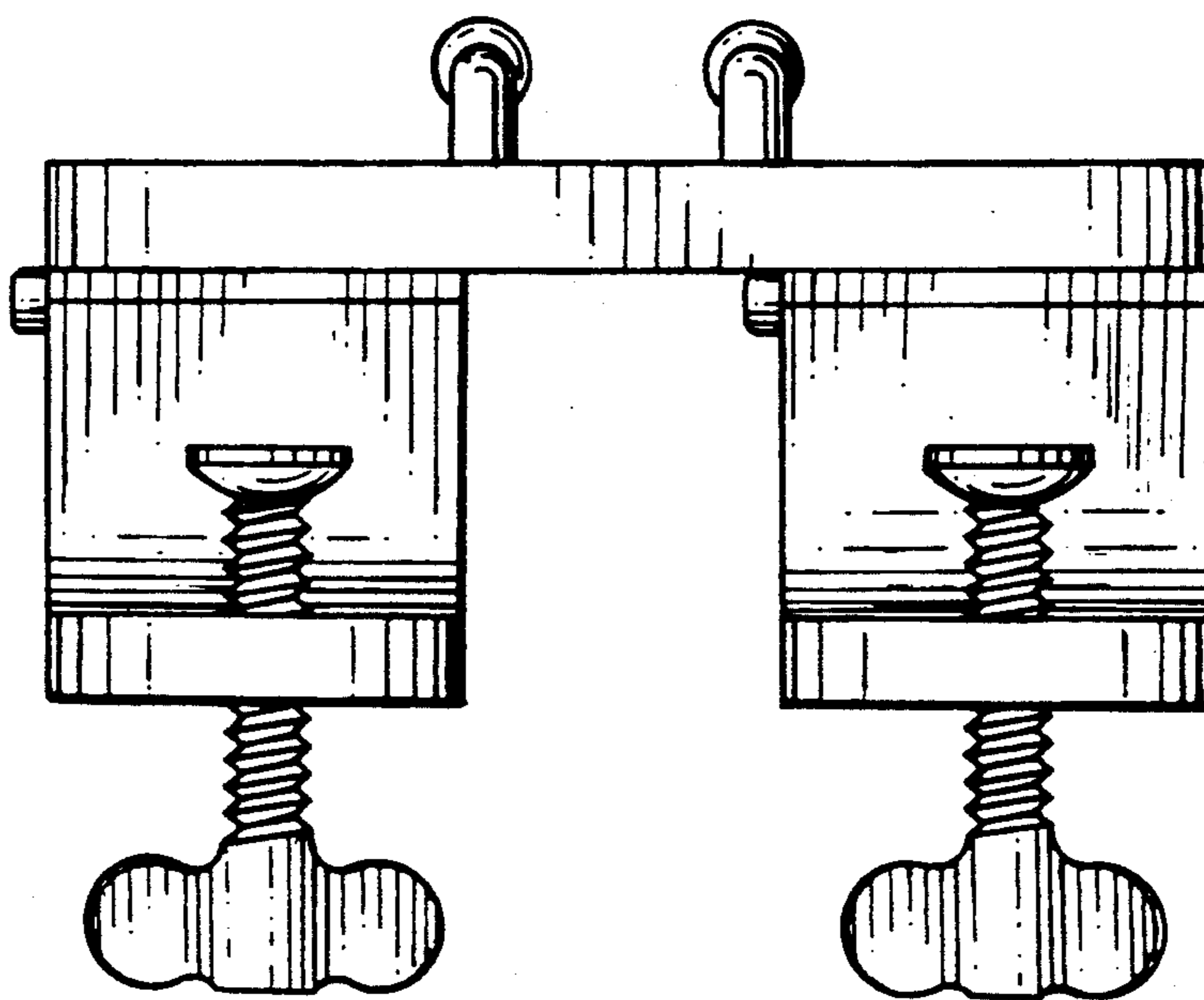

FIG. 4

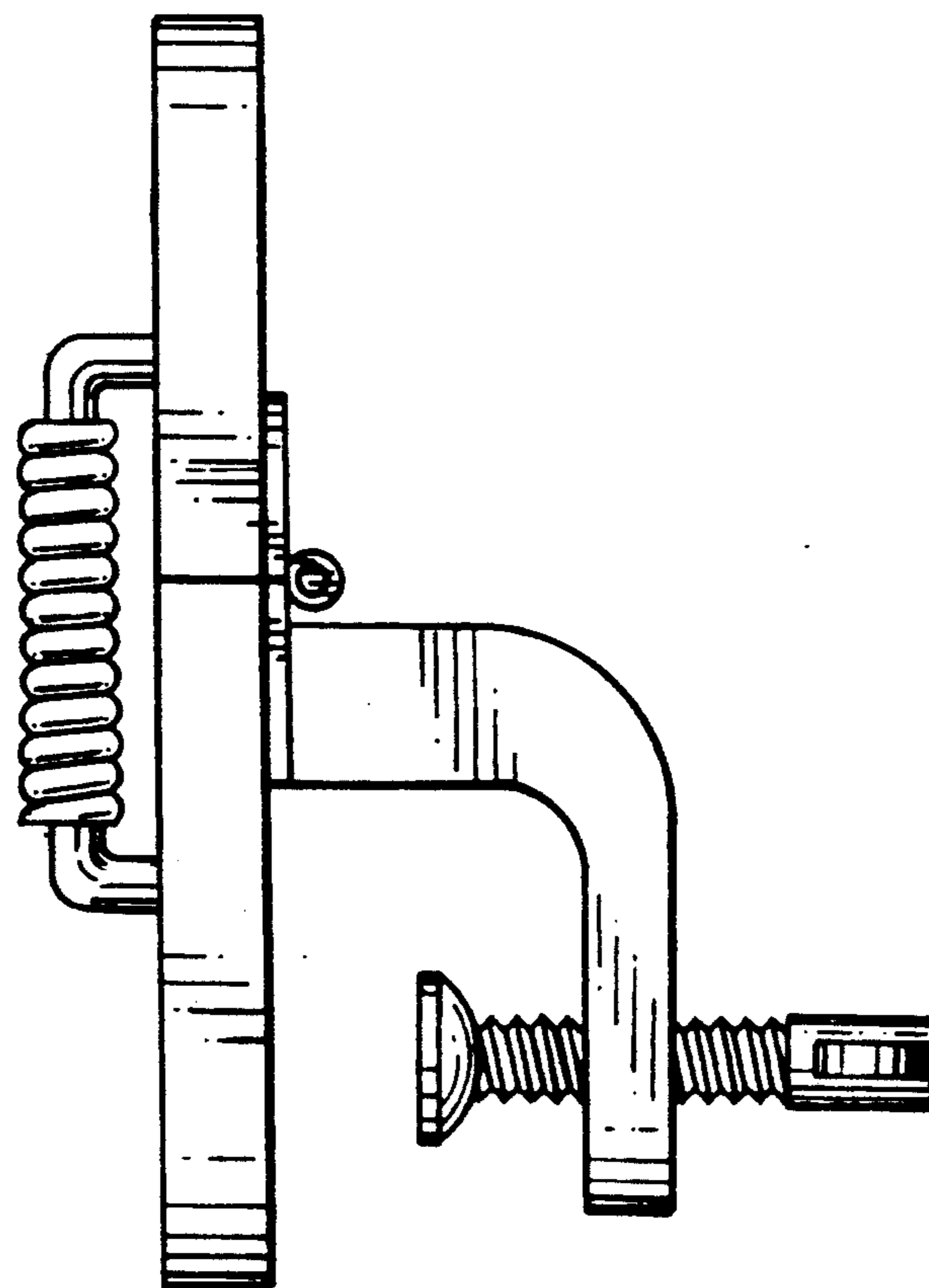

FIG. 6