



US00D332079S

United States Patent [19]

[11] Patent Number: **Des. 332,079**

Haga et al.

[45] Date of Patent: **** Dec. 29, 1992**

[54] **DUAL MODE AIRCRAFT**

[75] Inventors: **Cecil W. Haga**, Arlington, Tex.;
Taiichi Ishida, Nagoya, Japan

[73] Assignee: **The Ishida Foundation**, Nagoya,
Japan

[**] Term: **14 Years**

[21] Appl. No.: **772,040**

[22] Filed: **Oct. 7, 1991**

[52] U.S. Cl. **D12/331; D12/337**

[58] Field of Search **D12/319, 328, 331, 334,**
D12/335; 244/45 R, 45 A, 55, 13, 91, 199

[56] **References Cited**

U.S. PATENT DOCUMENTS

D. 203,720	2/1966	Jarchow	D12/335
D. 311,719	10/1990	Haga	D12/328
D. 317,287	6/1991	Haga	D12/344
D. 323,315	1/1992	Haga	D12/331

Primary Examiner—Kay H. Chin
Attorney, Agent, or Firm—Sughrue, Mion, Zinn,
Macpeak & Seas

[57] **CLAIM**

The ornamental design for a dual mode aircraft, as shown and described.

DESCRIPTION

FIG. 1 is a front, top and right side perspective view of a dual mode aircraft showing our new design; FIG. 2 is a rear, top and right side perspective view thereof; FIG. 3 is a front elevational view thereof; FIG. 4 is a rear elevational view thereof; FIG. 5 is a top plan view thereof; FIG. 6 is a bottom plan view thereof; FIG. 7 is a right side elevational view thereof; FIG. 8 is a left side elevational view thereof; and, FIG. 9 is a front, top and right side perspective view thereof with the wings rotated 90° into a vertically upright position.

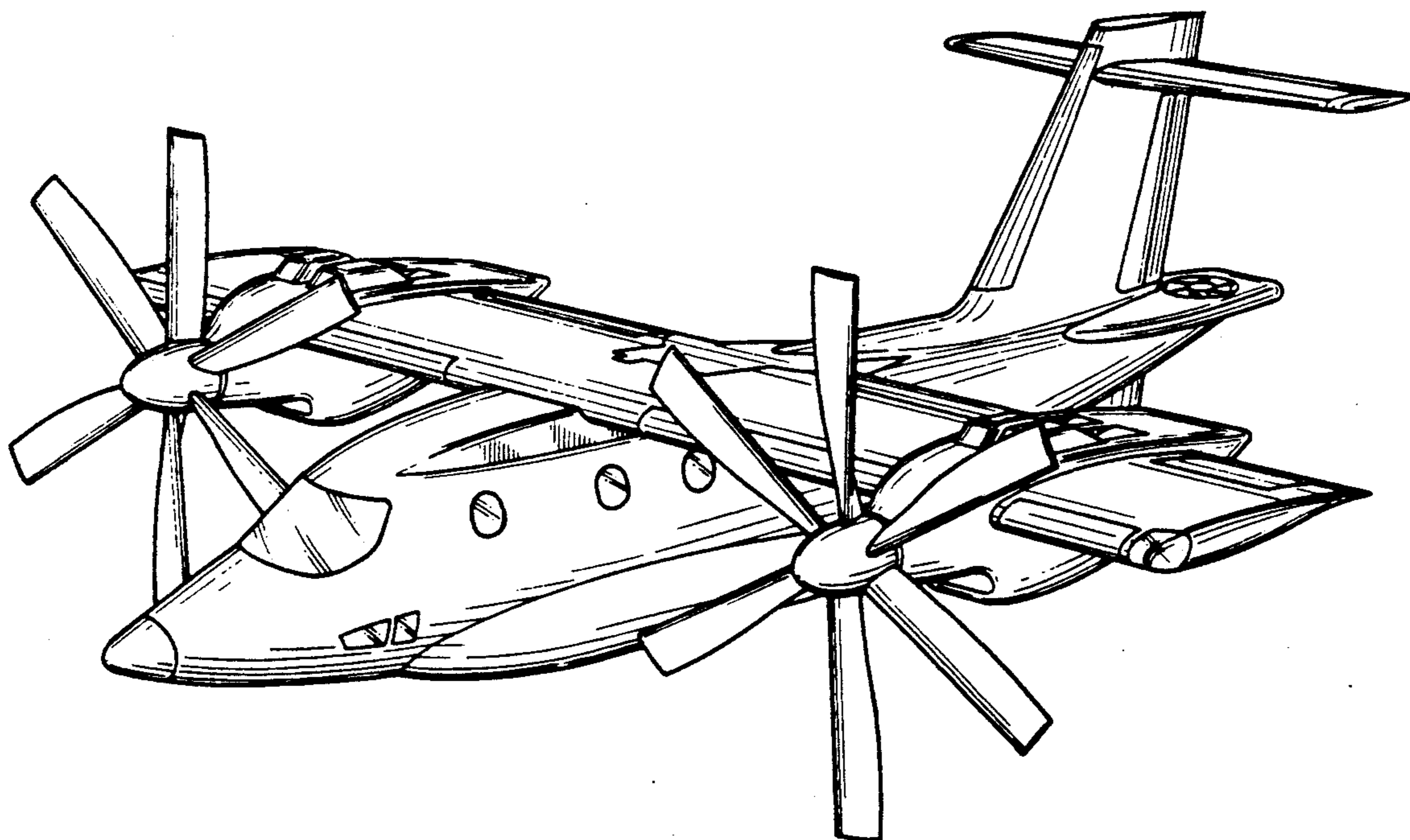

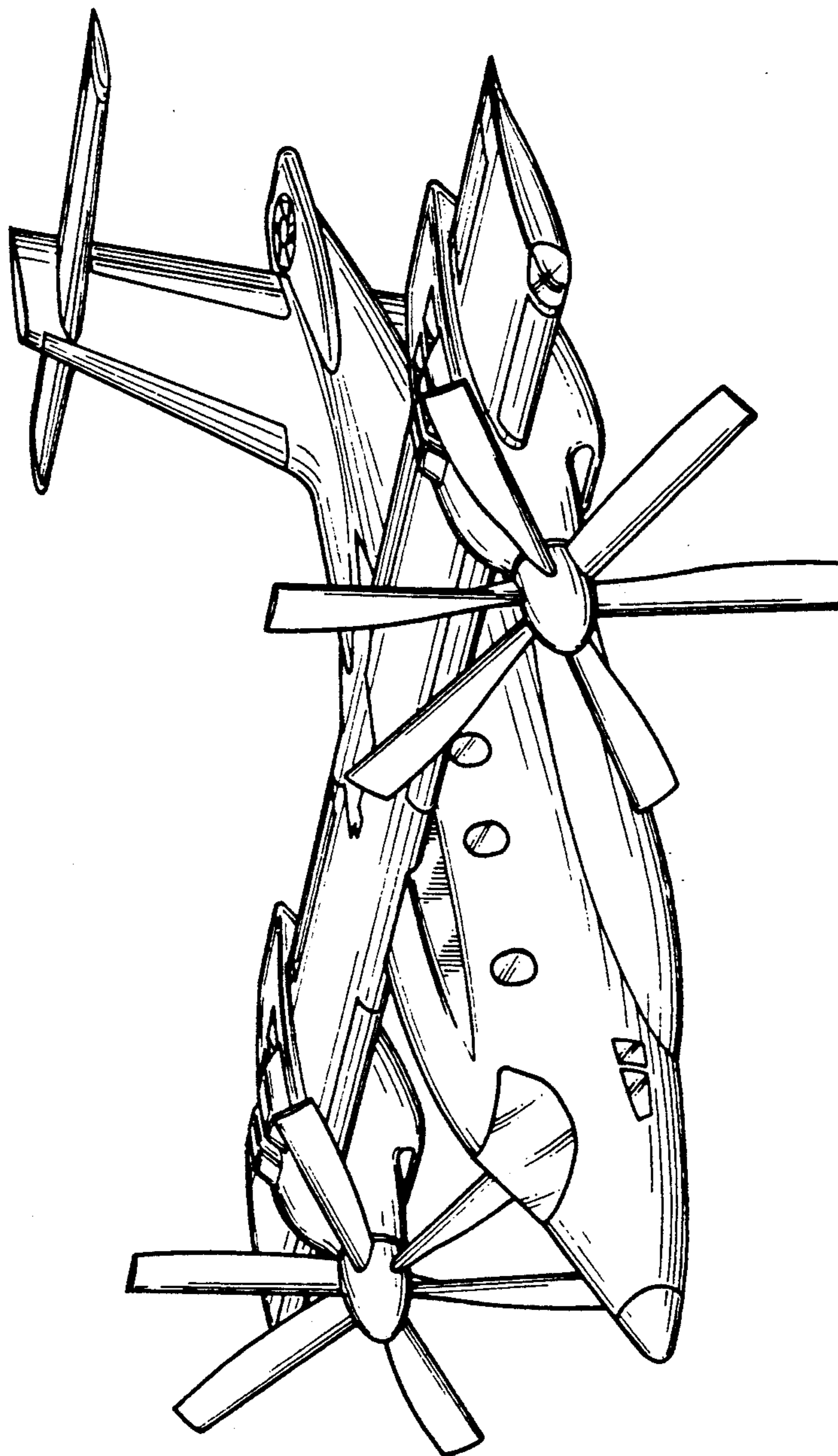

FIG. 1

FIG. 2

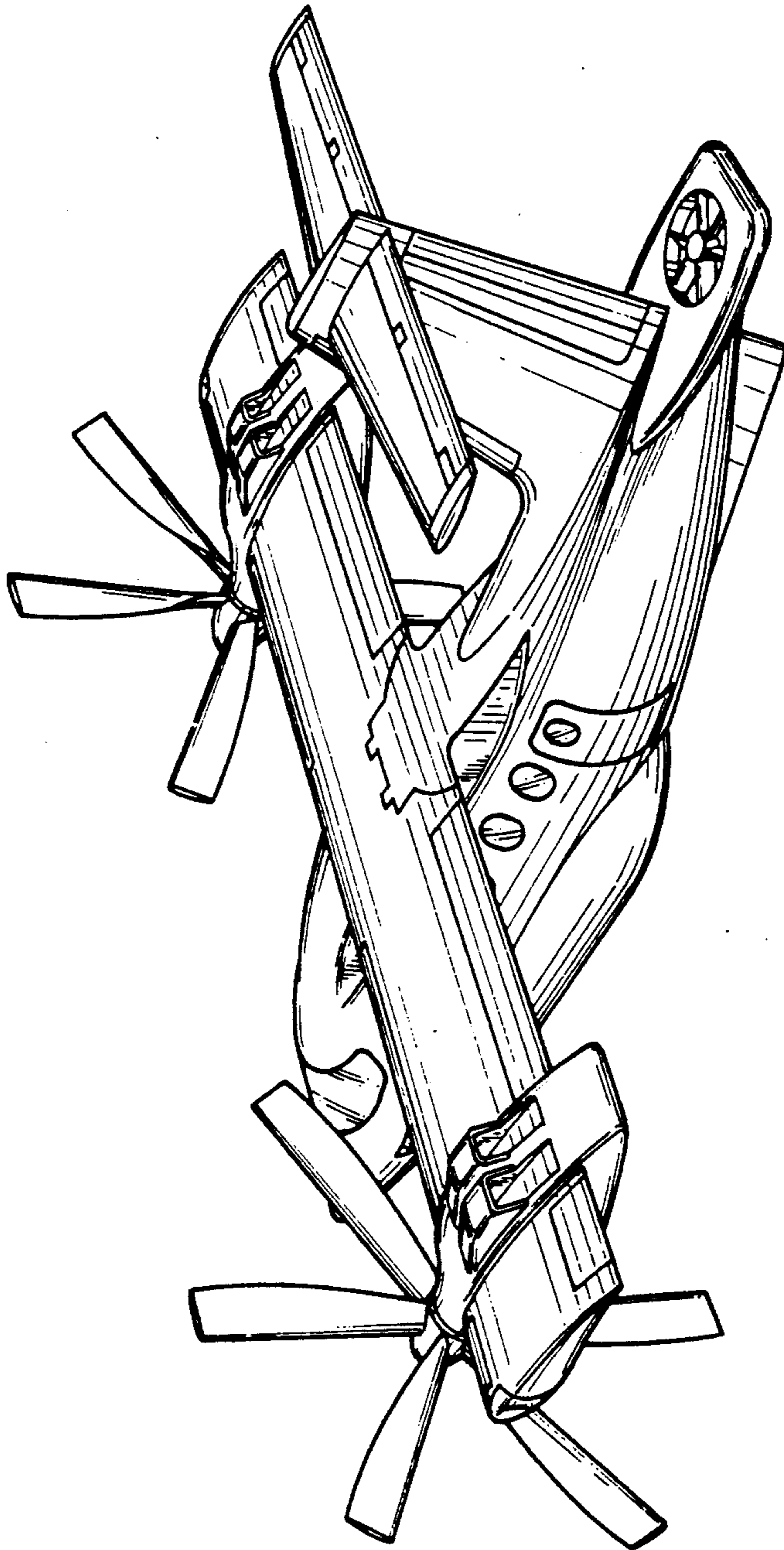

FIG. 3

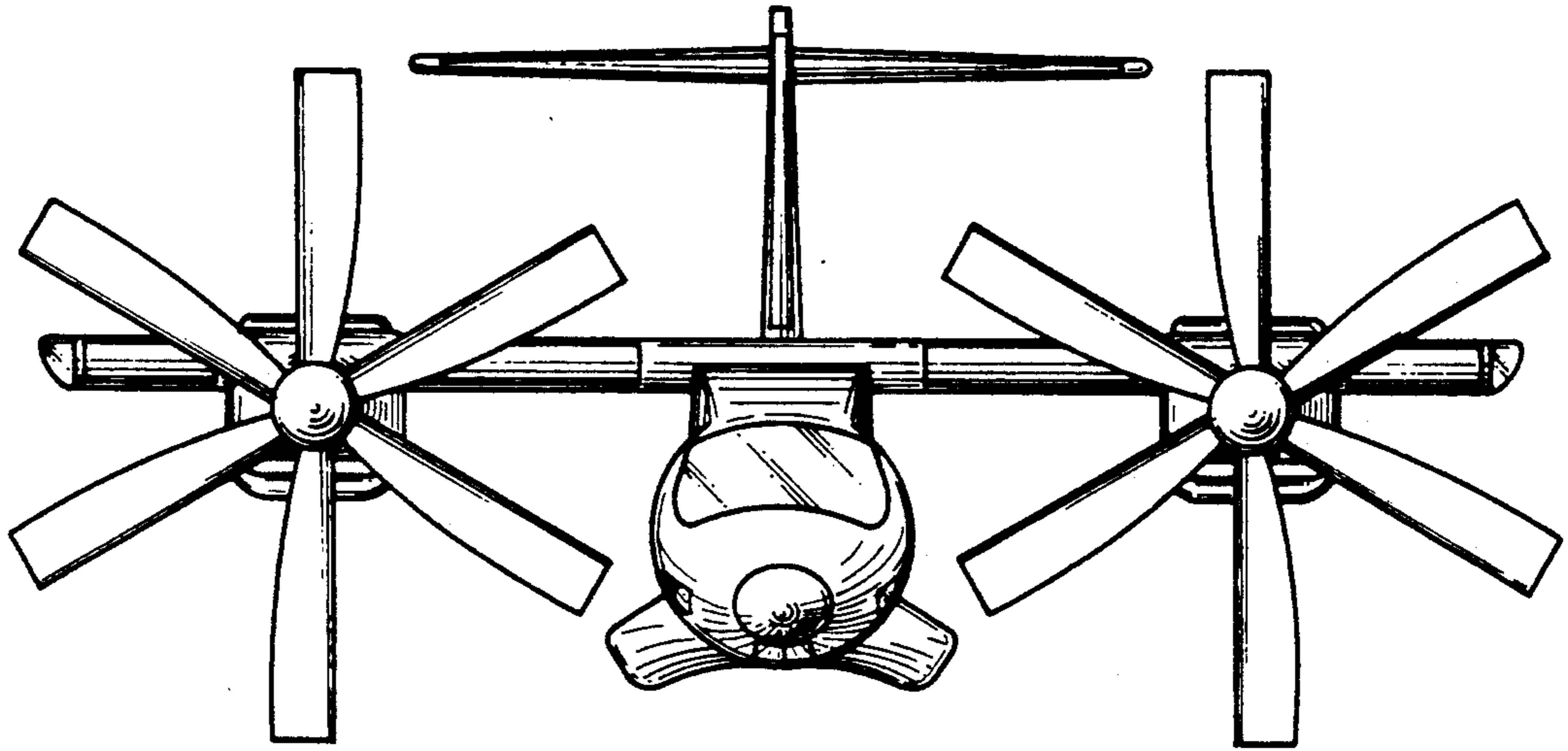

FIG. 4

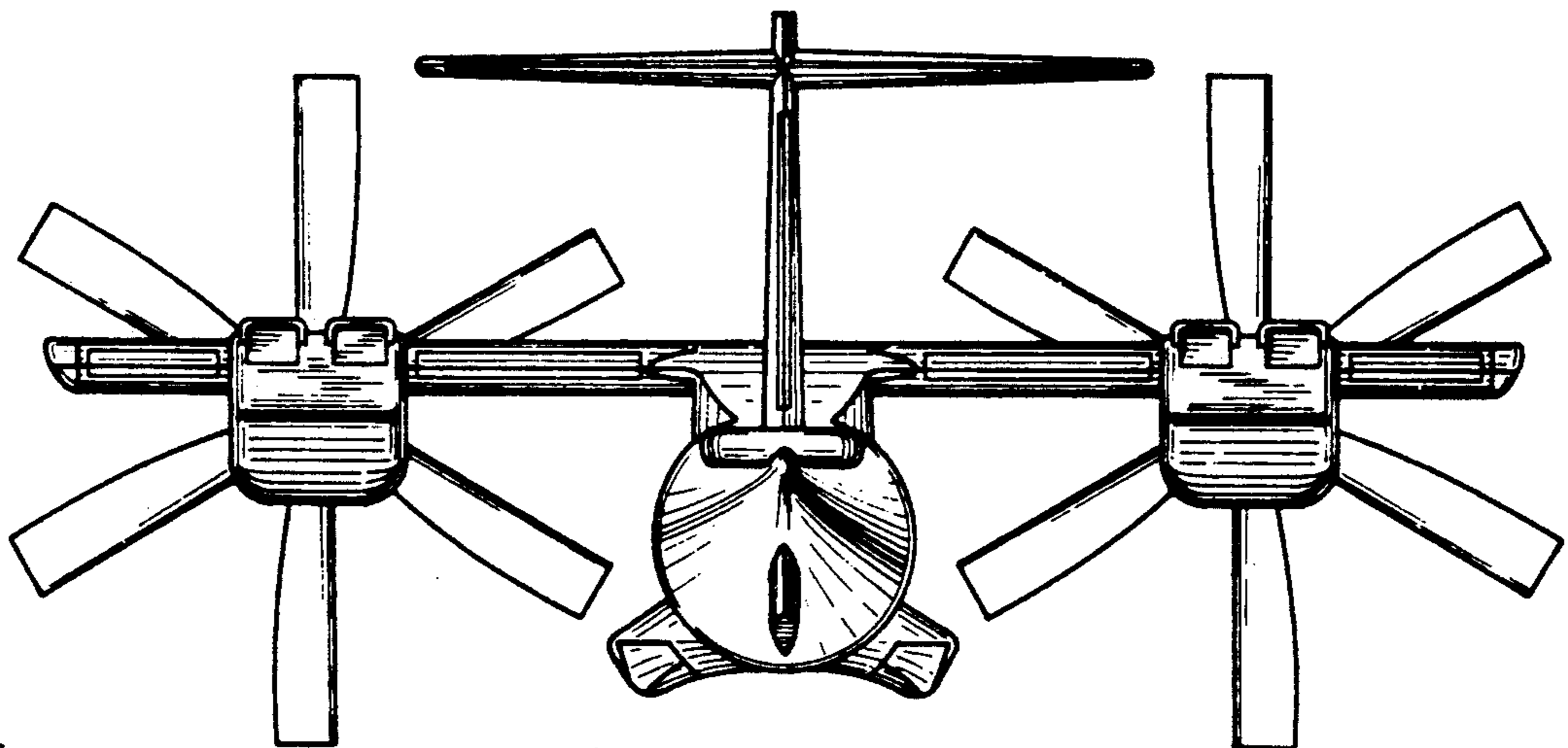

FIG. 5

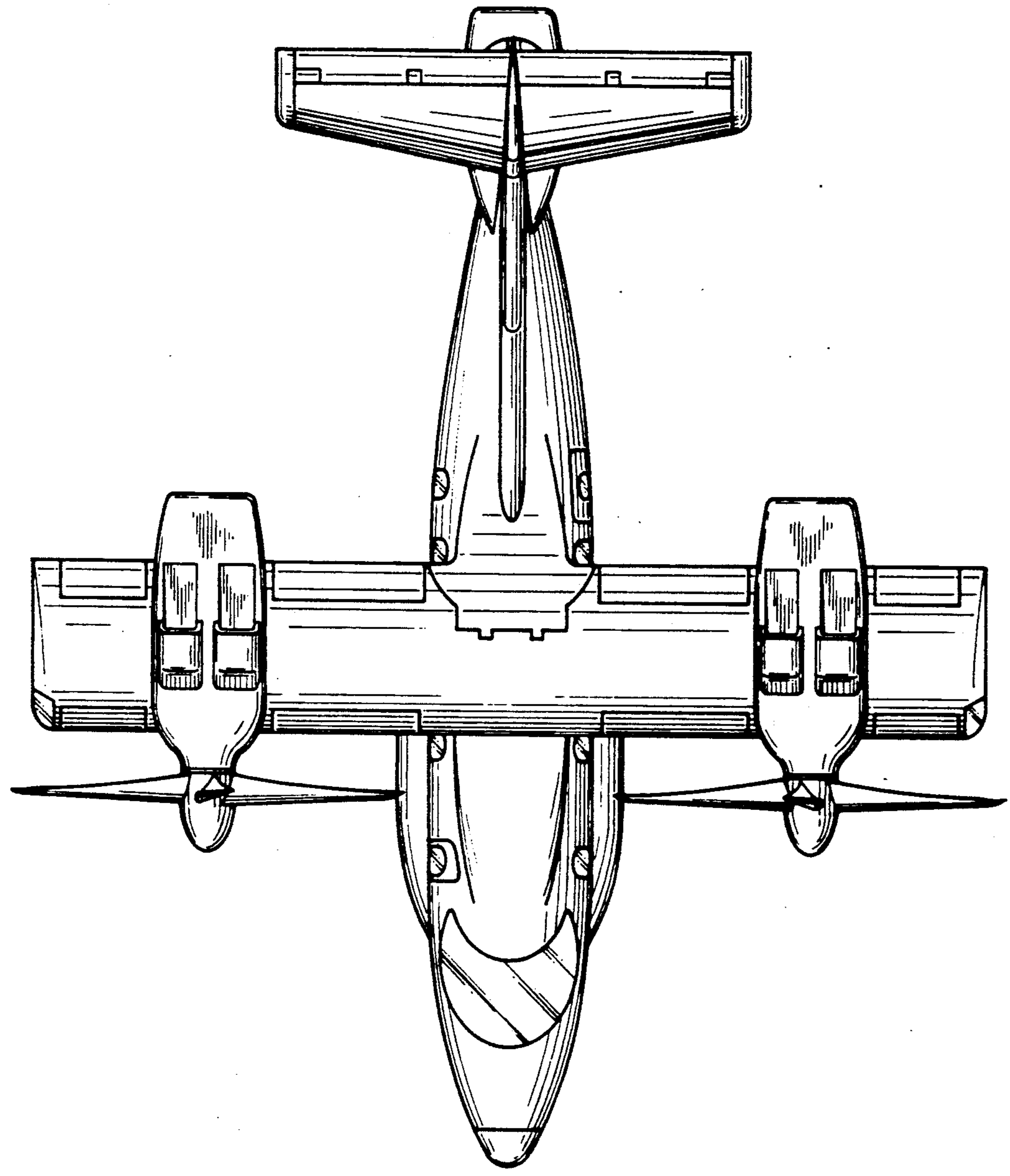

FIG. 6

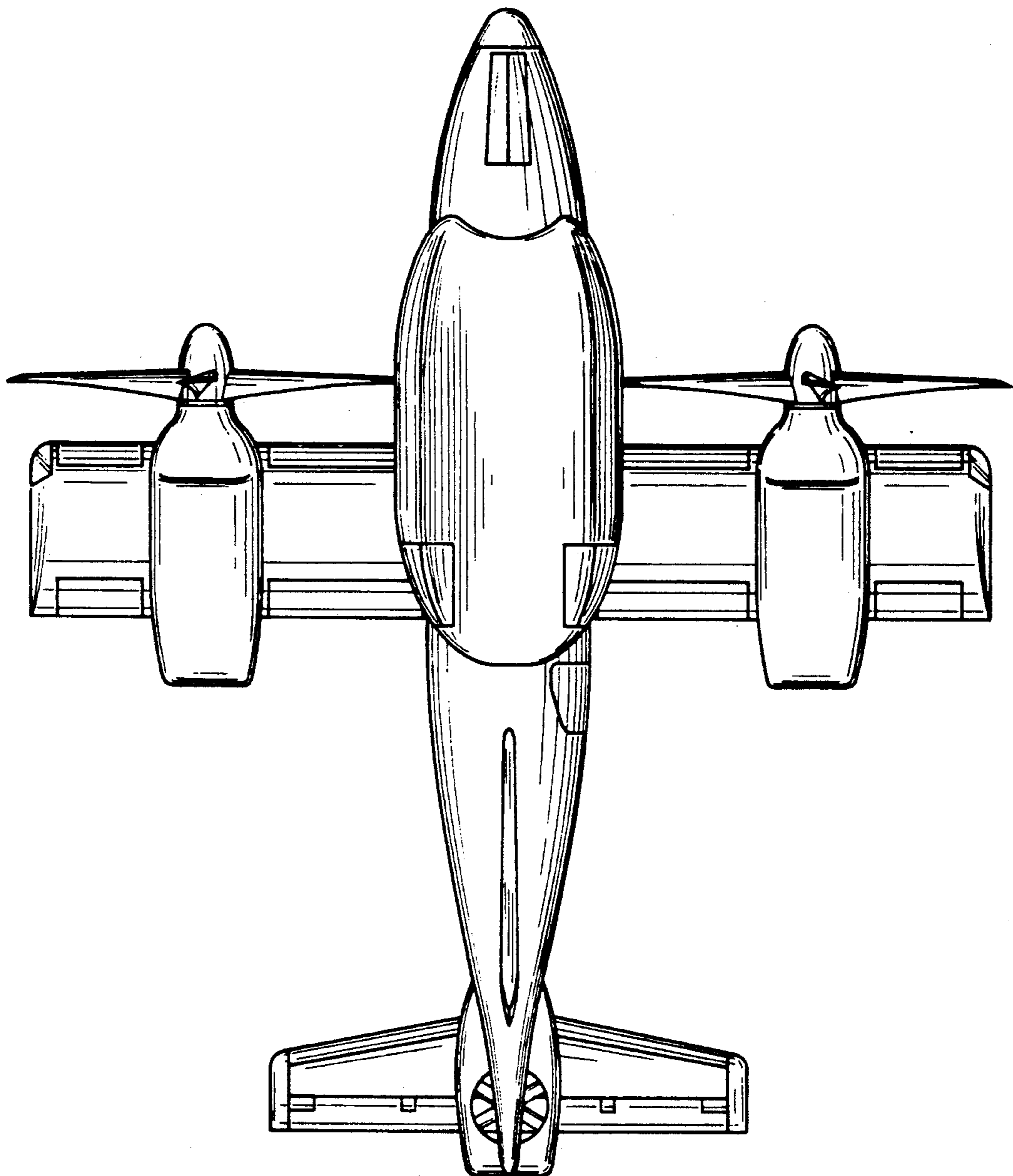

FIG. 7

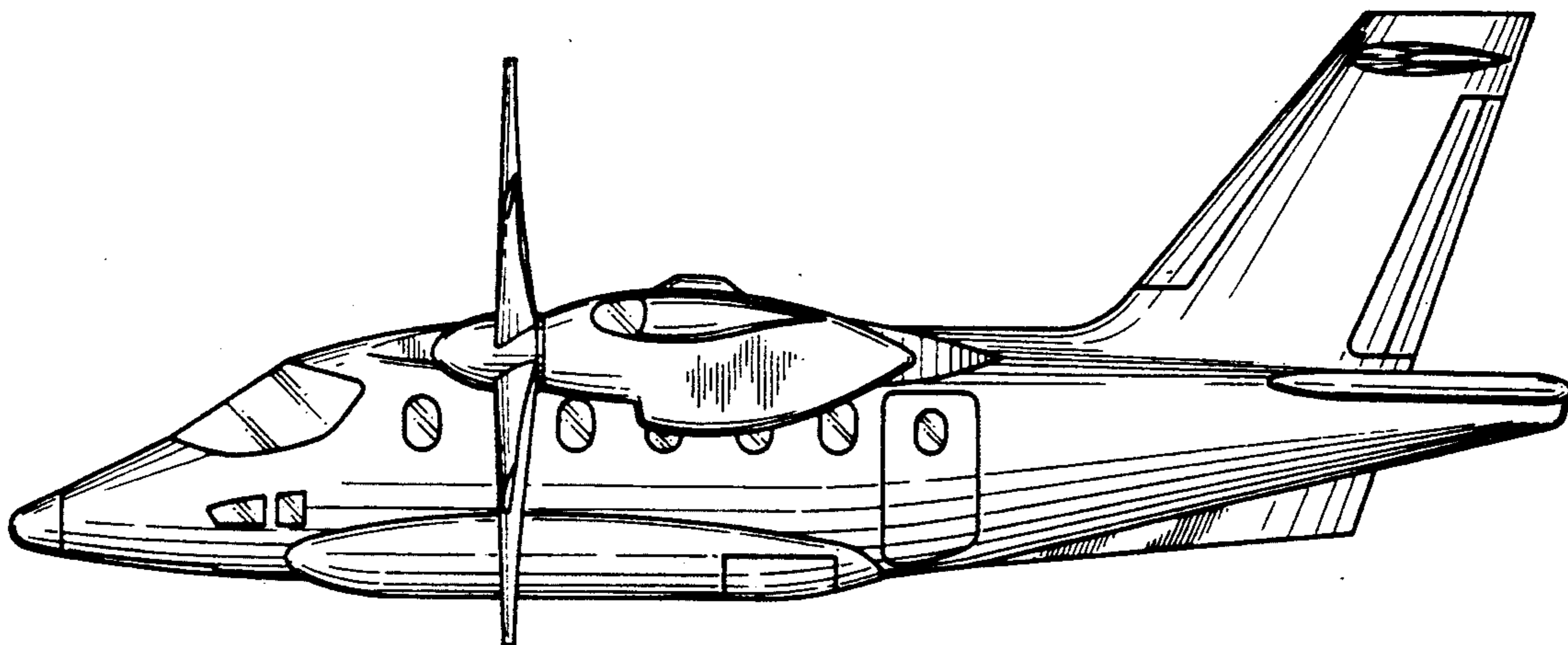

FIG. 8

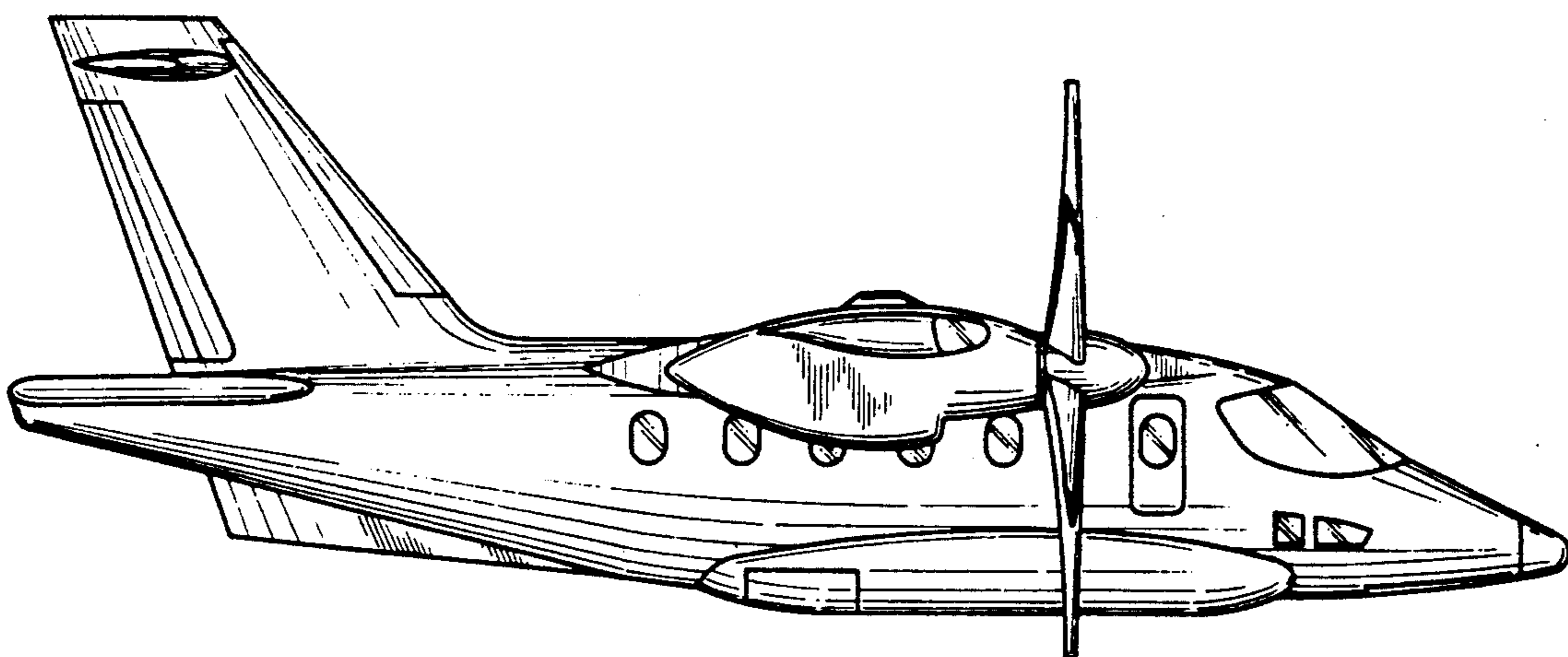

FIG. 9

