



US00D332076S

United States Patent [19]
El-Faham

[11] **Patent Number: Des. 332,076**
[45] **Date of Patent: ** Dec. 29, 1992**

[54] **SET OF MIRRORS FOR VIEWING AN INFANT IN THE REAR SEAT OF A VEHICLE**

4,702,572 10/1987 Cossey 350/639
4,902,118 2/1990 Harris 350/631
4,917,485 4/1990 Baldwin, Sr. 350/627
4,998,813 3/1991 Reynolds et al. 350/624

[76] **Inventor: Ibrahim M. El-Faham, 4014 West, Hollow Creek, Ill. 61615**

Primary Examiner—James M. Gandy
Attorney, Agent, or Firm—Leon Gilden

[**] **Term: 14 Years**

[57] **CLAIM**

[21] **Appl. No.: 482,737**

The ornamental design for a set of mirrors for viewing an infant in the rear seat of a vehicle, as shown.

[22] **Filed: Feb. 21, 1990**

[52] **U.S. Cl. D12/187**

DESCRIPTION

[58] **Field of Search D12/187; D6/300, 310; D28/64.4; 359/838, 843, 844, 850, 857, 860, 864, 866, 868, 871, 872, 874, 876; 248/475.1, 476, 479, 485, 487**

FIG. 1 is a front elevational view of a set of mirrors for viewing an infant in the rear seat of a vehicle showing my new design;

[56] **References Cited**

U.S. PATENT DOCUMENTS

1,986,033 1/1935 Trufant 350/624

FIG. 2 is a rear elevational view thereof;

FIG. 3 is a left side elevational view thereof;

FIG. 4 is a right side elevational view thereof;

FIG. 5 is a top plan view thereof; and,

FIG. 6 is a bottom plan view thereof.

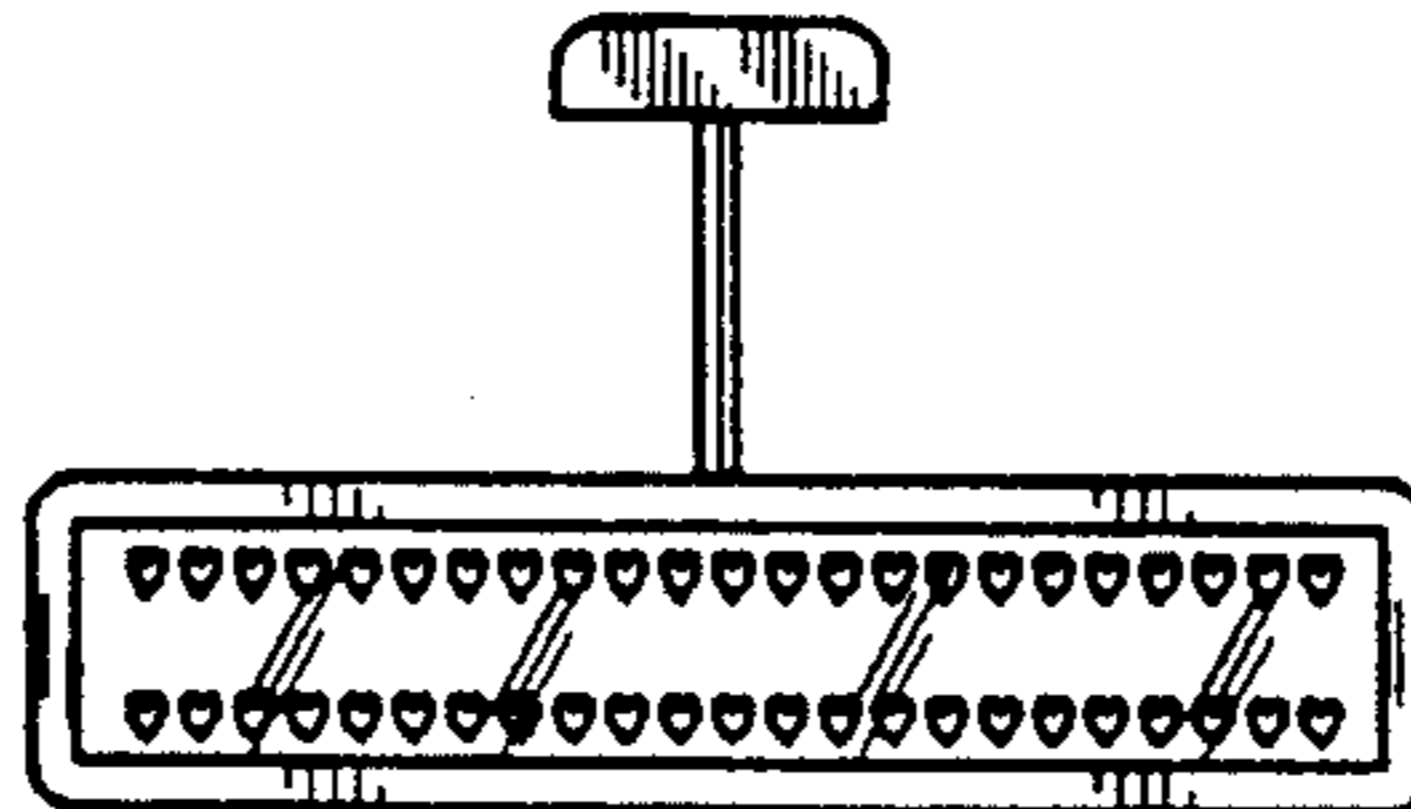
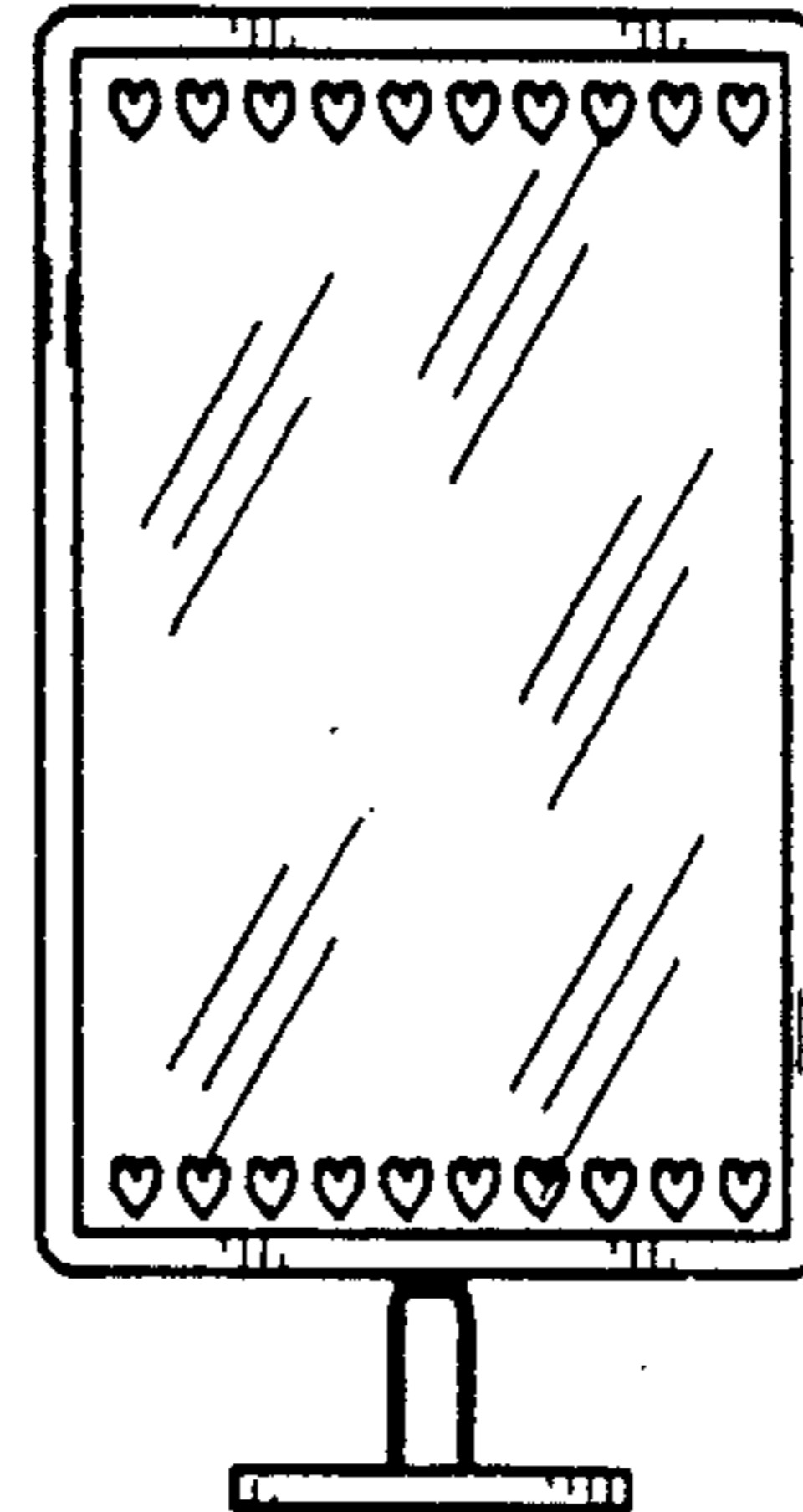
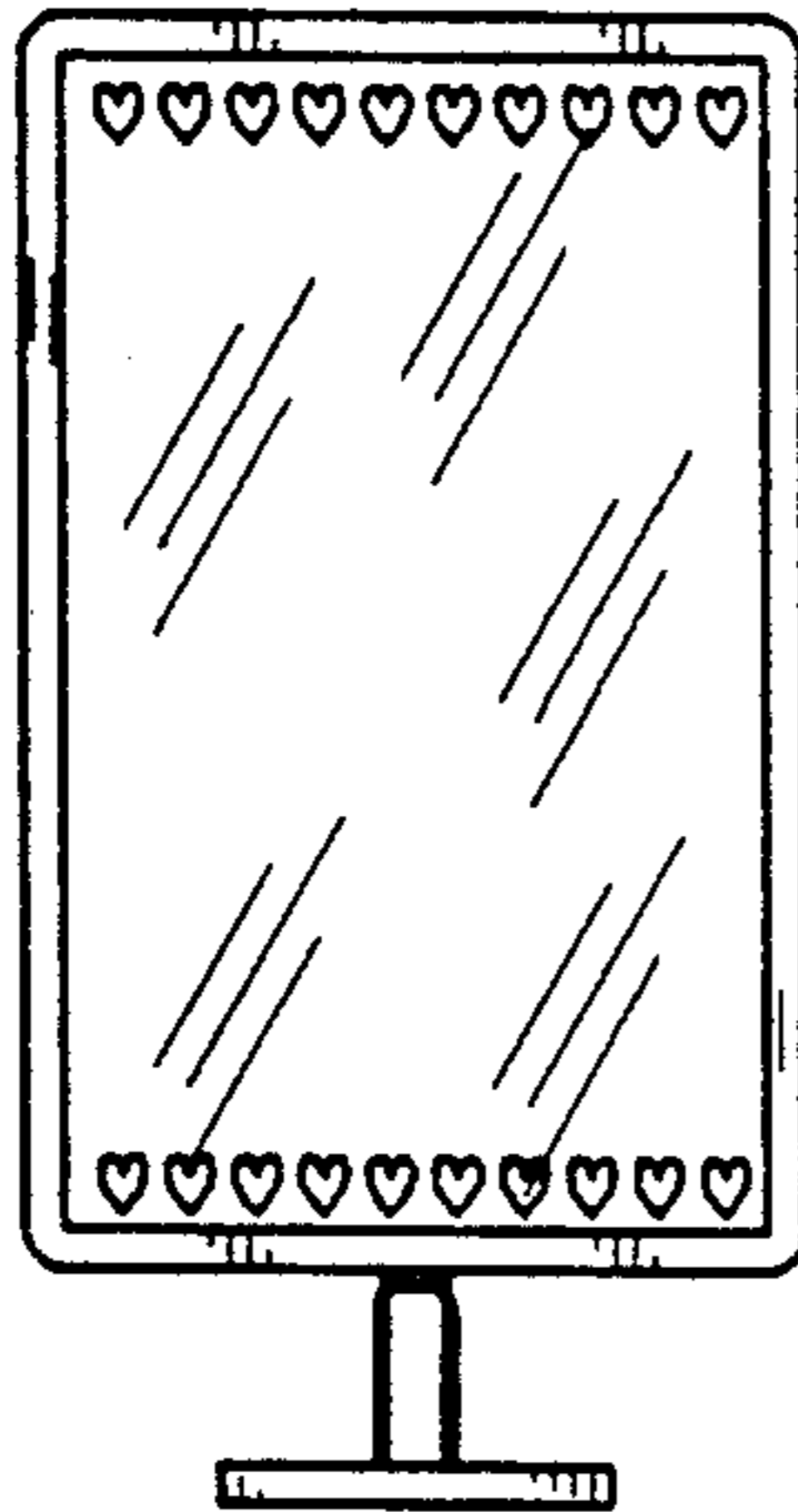

FIG. 1

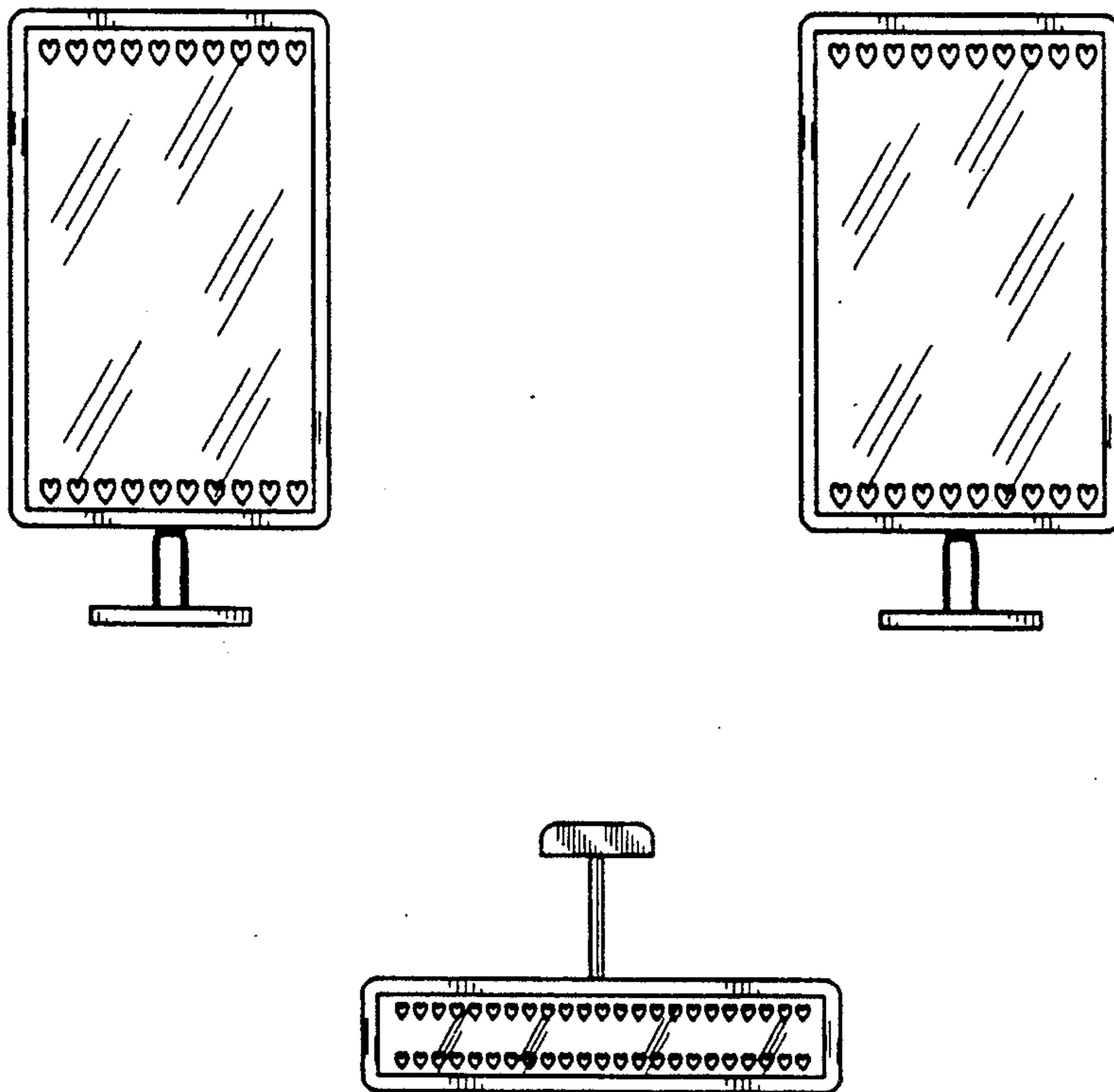

FIG. 2

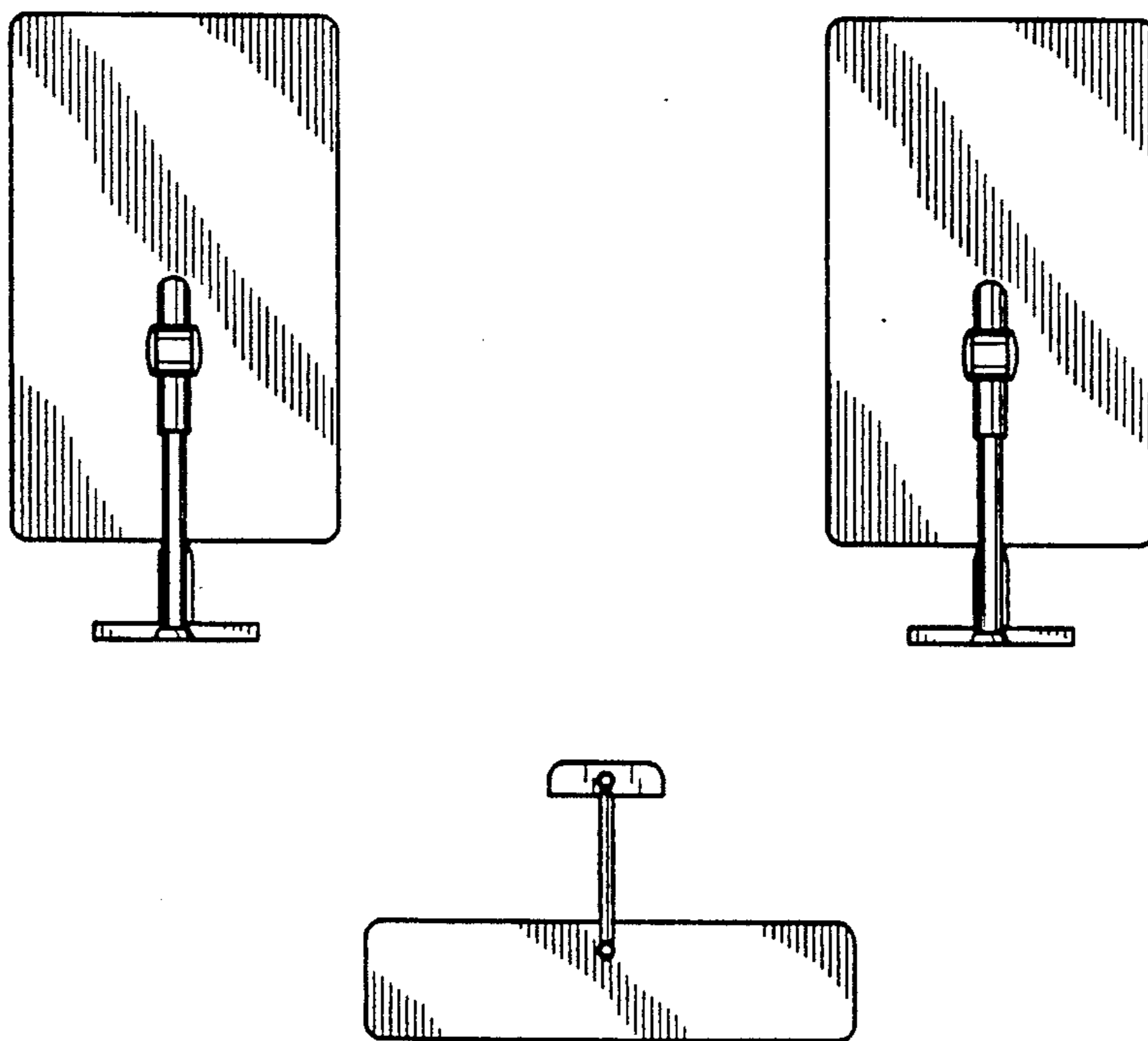

FIG. 3

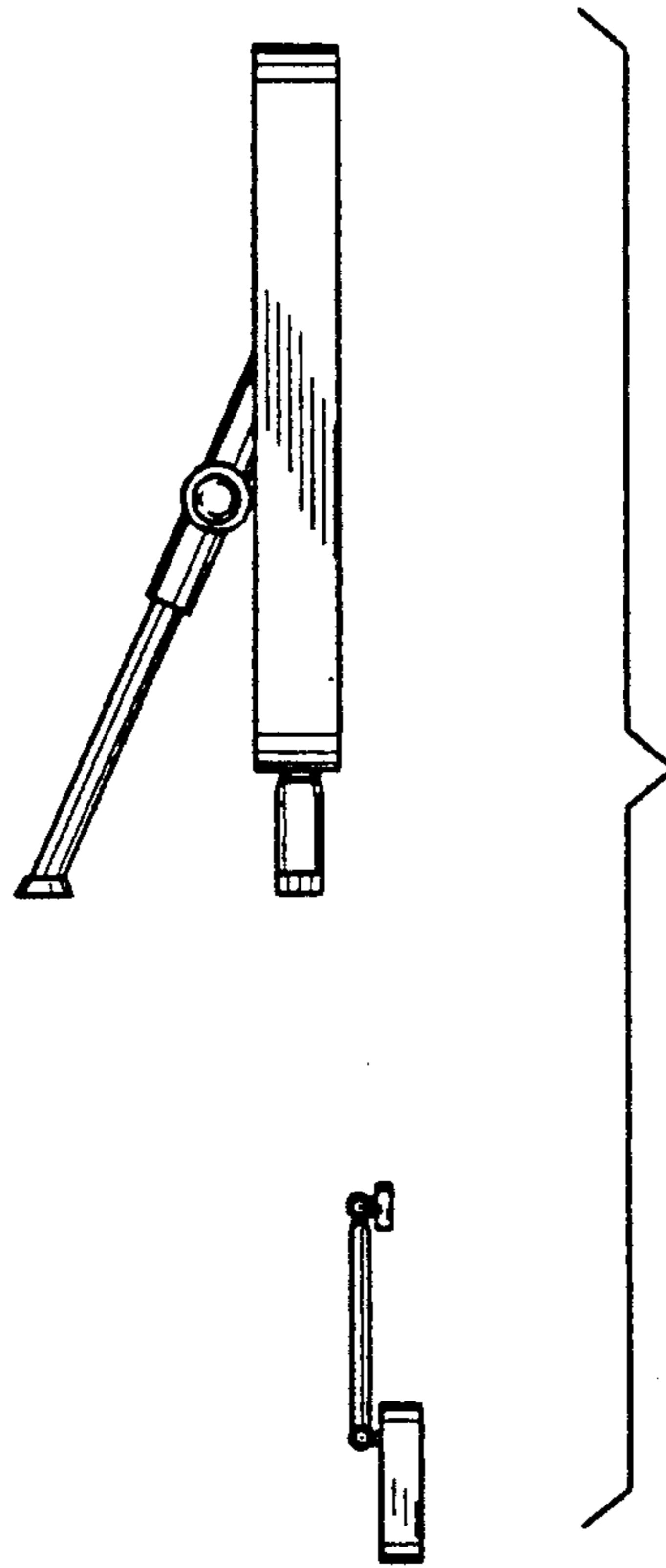

FIG. 4

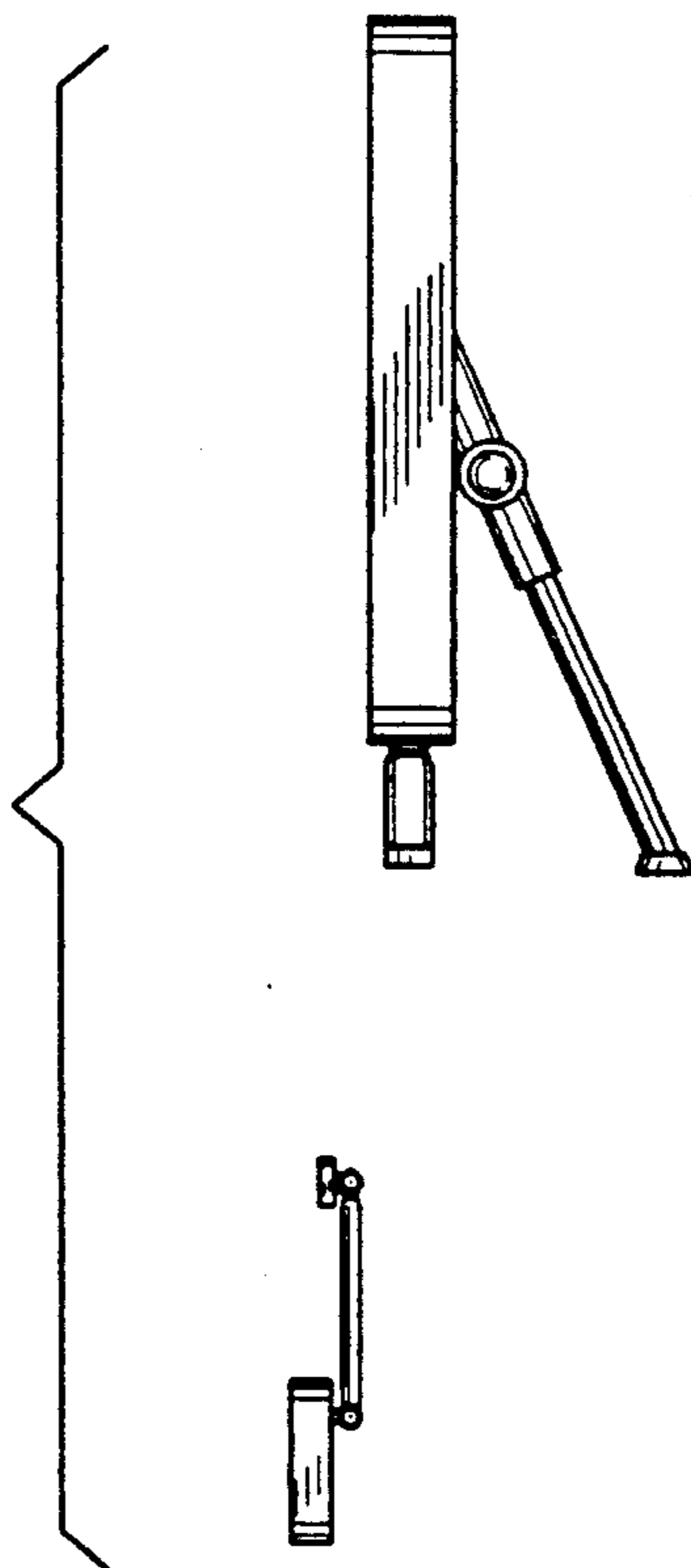

FIG. 5

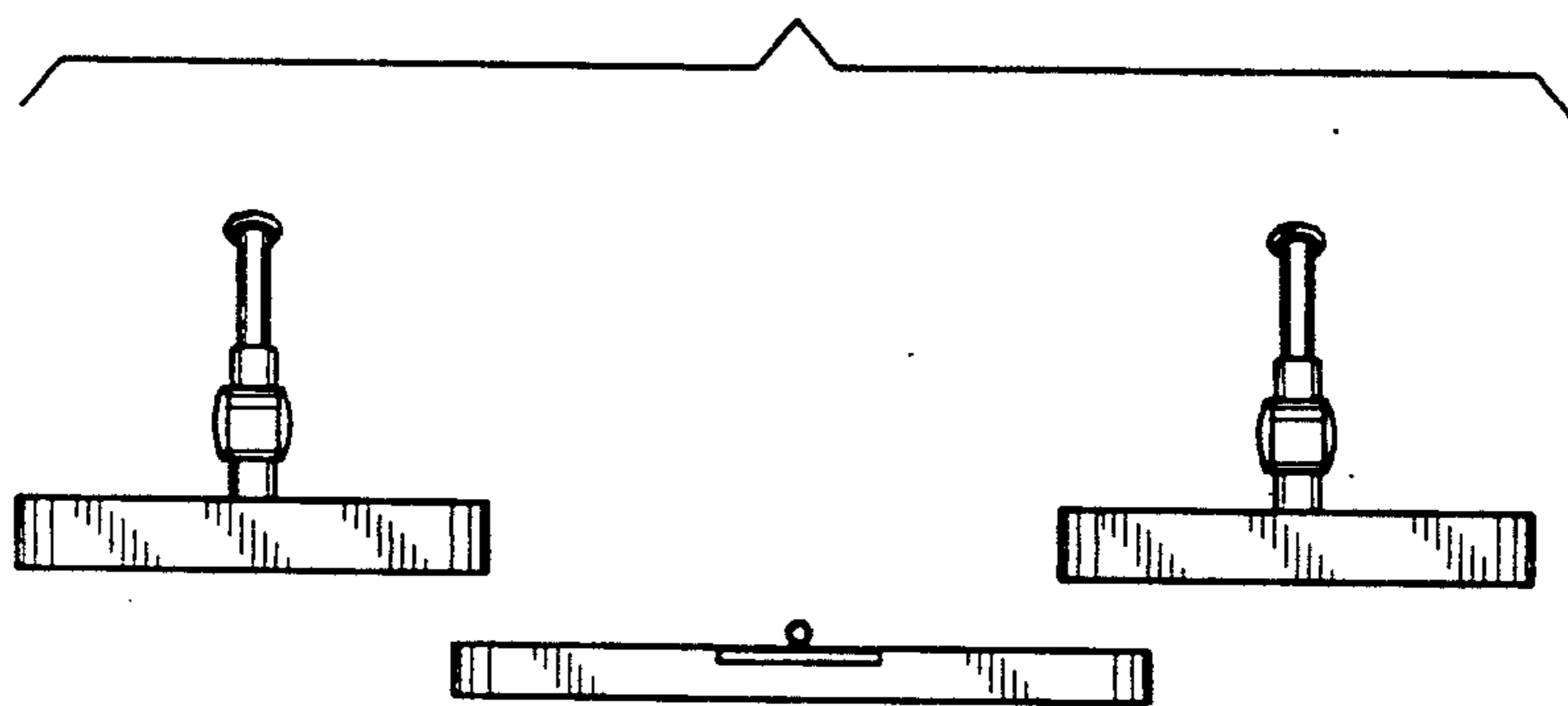

FIG. 6

