



US00D331978S

United States Patent [19]

[11] Patent Number: **Des. 331,978**

Ito

[45] Date of Patent: **** Dec. 22, 1992**

[54] **MARKER LIGHT FOR OVERSIZED CARGO**

[57] **CLAIM**

[76] Inventor: **Randall H. Ito**, 14622 Riata St.,
Midway City, Calif. 92655

The ornamental design for a marker light for oversized cargo, as shown and described.

[**] Term: **14 Years**

DESCRIPTION

[21] Appl. No.: **718,114**

FIG. 1 is a front, right side and bottom perspective view of a marker light for oversized cargo showing my new design;

[22] Filed: **Jun. 20, 1991**

[52] U.S. Cl. **D26/28; D10/114**

FIG. 2 is a front elevational view thereof on a reduced scale;

[58] Field of Search **D26/28-35;
D10/114; 362/61, 80.1, 80, 83, 83.2;
340/468-475, 908, 908.1**

FIG. 3 is a right side elevational view thereof on a reduced scale, the left side elevational view being a mirror image;

[56] **References Cited**

U.S. PATENT DOCUMENTS

2,987,702	6/1961	Yohe	D10/114 X
4,621,253	11/1986	Pillinger et al.	340/472
4,644,449	2/1987	Smith-Williams	362/80
4,903,174	2/1990	Busby	362/61

FIG. 4 is a top plan view thereof on a reduced scale; and,

FIG. 5 is a bottom plan view thereof on a reduced scale. The rear elevational view is plain and unornamented with the exception of the four equal length vertically disposed ribs shown in FIGS. 1, 3, 4 and 5. The power cord for the design is shown in varying positions throughout the drawing figures due to its flexible nature.

Primary Examiner—Susan J. Lucas
Attorney, Agent, or Firm—Richard C. Litman

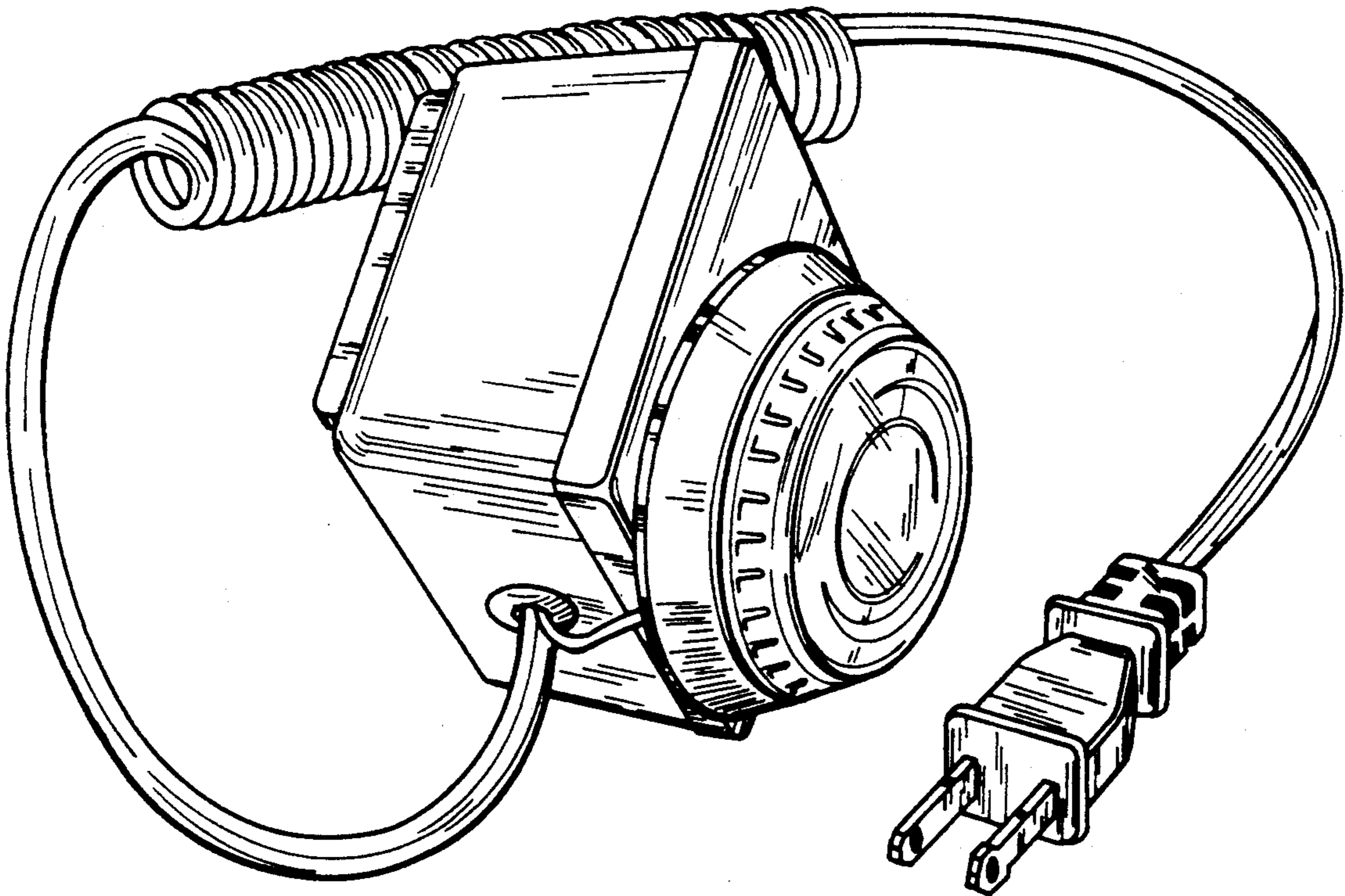

FIG. 1

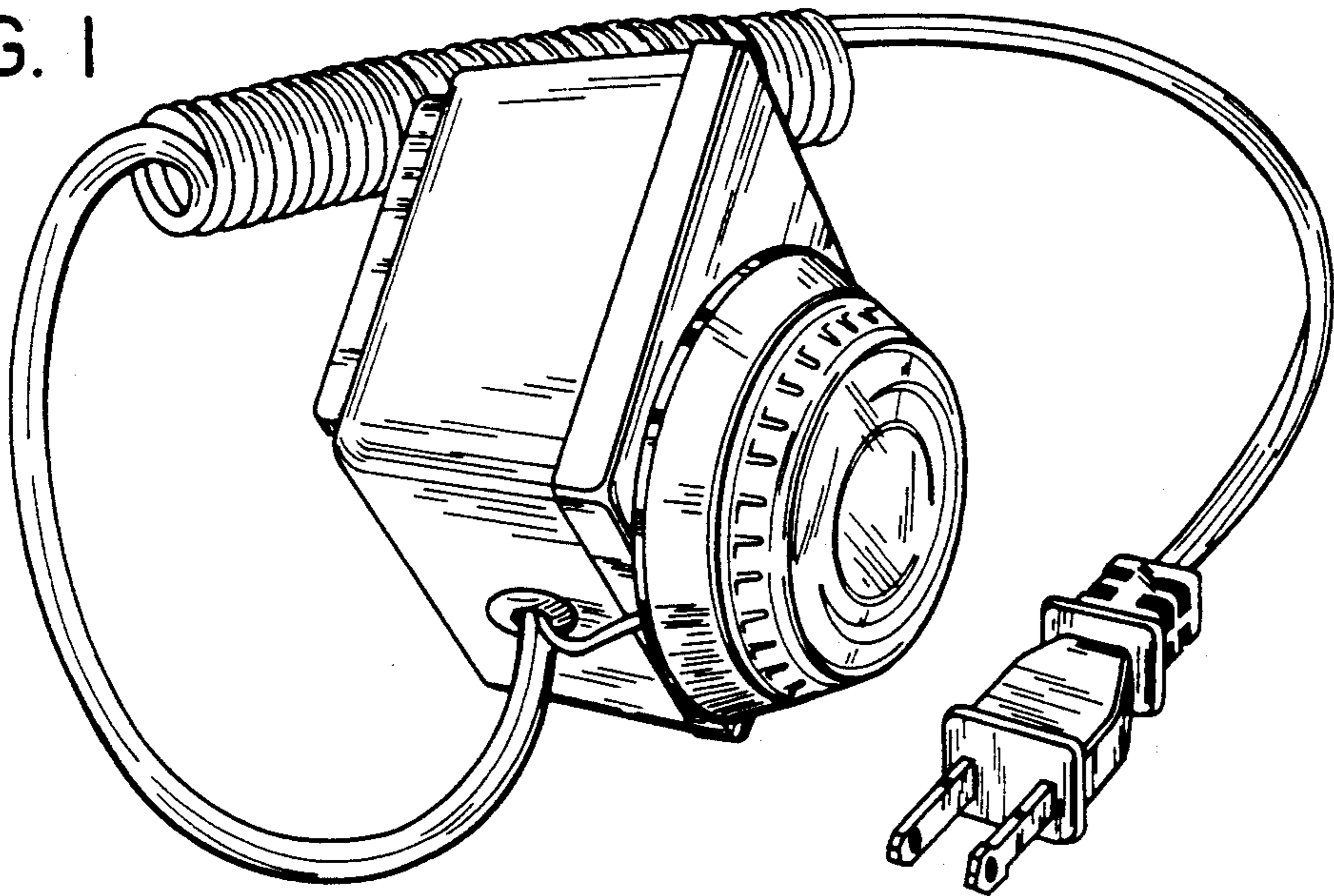

FIG. 2

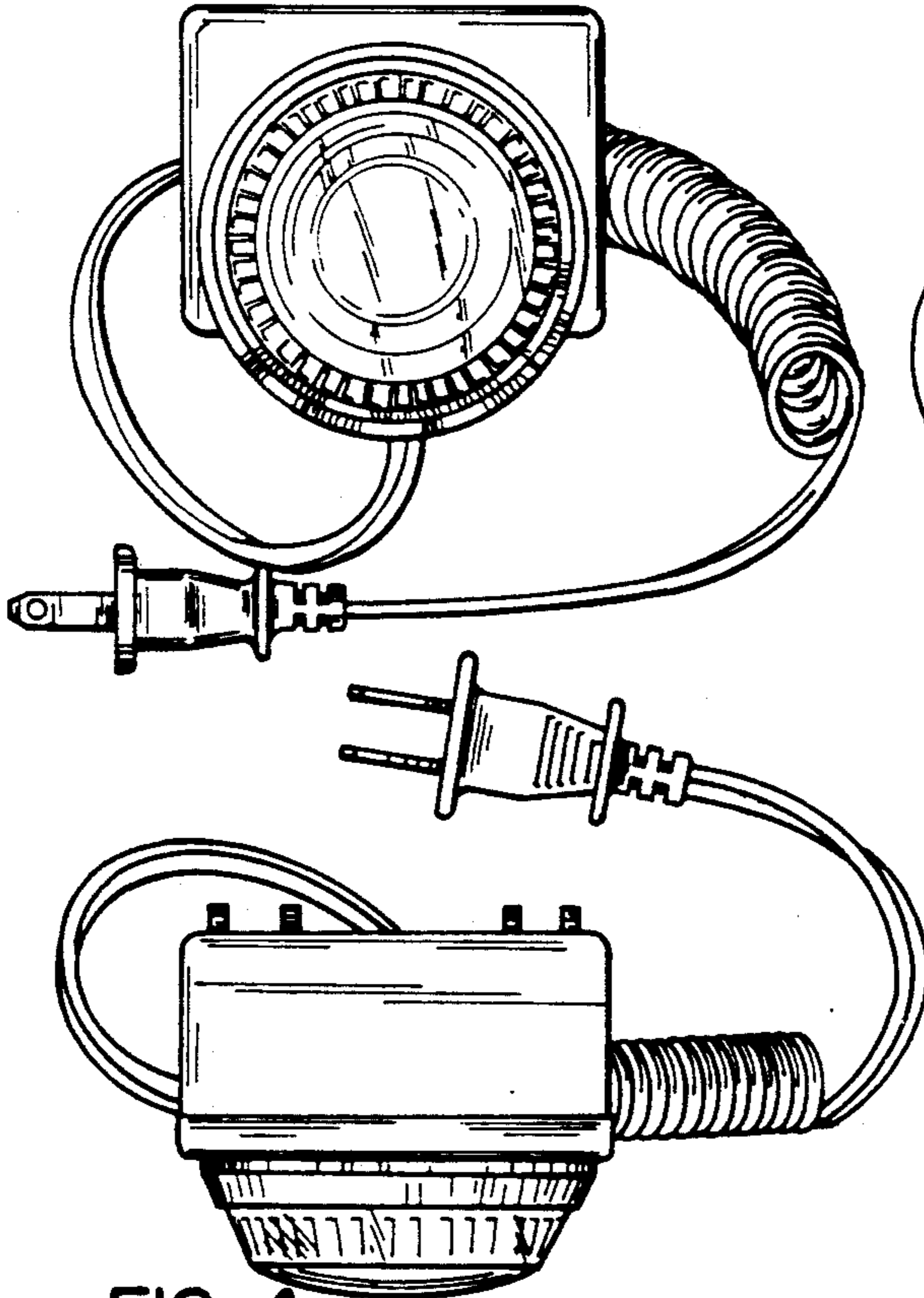

FIG. 3

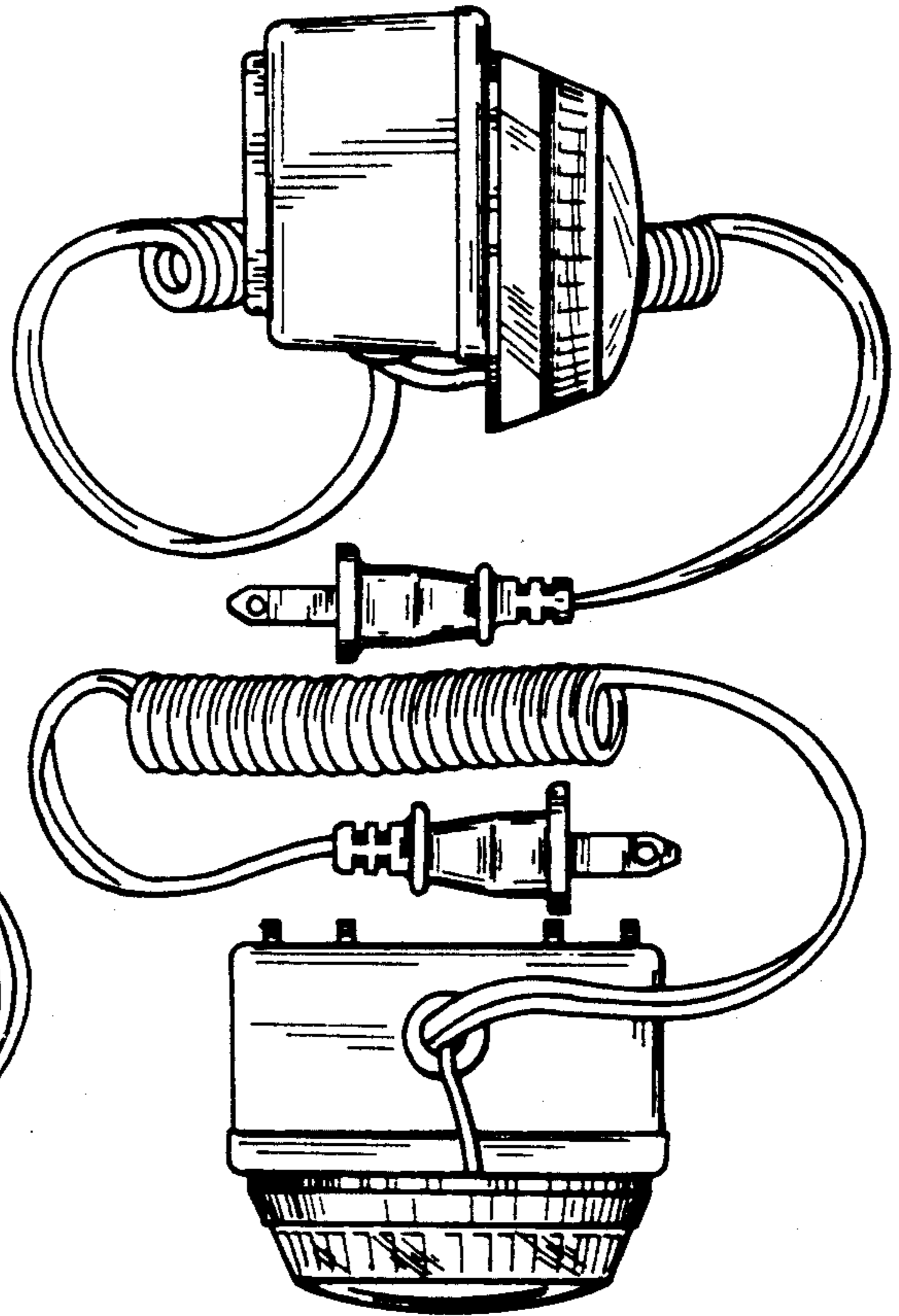

FIG. 4

FIG. 5