



US00D331929S

United States Patent [19]

[11] Patent Number: **Des. 331,929**

Leaf et al.

[45] Date of Patent: **** Dec. 22, 1992**

- [54] **SHROUD FOR AN INTERNAL COMBUSTION ENGINE**
- [75] Inventors: **Curtis D. Leaf**, Minneapolis; **Richard L. Hollar**, Osseo, both of Minn.
- [73] Assignee: **Onan Corporation**, Minneapolis, Minn.
- [**] Term: **14 Years**
- [21] Appl. No.: **379,170**
- [22] Filed: **Jul. 12, 1989**
- [52] U.S. Cl. **D15/1**
- [58] Field of Search **D15/1, 3, 5; 123/56 BA, 123/52 R, 56 A, 56 B, 56 BC, 311, 198 E**

former Gasoline Engine, A-932A, dated Dec. 1988, two (2) pages.
 Onan Corporation specification sheet for P218V Performer Gasoline Engine, A-931A, dated Dec. 1988, two (2) pages.
 Onan Corporation specification sheet for P216V Performer Gasoline Engine, A-930B, dated Jun. 1989, two(2) pages.

Primary Examiner—A. Hugo Word
Assistant Examiner—R. Seifert
Attorney, Agent, or Firm—Merchant, Gould, Smith, Edell, Welter & Schmidt

[56] References Cited

U.S. PATENT DOCUMENTS

D. 187,808	5/1960	Gale	D15/1
D. 238,197	12/1975	Fernandez	D15/5
D. 305,432	1/1990	Hashigaki	D15/1
D. 307,147	4/1990	Sasaki	D15/1
D. 309,612	7/1990	Nakagawa	D15/1
4,233,043	11/1980	Catterson	D15/3
4,867,120	9/1989	Boda et al.	123/198 E

OTHER PUBLICATIONS

Onan Corporation specification sheet for B48G Gasoline Engine, A-829E, dated Jul. 1985, two (2) pages.
 Onan Corporation specification sheet for P220V Per-

[57] CLAIM

The ornamental design for a shroud for an internal combustion engine, as shown and described.

DESCRIPTION

FIG. 1 is a front and top right perspective view of an internal combustion engine showing our new design; FIG. 2 is a front elevational view thereof; FIG. 3 is a rear elevational view thereof; FIG. 4 is a right side elevational view thereof; FIG. 5 is a left side elevational view thereof; FIG. 6 is a top plan view thereof; and, FIG. 7 is a bottom plan view thereof.

The broken line showing of various engine components is for illustrative purposes only and forms no part of the claimed design.

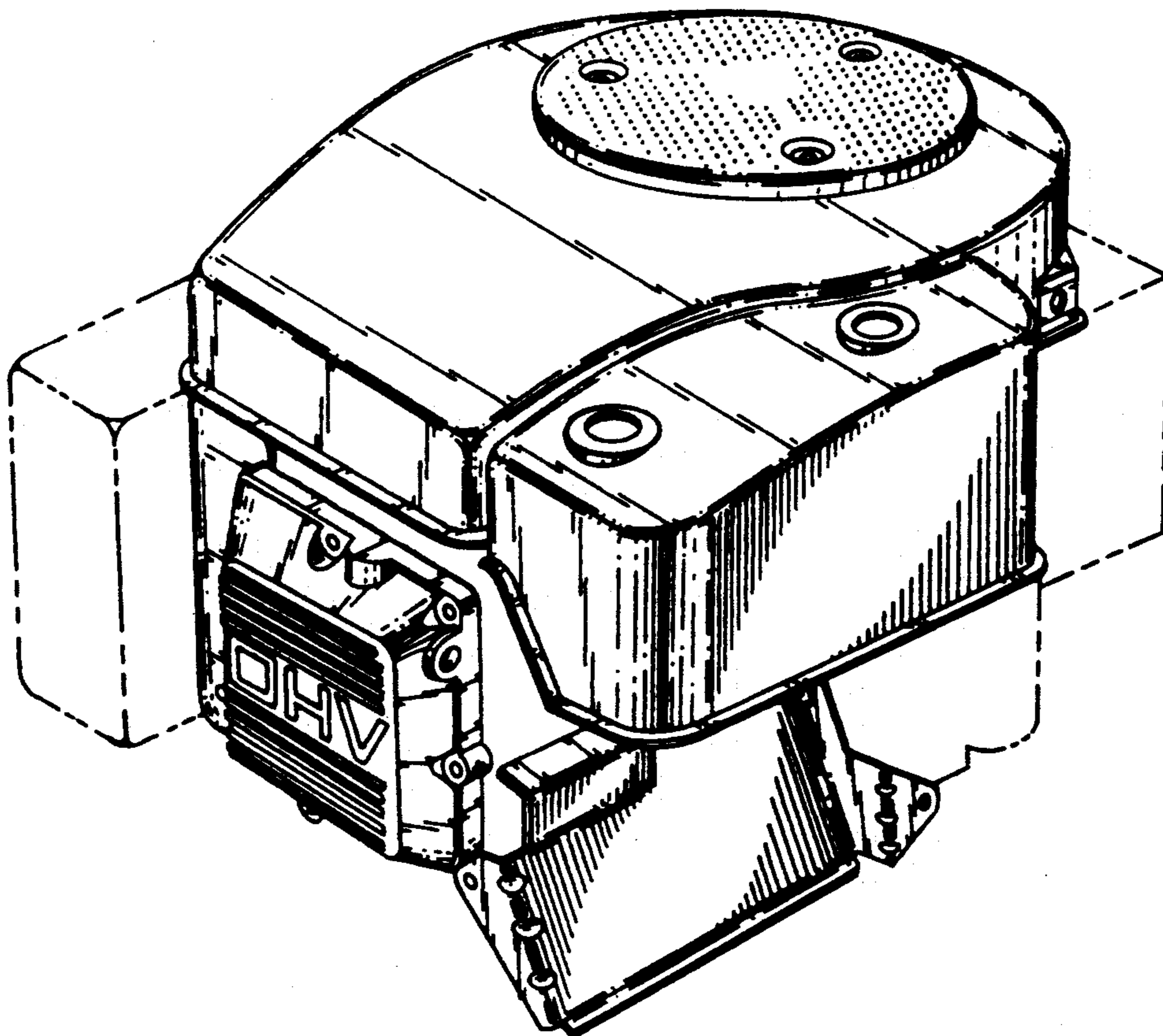

FIG. 1

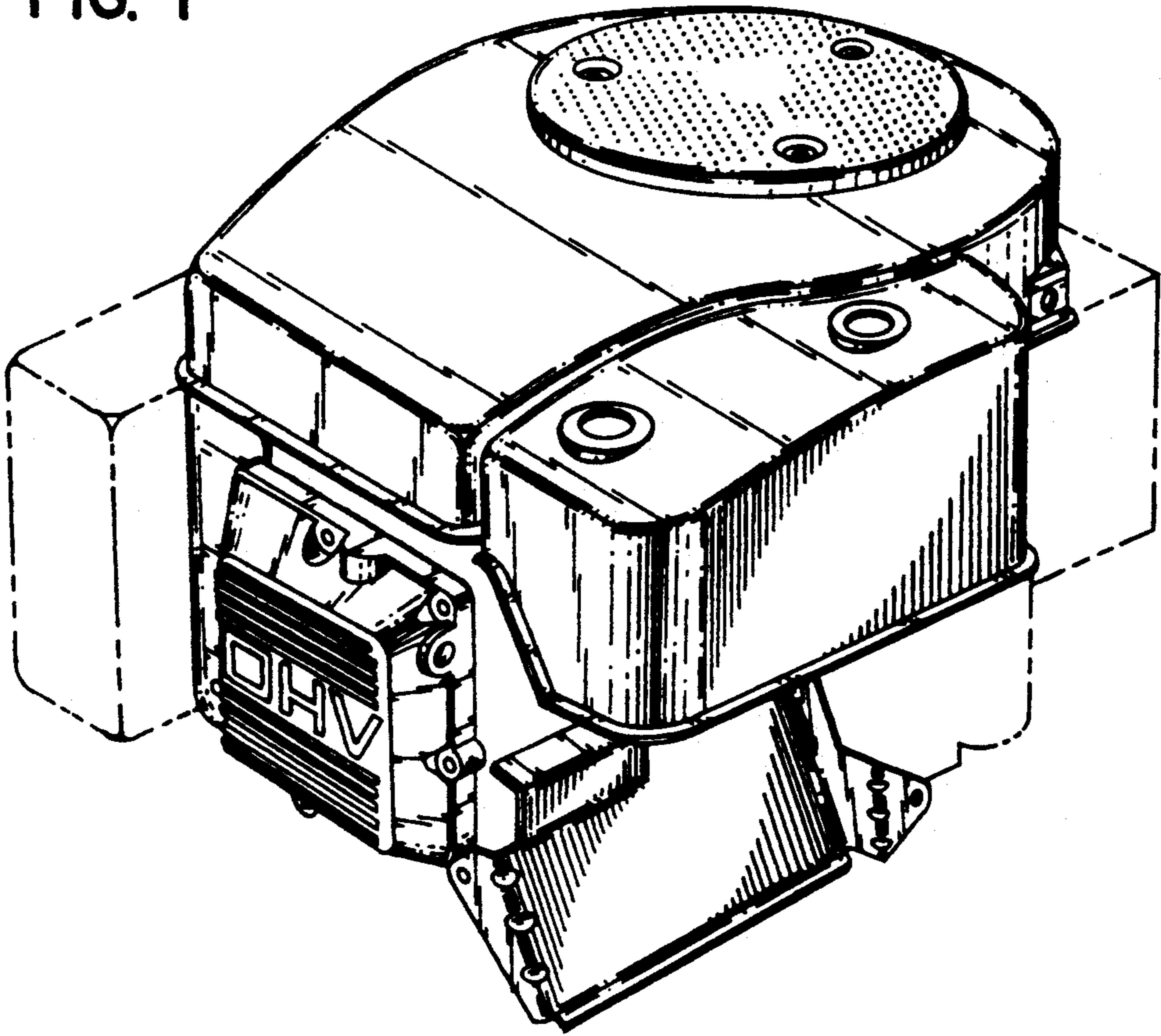

FIG. 2

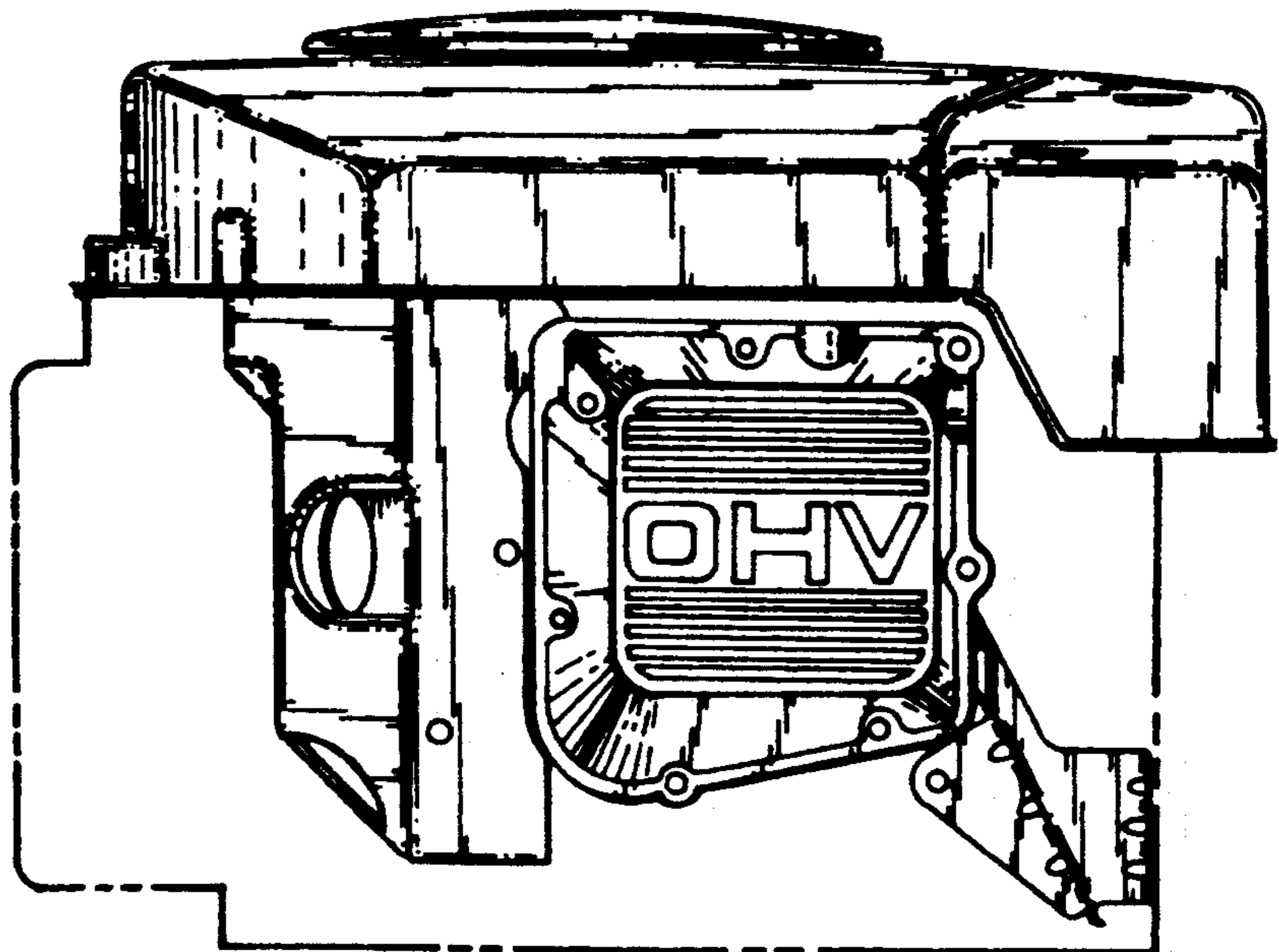

FIG. 4

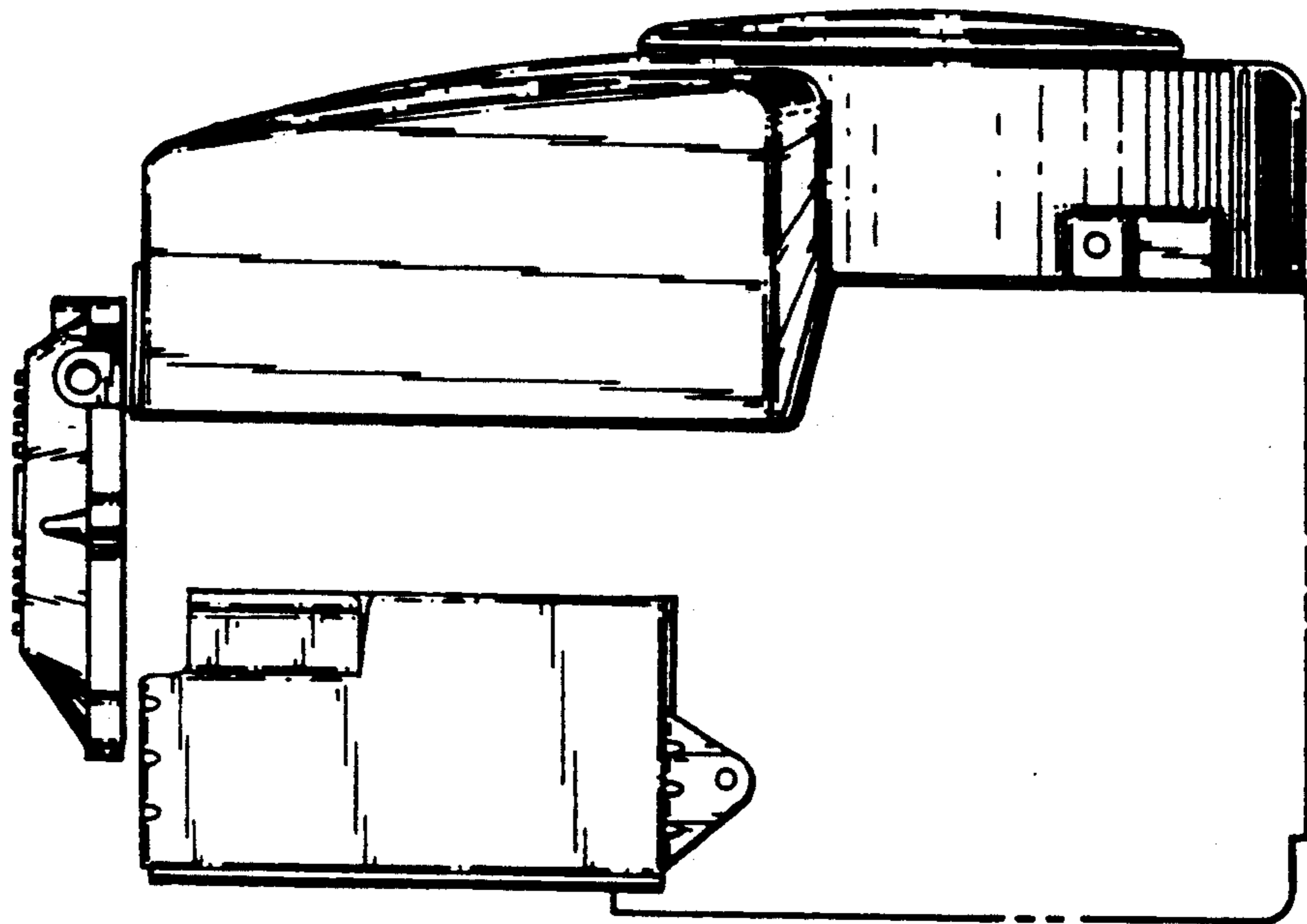

FIG. 3

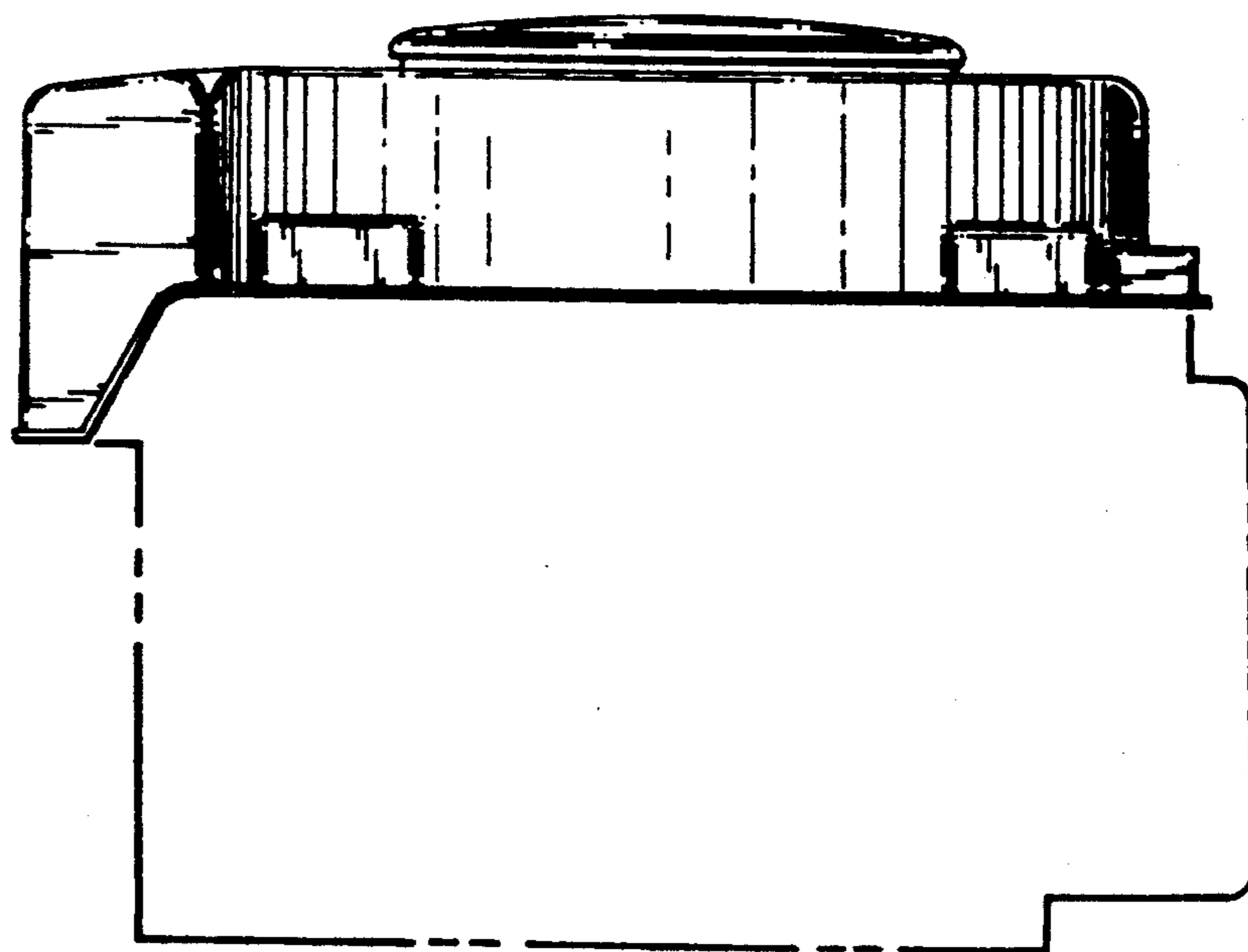

FIG. 6

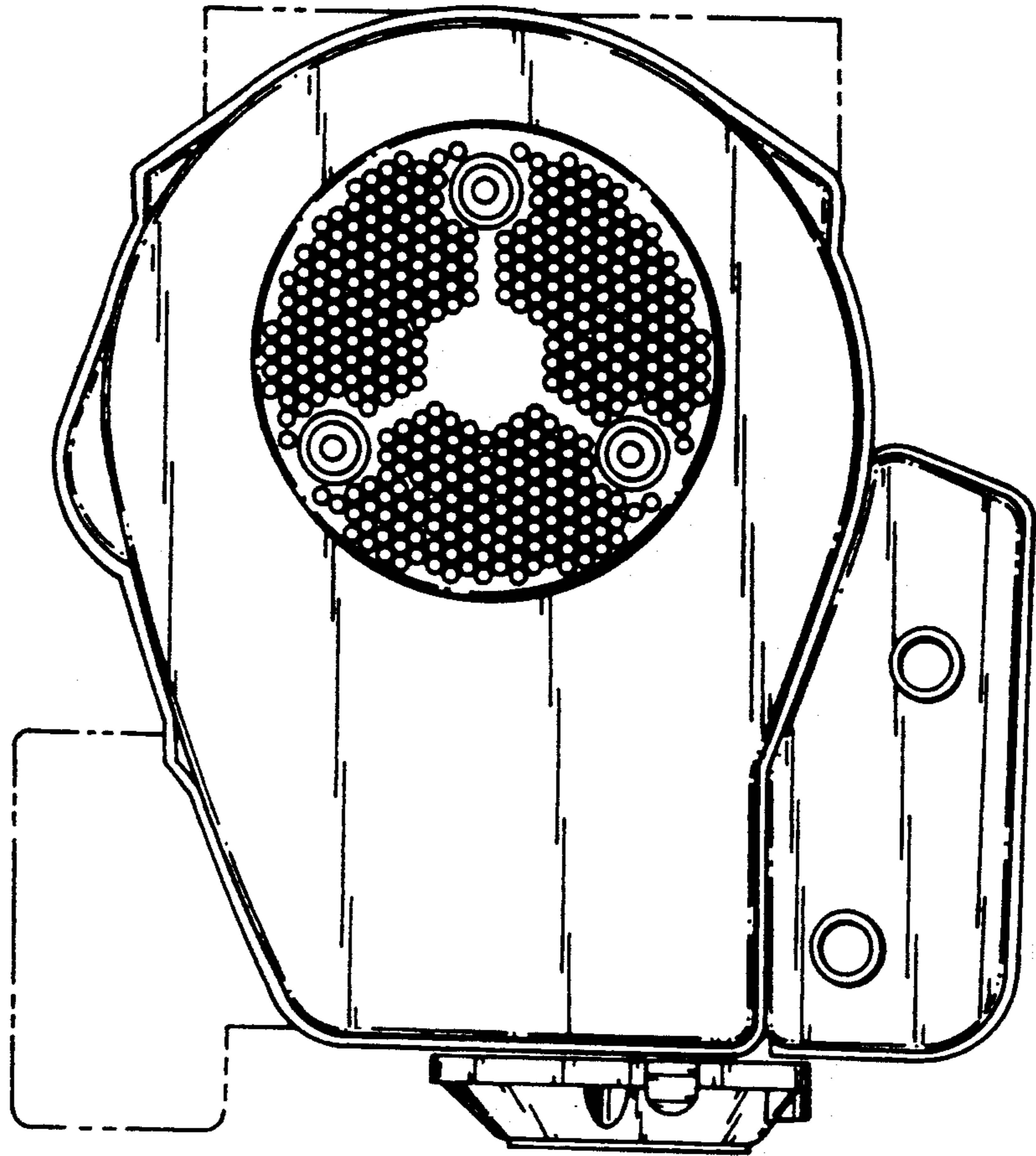

FIG. 5

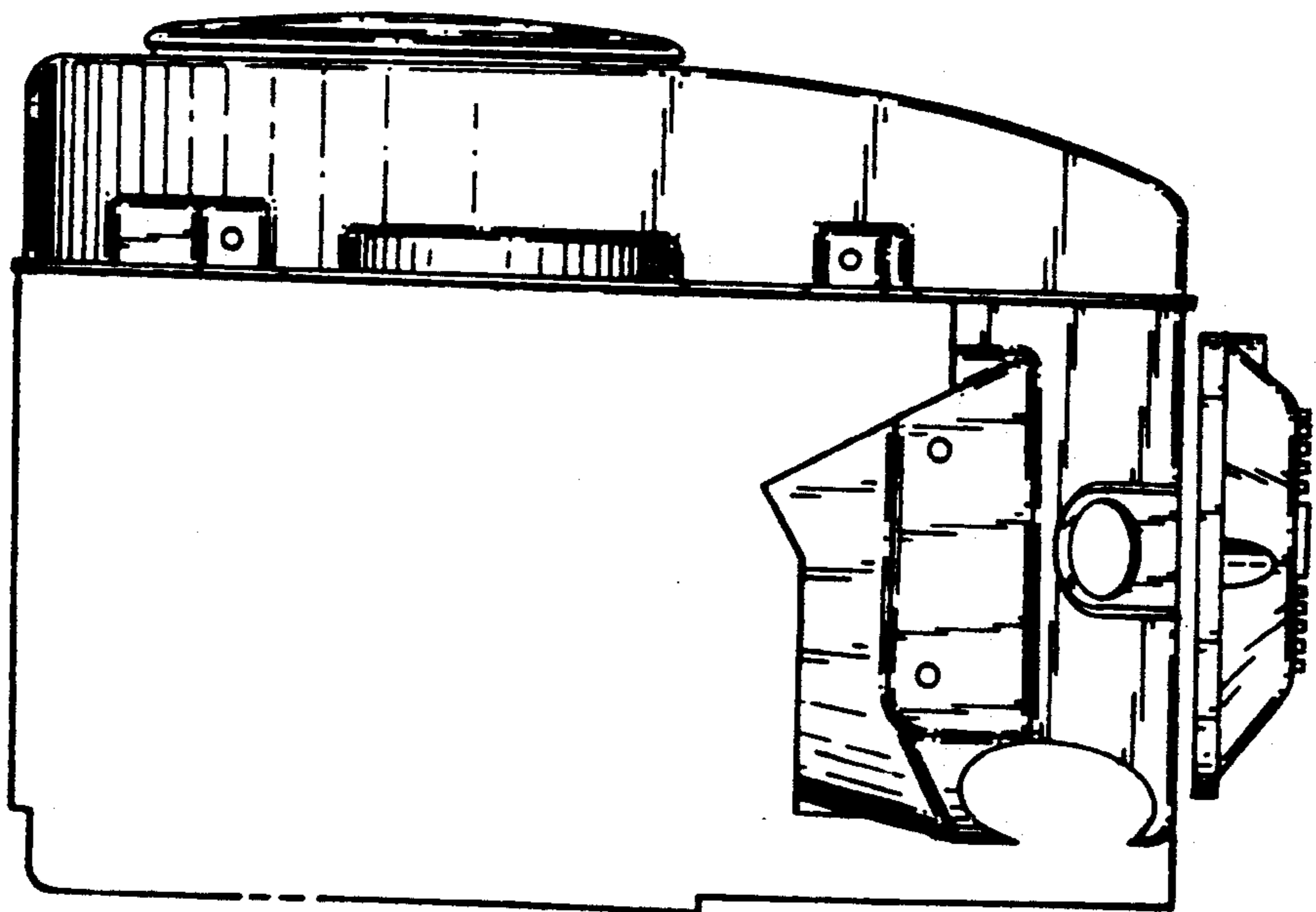

FIG. 7

