



US00D331904S

# United States Patent [19]

[11] Patent Number: **Des. 331,904**

Maresca

[45] Date of Patent: **\*\* Dec. 22, 1992**

[54] CAR MAT

[76] Inventor: **Rocco Maresca**, 1131 Camanche Ave., Clinton, Iowa 52732

[\*\*] Term: **14 Years**

[21] Appl. No.: **773,301**

[22] Filed: **Oct. 9, 1991**

[52] U.S. Cl. .... **D12/203**

[58] Field of Search ..... **D12/203; D6/582; 15/215, 217; 296/97.23; 428/85**

[56] **References Cited**

**U.S. PATENT DOCUMENTS**

D. 87,622	8/1932	Cohen .....	D12/185
1,680,442	8/1928	Anderson .....	296/97.23
4,435,451	3/1984	Neubert .....	428/88
4,804,567	2/1989	Reuben .....	428/88
4,871,602	10/1989	Luker .....	428/88
4,955,658	9/1990	Graves .....	296/97.23

**FOREIGN PATENT DOCUMENTS**

2062861 6/1971 France .  
2547252 12/1984 France .

*Primary Examiner*—James M. Gandy  
*Attorney, Agent, or Firm*—Terry M. Gernstein

[57] **CLAIM**

The ornamental design for a car mat, as shown and described.

**DESCRIPTION**

FIG. 1 is a perspective view of the car mat embodying the design of the present invention; FIG. 2 is a front elevational view thereof; FIG. 3 is a rear elevational view thereof; FIG. 4 is a side elevational view thereof, the side opposite being a mirror image of the side shown in FIG. 4; FIG. 5 is a top plan view thereof; and, FIG. 6 is a bottom view thereof.

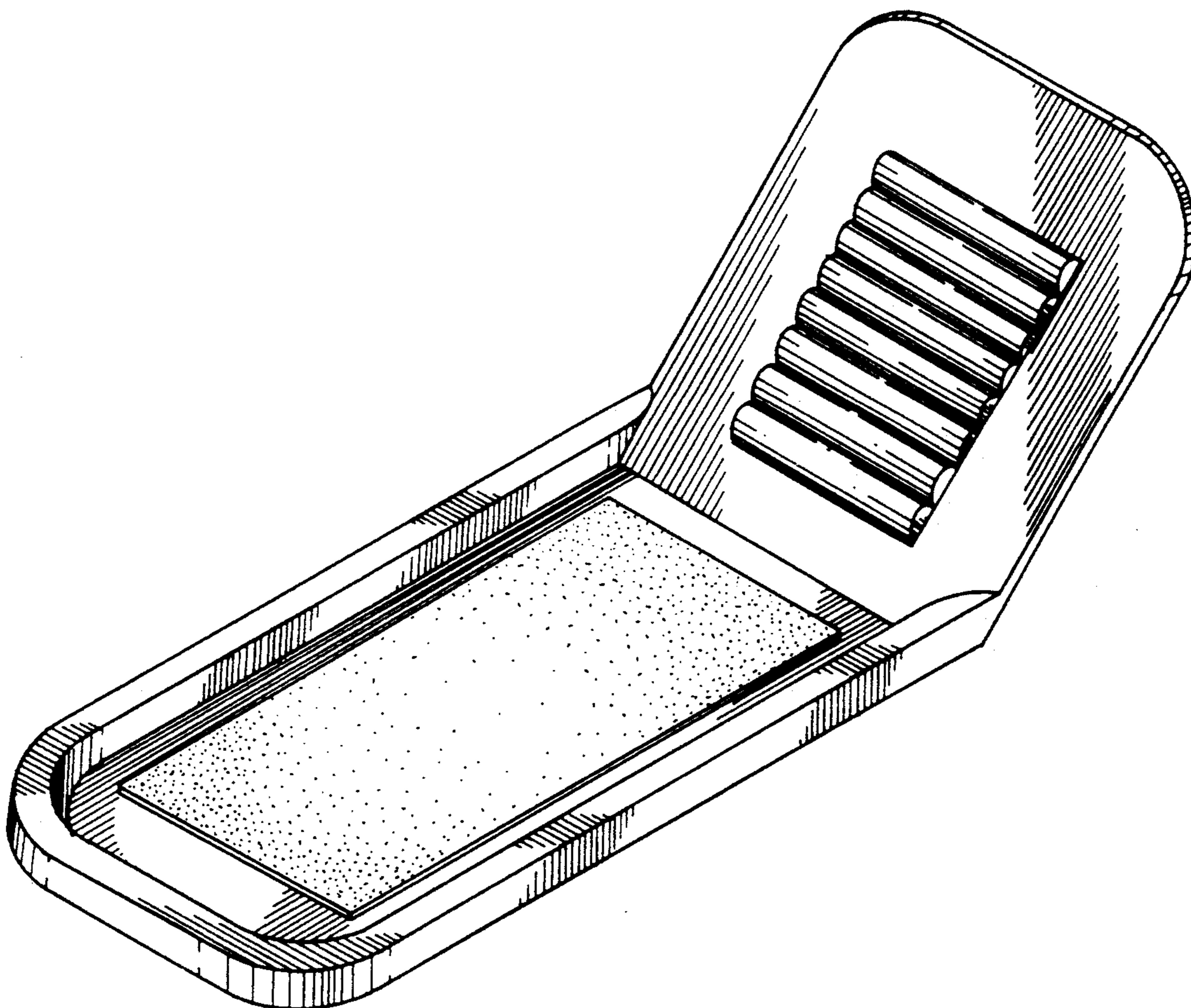

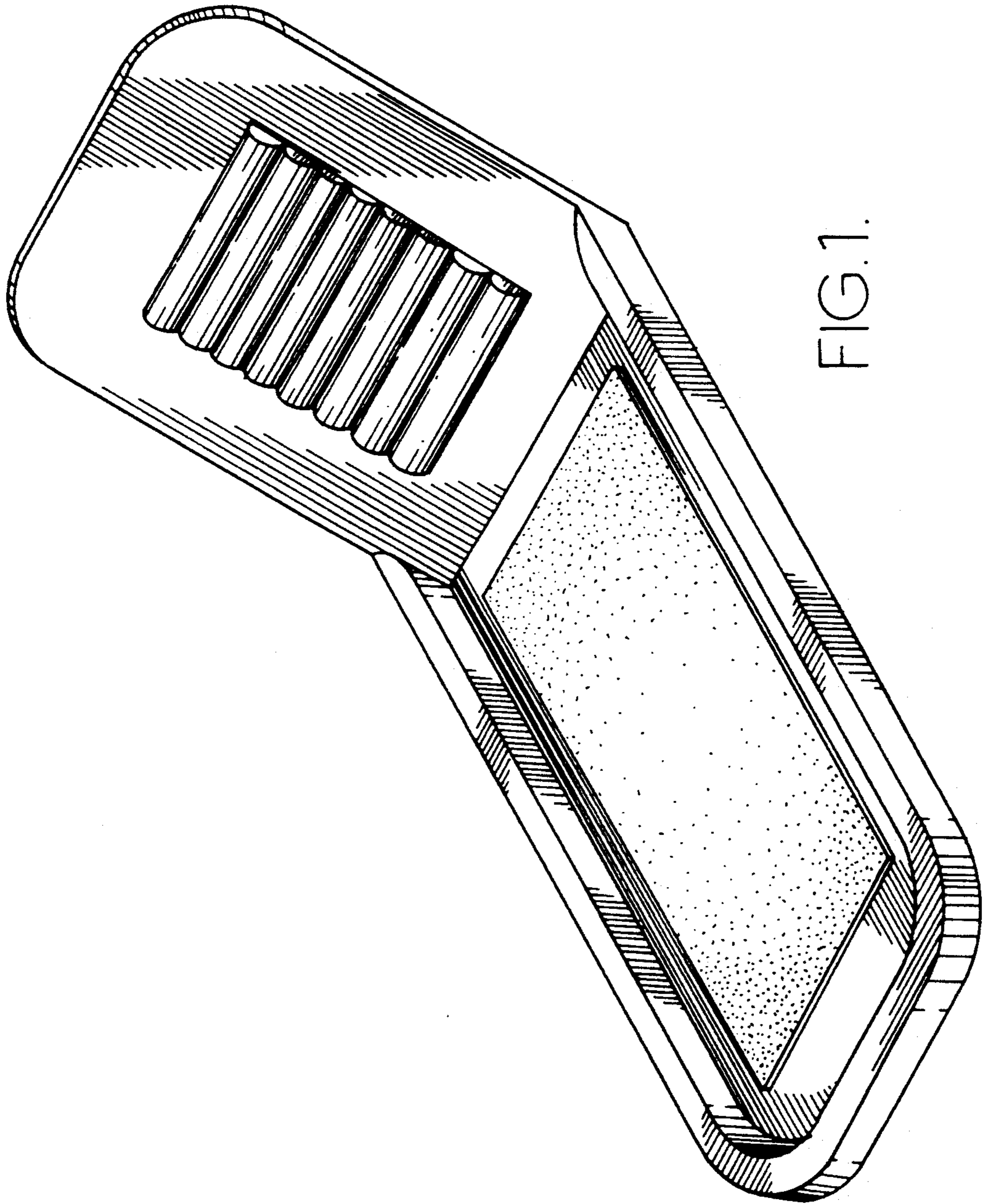

FIG. 1.

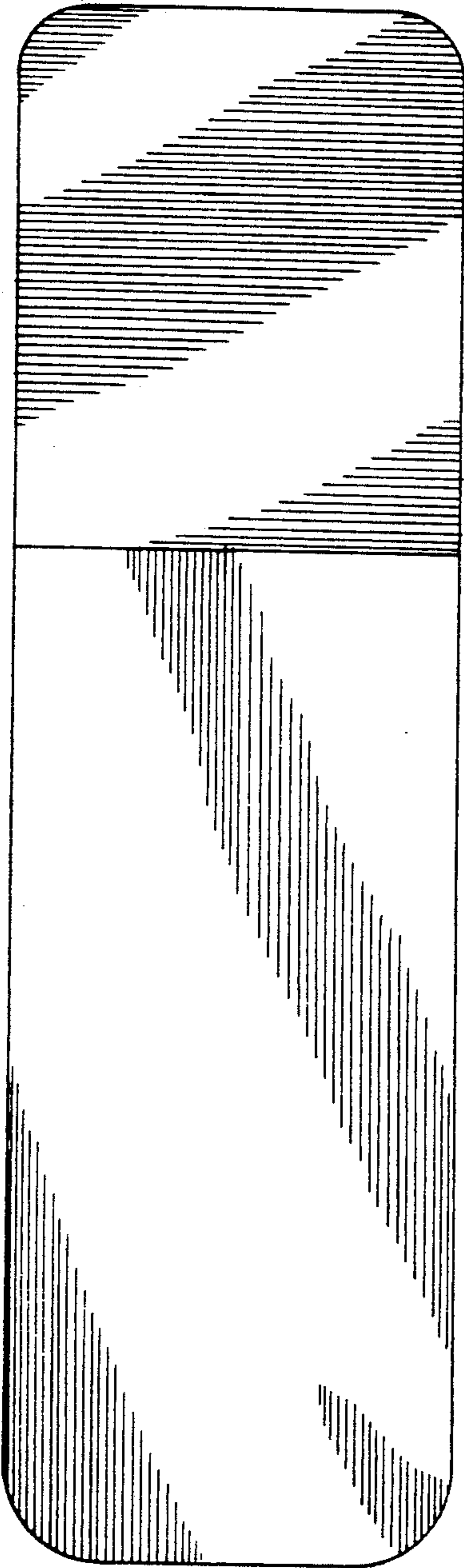

FIG. 6.

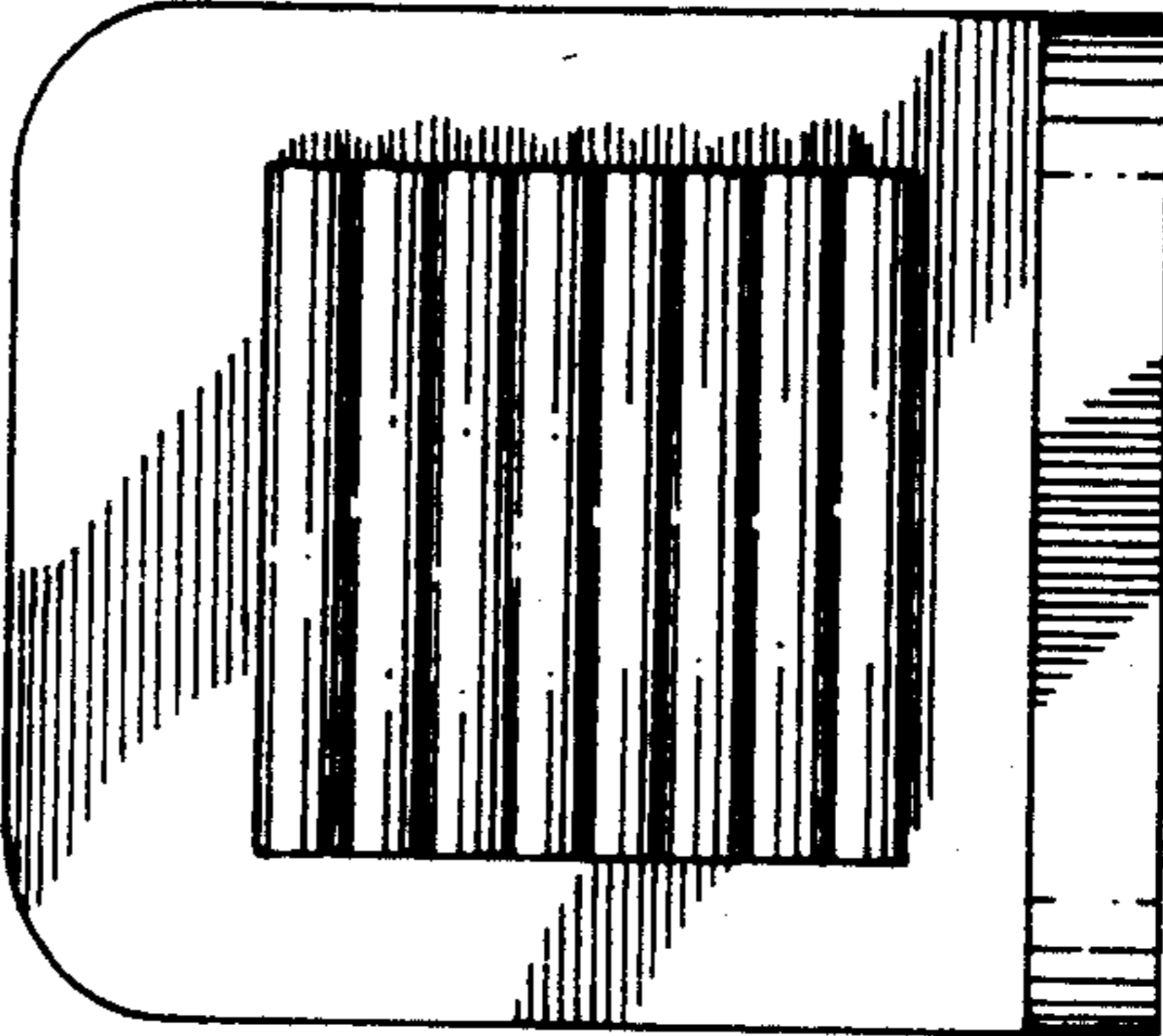

FIG. 2.

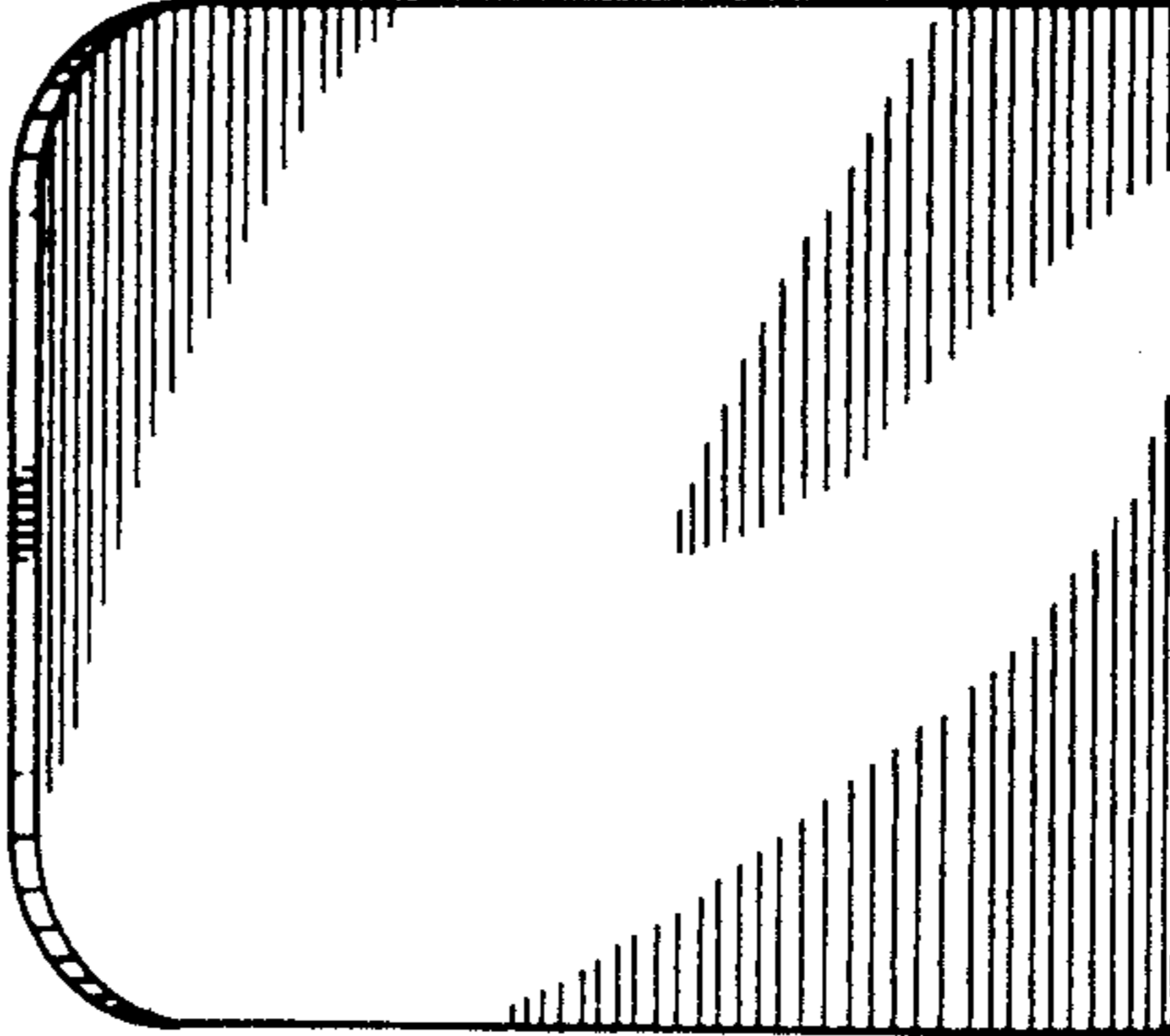

FIG. 3.

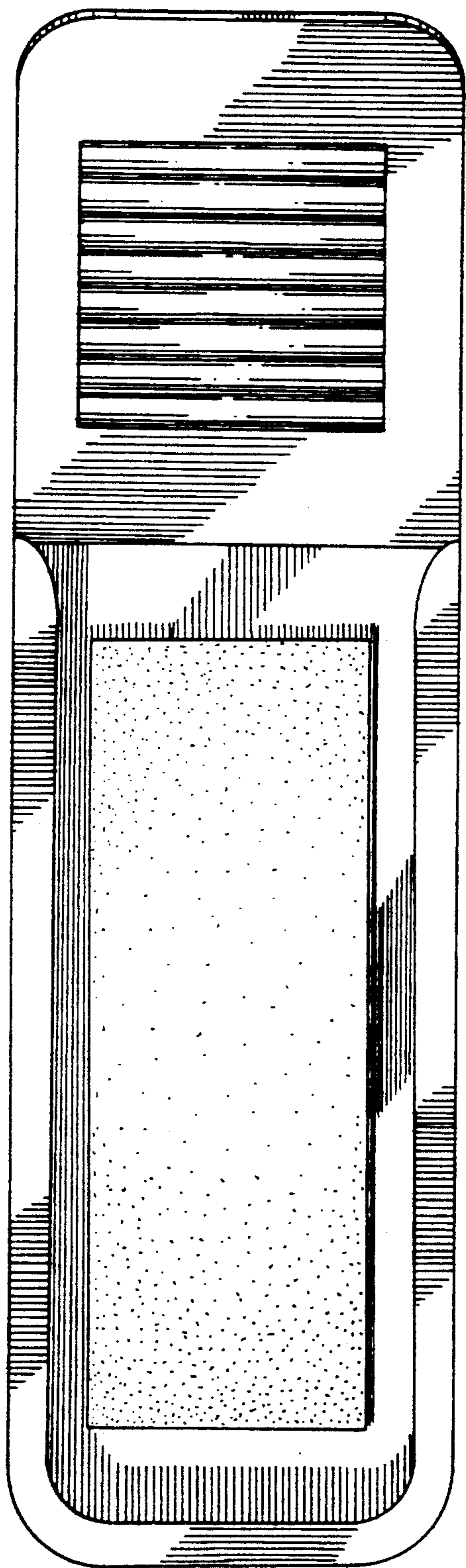

FIG. 5.

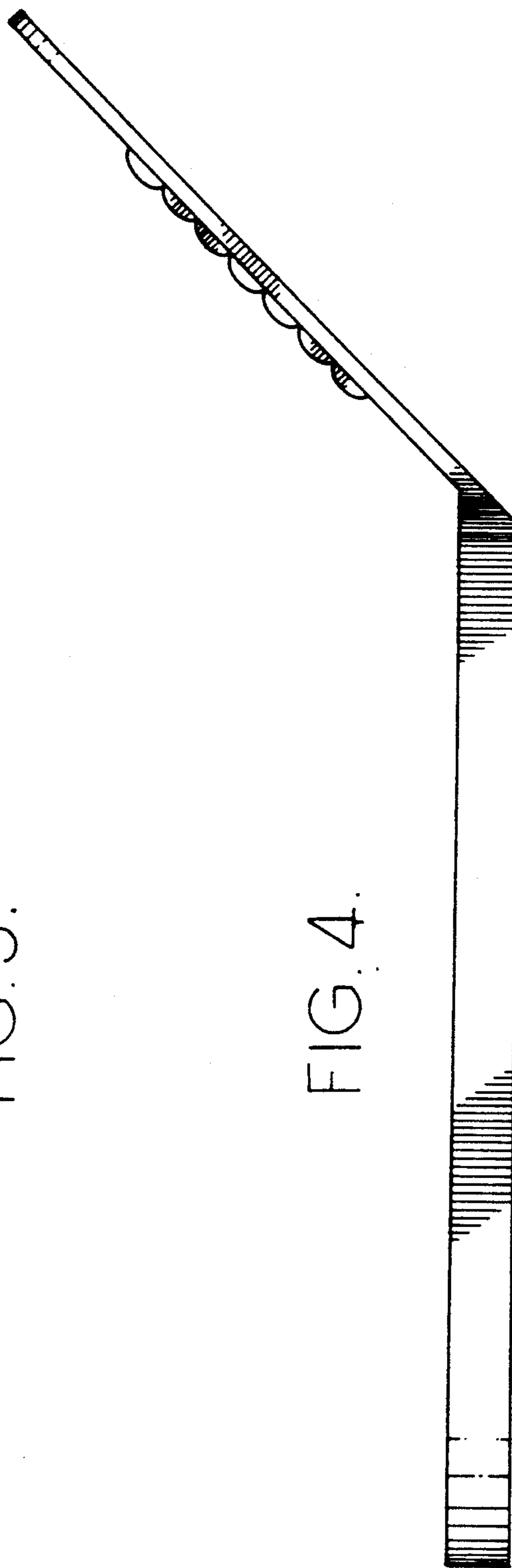

FIG. 4.