



US00D331694S

United States Patent [19]

Wang

[11] Patent Number: **Des. 331,694**

[45] Date of Patent: **** Dec. 15, 1992**

[54] **AUTOMOBILE STEERING WHEEL LOCK**

[76] Inventor: **Ching-Rong Wang**, No. 27, Alley 74,
Lane 313, Wen-Hsien Road, Tainan,
Taiwan

[**] Term: **14 Years**

[21] Appl. No.: **643,079**

[22] Filed: **Jan. 18, 1991**

[52] U.S. Cl. **D8/331**

[58] Field of Search **D8/330-331,**
D8/336, 338-339, 341-342; 70/207-211,
214-215, 225-226, 237-238; 292/289

4,935,047 6/1990 Wu 70/238 X
5,062,282 11/1991 Rong 70/211 X

Primary Examiner—Brian N. Vinson
Attorney, Agent, or Firm—Bacon & Thomas

[57] CLAIM

The ornamental design for an automobile steering wheel lock, as shown.

DESCRIPTION

FIG. 1 is a top, front, and left side perspective view of an automobile steering wheel lock showing my new design;

FIG. 2 is a front elevational view thereof;
FIG. 3 is a rear elevational view thereof;
FIG. 4 is a left side elevational view thereof;
FIG. 5 is a right side elevational view thereof;
FIG. 6 is a top plan view thereof; and,
FIG. 7 is a bottom plan view thereof.

[56] References Cited

U.S. PATENT DOCUMENTS

D. 289,491 4/1987 Johnson D8/330
D. 312,202 11/1990 Wang D8/331 X
4,738,127 4/1988 Johnson 70/209

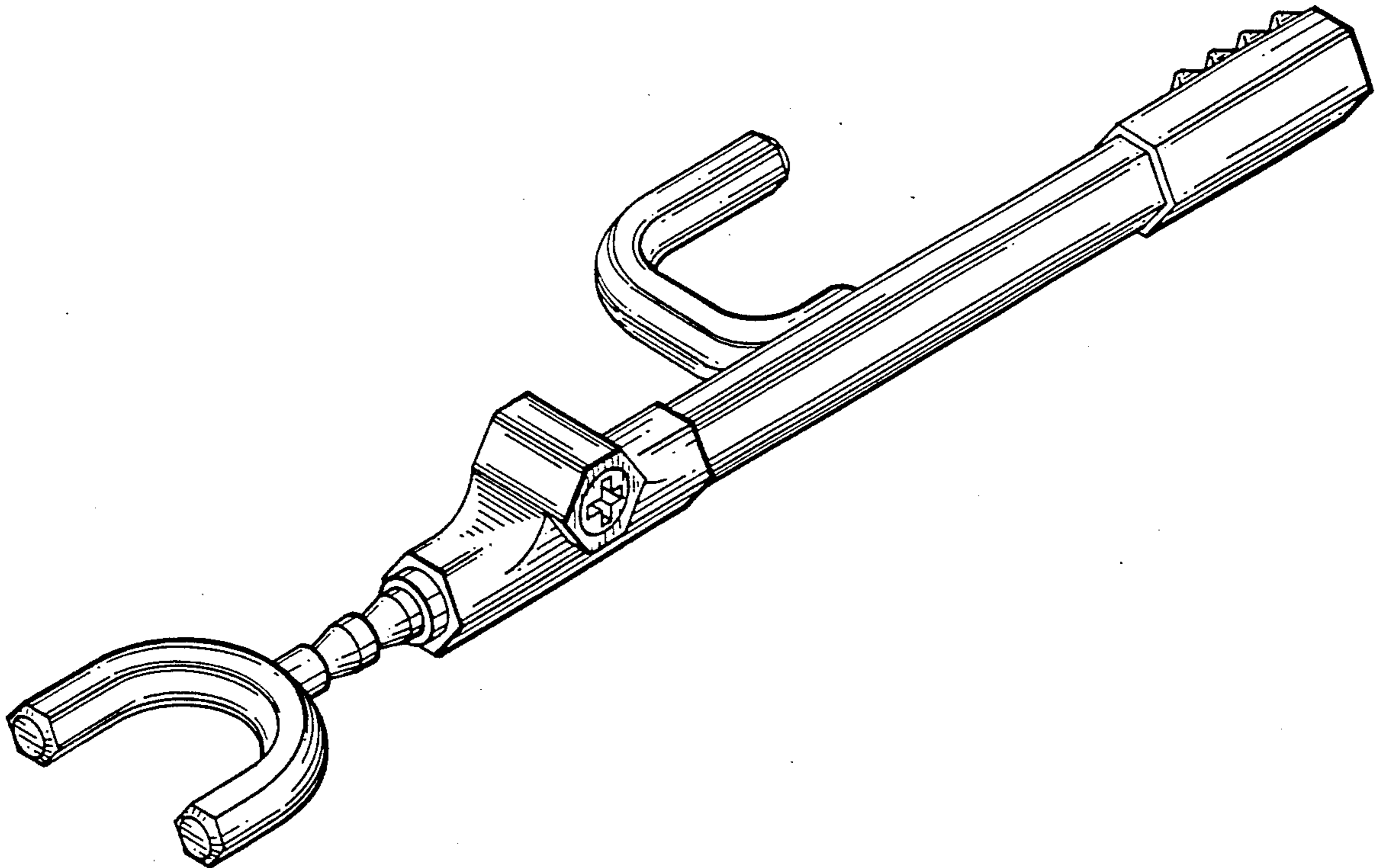

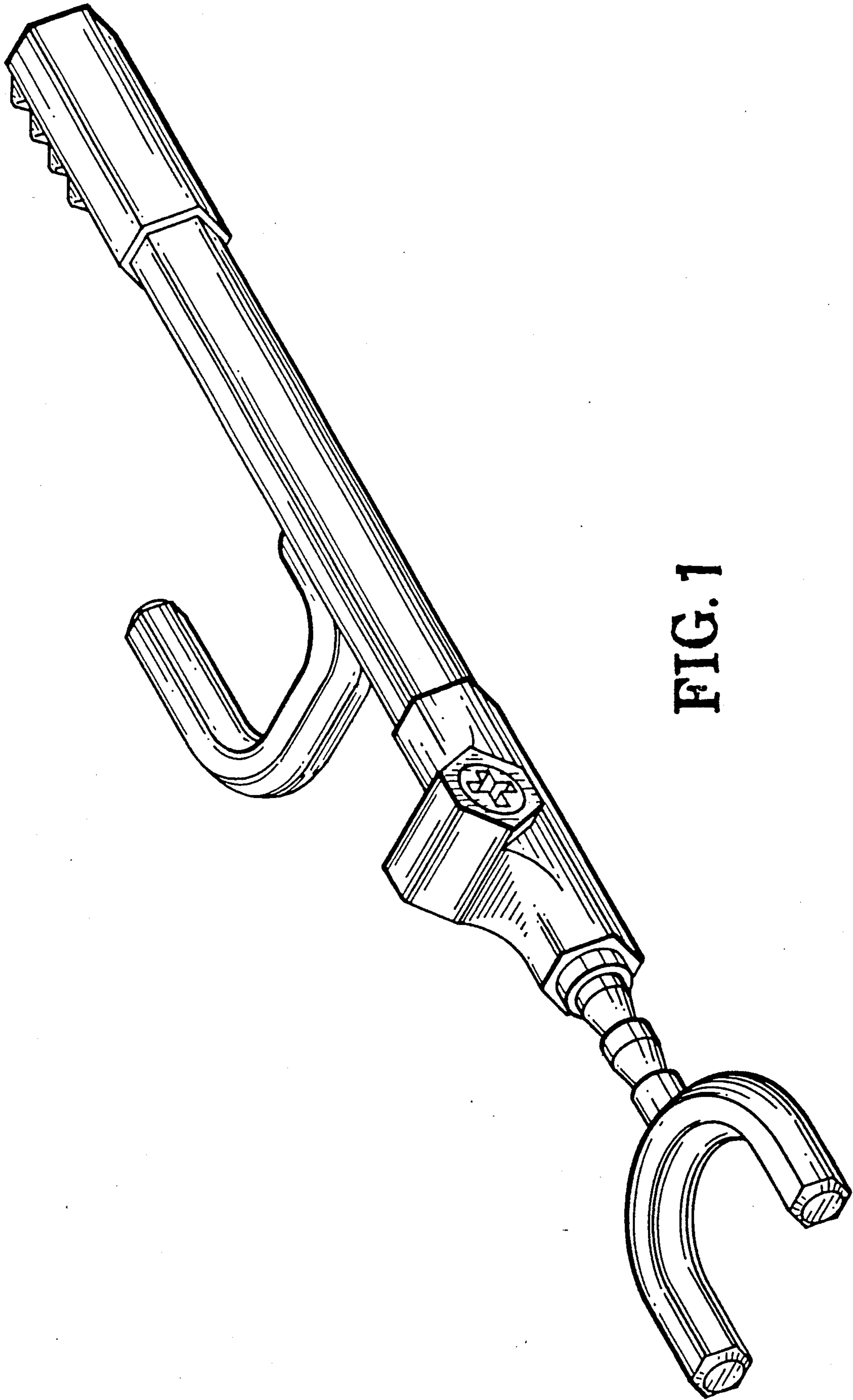

FIG. 1

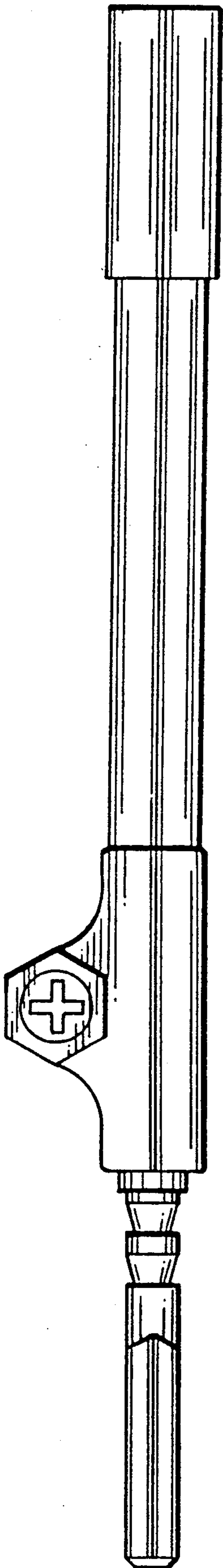

FIG. 2

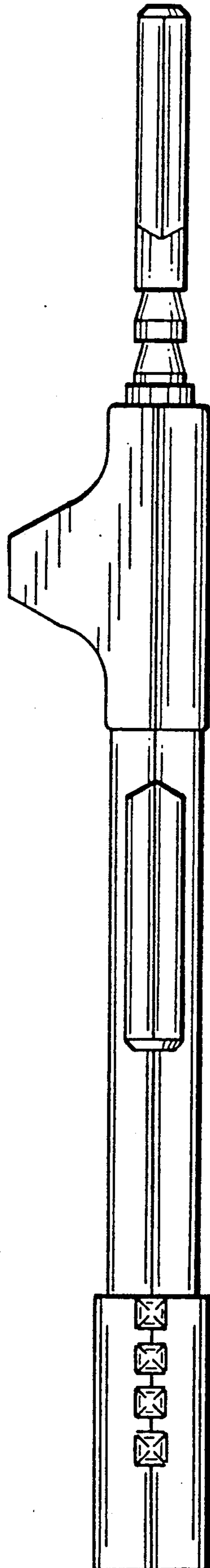

FIG. 3

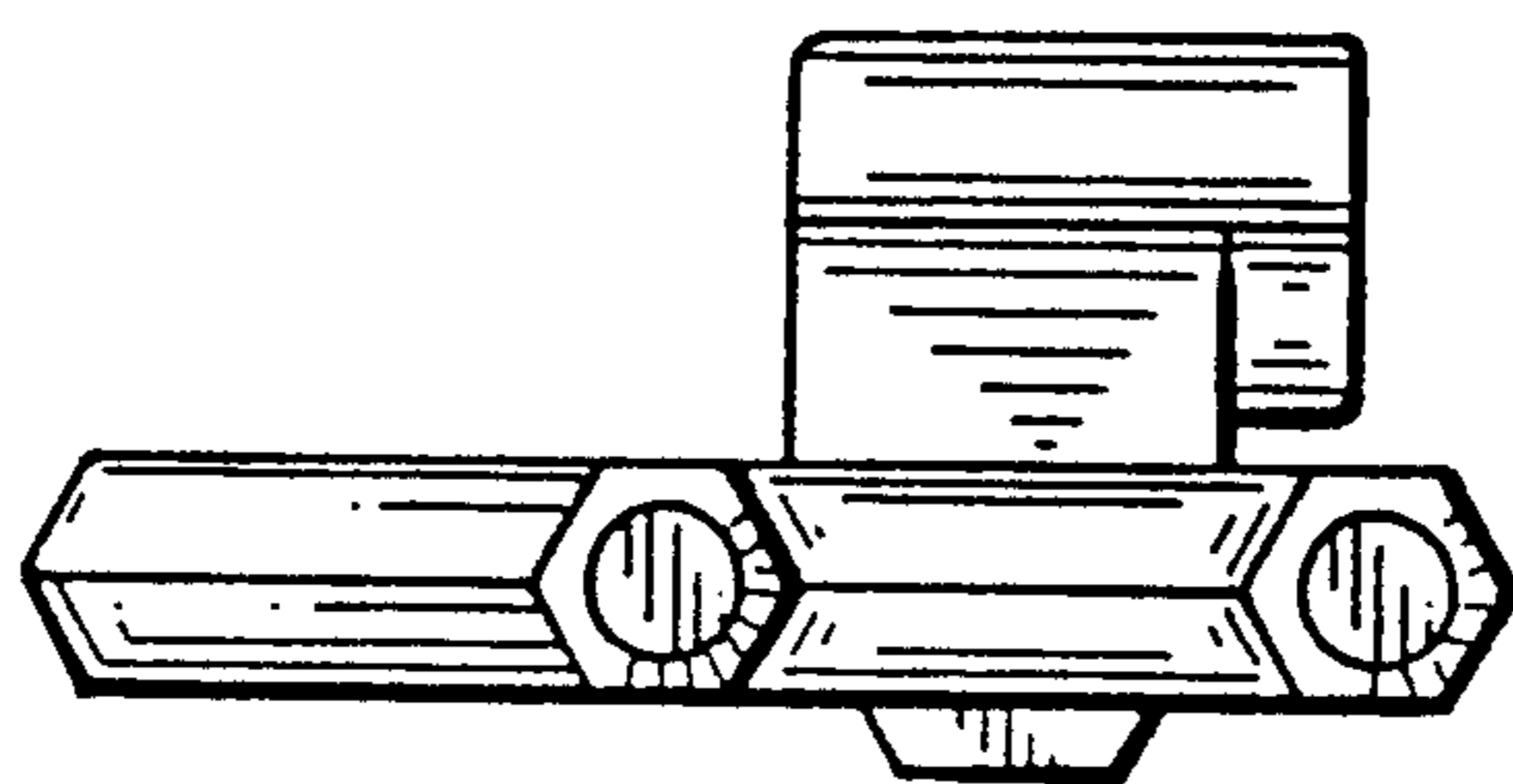

FIG. 4

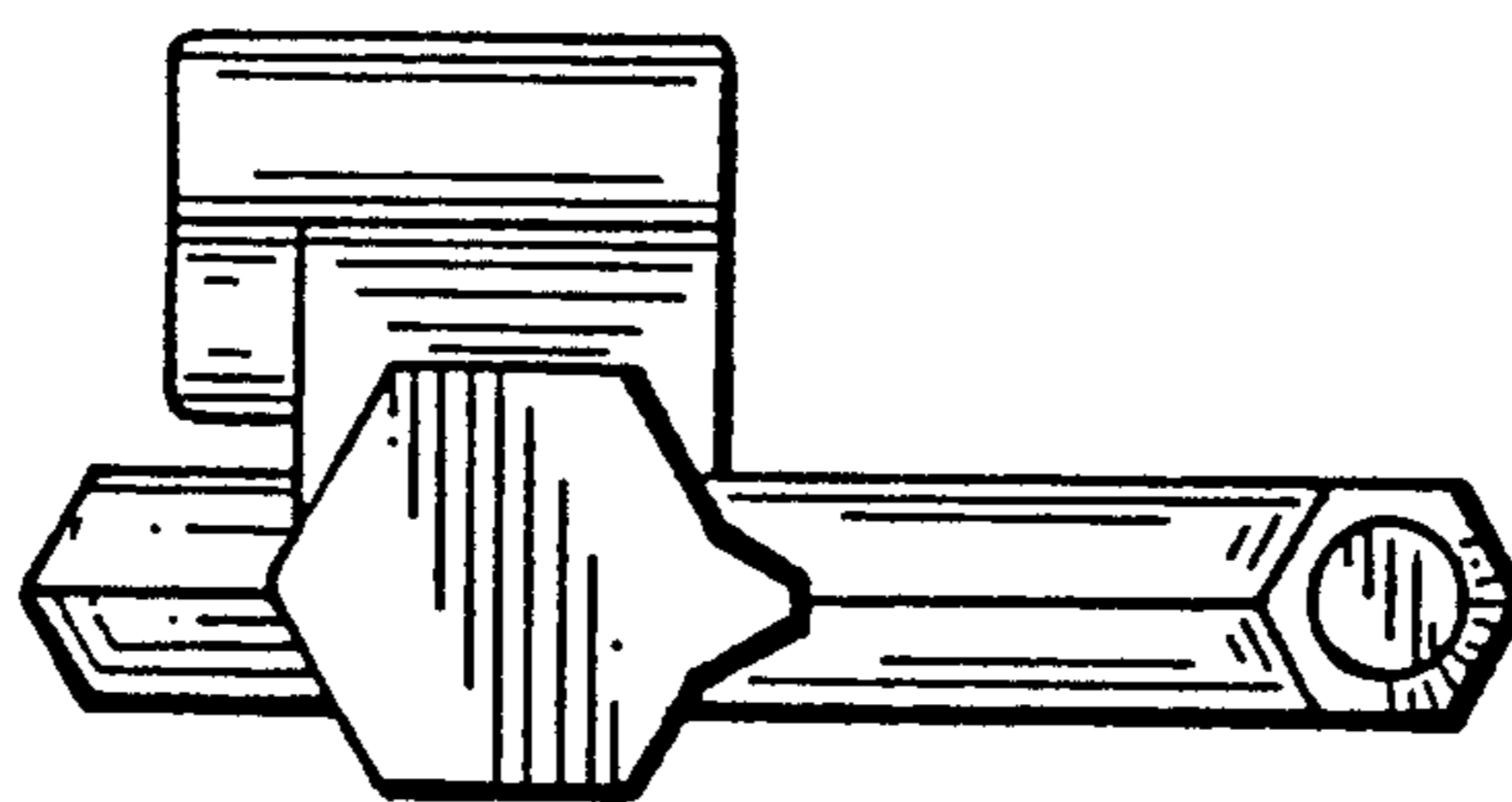

FIG. 5

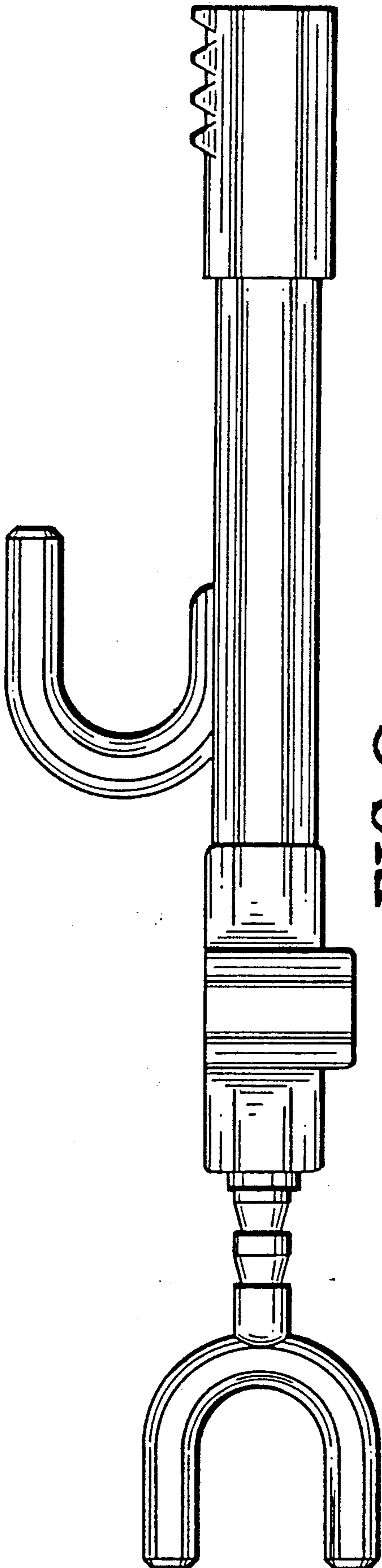

FIG. 6

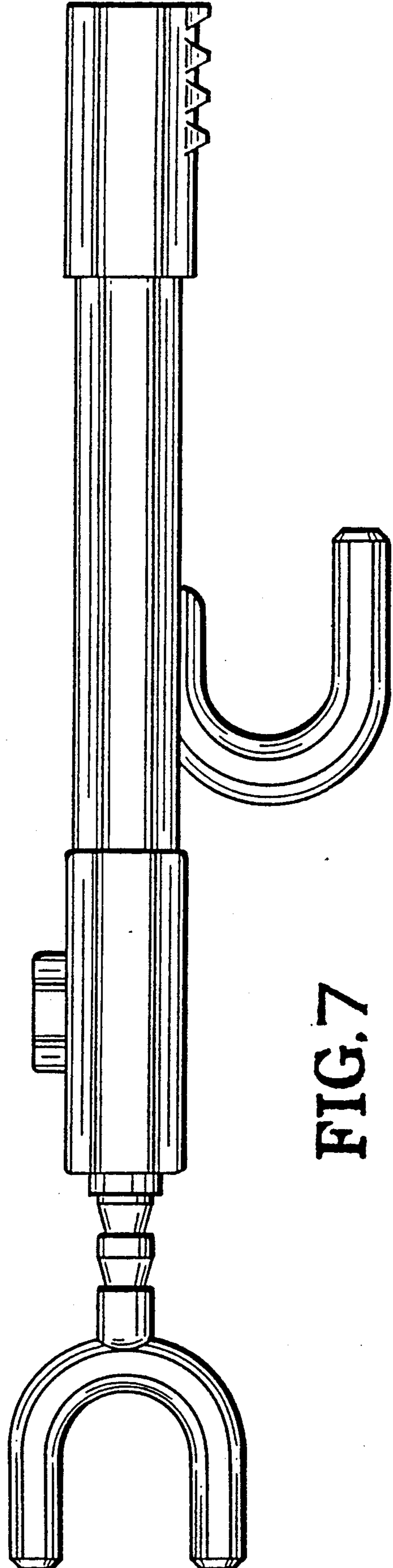

FIG. 7