



US00D331652S

United States Patent [19]

Wu

[11] Patent Number: **Des. 331,652**

[45] Date of Patent: **** Dec. 8, 1992**

- [54] **GOLF CART HANDLEBAR**
- [76] Inventor: **Ching-Chang Wu**, No. 35-1, Jih Hsin Street, Tu Cheng Hsiang, Taipei Hsien, Taiwan
- [**] Term: **14 Years**
- [21] Appl. No.: **670,802**
- [22] Filed: **Mar. 19, 1991**
- [52] U.S. Cl. **D34/27; D8/10; D12/178**
- [58] Field of Search **D12/16, 174, 178; D8/DIG. 7, 10, 11; D34/15, 27; 294/57; 280/646, DIG. 5, DIG. 6**

- 4,913,460 4/1990 Klein D34/15
- 5,074,577 12/1991 Kim 280/646
- 5,109,938 5/1992 Vautelin et al. 280/DIG. 6

OTHER PUBLICATIONS

Wagner Brochure, Dec. 21, 1948, the Deluxe Golf Cart.

Primary Examiner—Wallace R. Burke
Assistant Examiner—Melody Brown
Attorney, Agent, or Firm—Varndell Legal Group

[57] CLAIM

The ornamental design for golf cart handlebar, as shown and described.

DESCRIPTION

FIG. 1 is a perspective view of a golf cart handlebar showing my new design;
 FIG. 2 is a front elevational view thereof;
 FIG. 3 is a side elevational view thereof, the opposite side being a mirror image of that shown;
 FIG. 4 is a rear elevational view thereof;
 FIG. 5 is a top plan view thereof; and,
 FIG. 6 is a bottom plan view thereof.

[56] References Cited

U.S. PATENT DOCUMENTS

- 284,733 7/1986 Hozumi D8/10
- 2,579,484 12/1951 Fenton D8/10
- 2,687,895 8/1954 Rutledge 280/DIG. 6
- 3,265,106 8/1966 Jarman 280/DIG. 6
- 4,639,029 1/1987 Kolonia 294/57

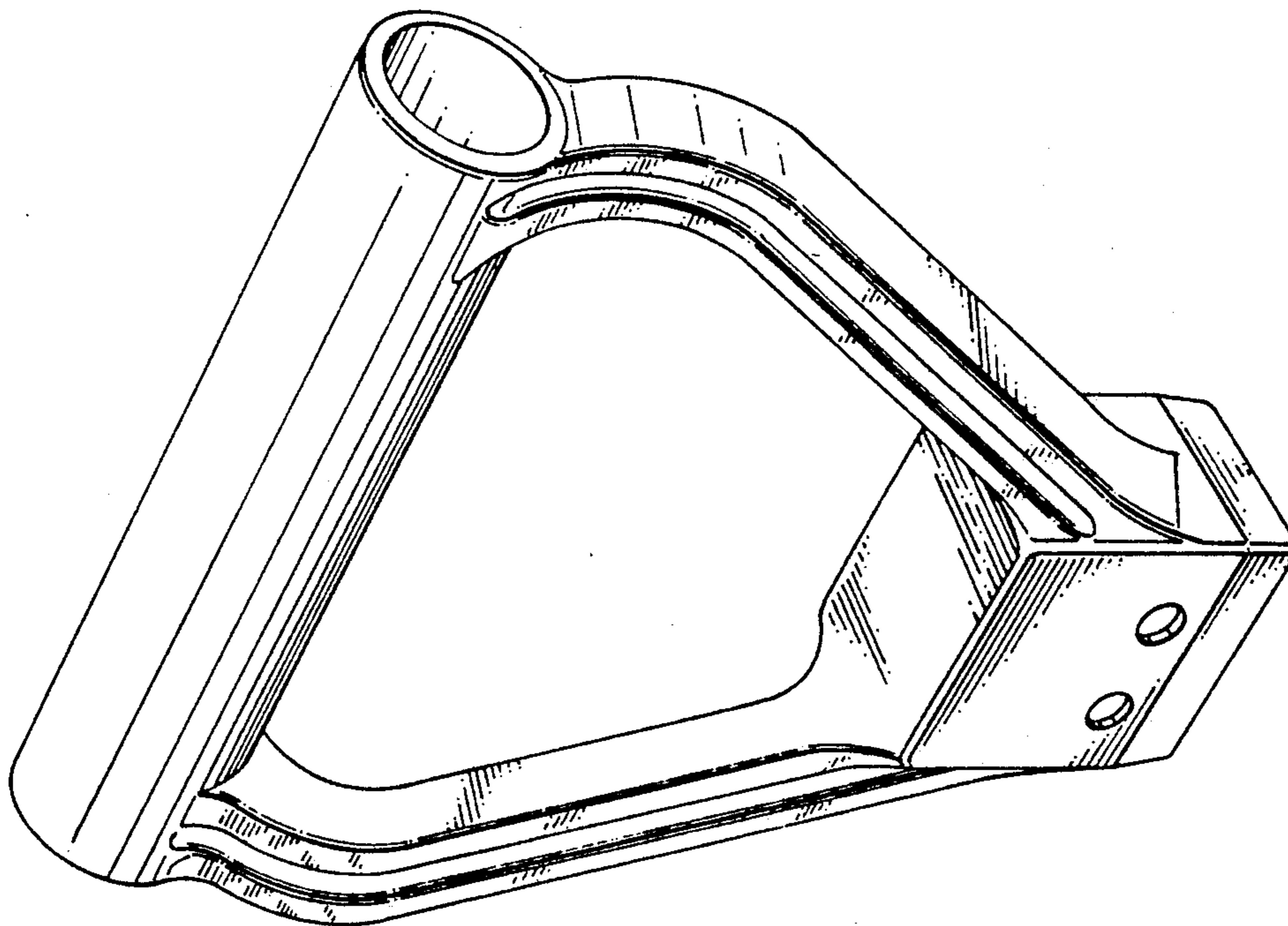

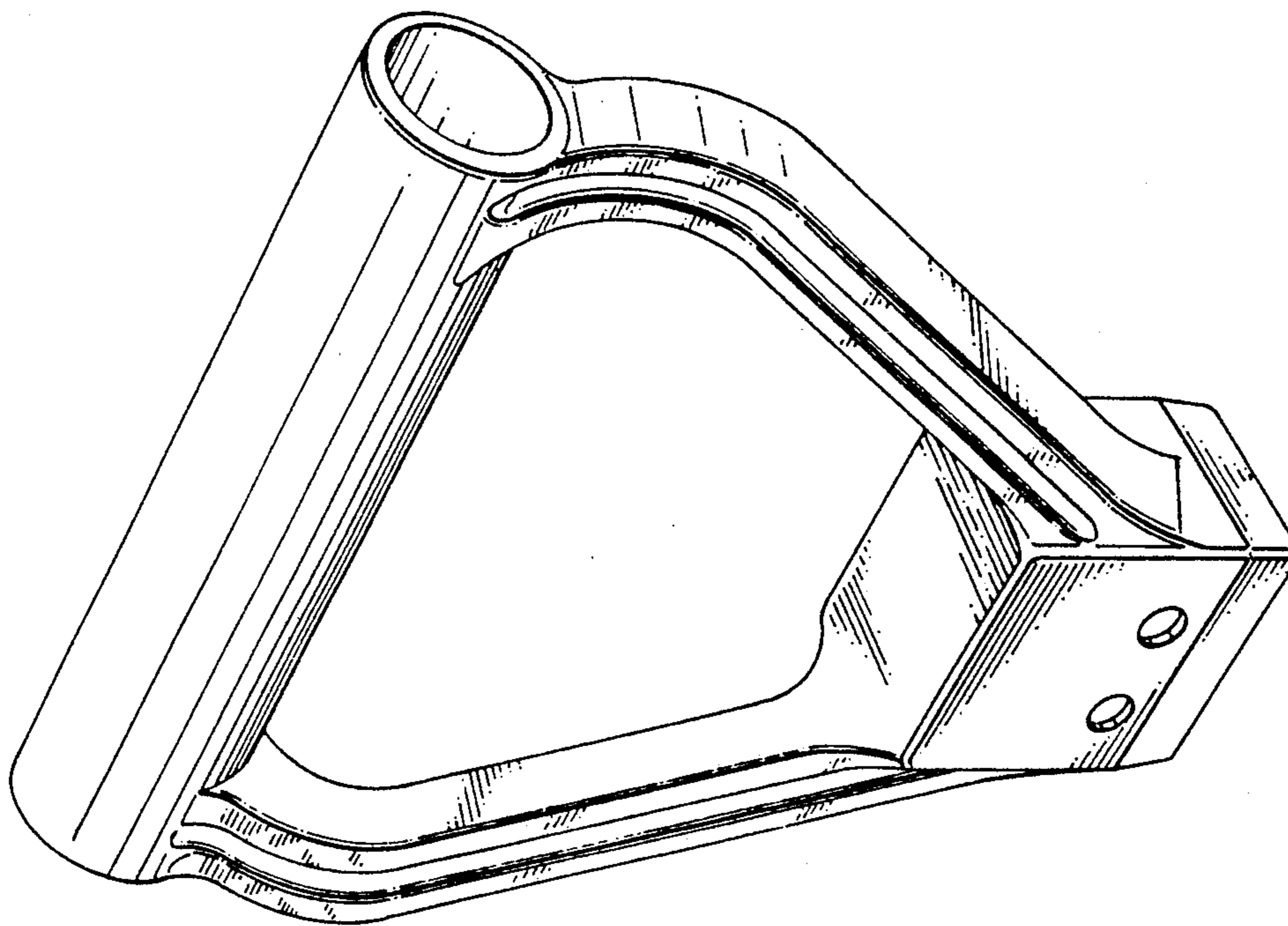

Fig. 1

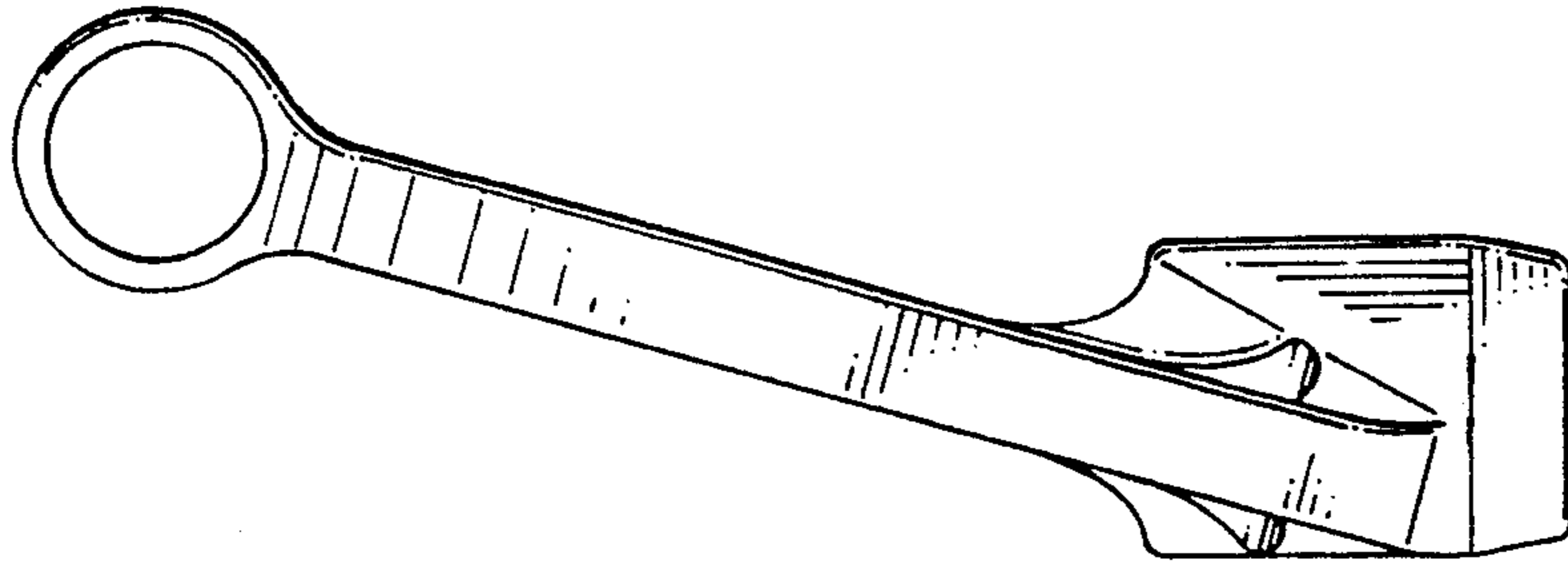

Fig. 3

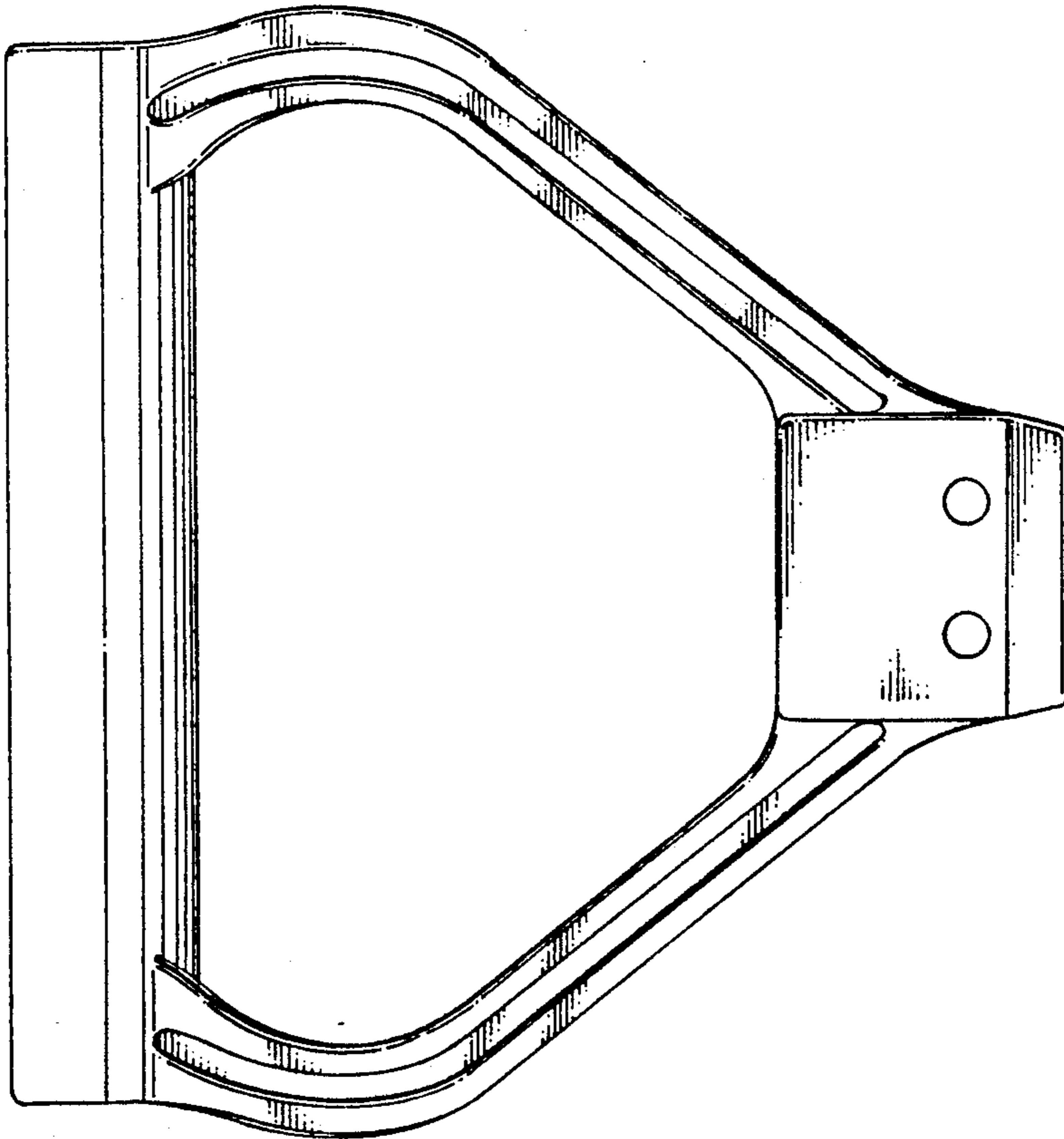

Fig. 2

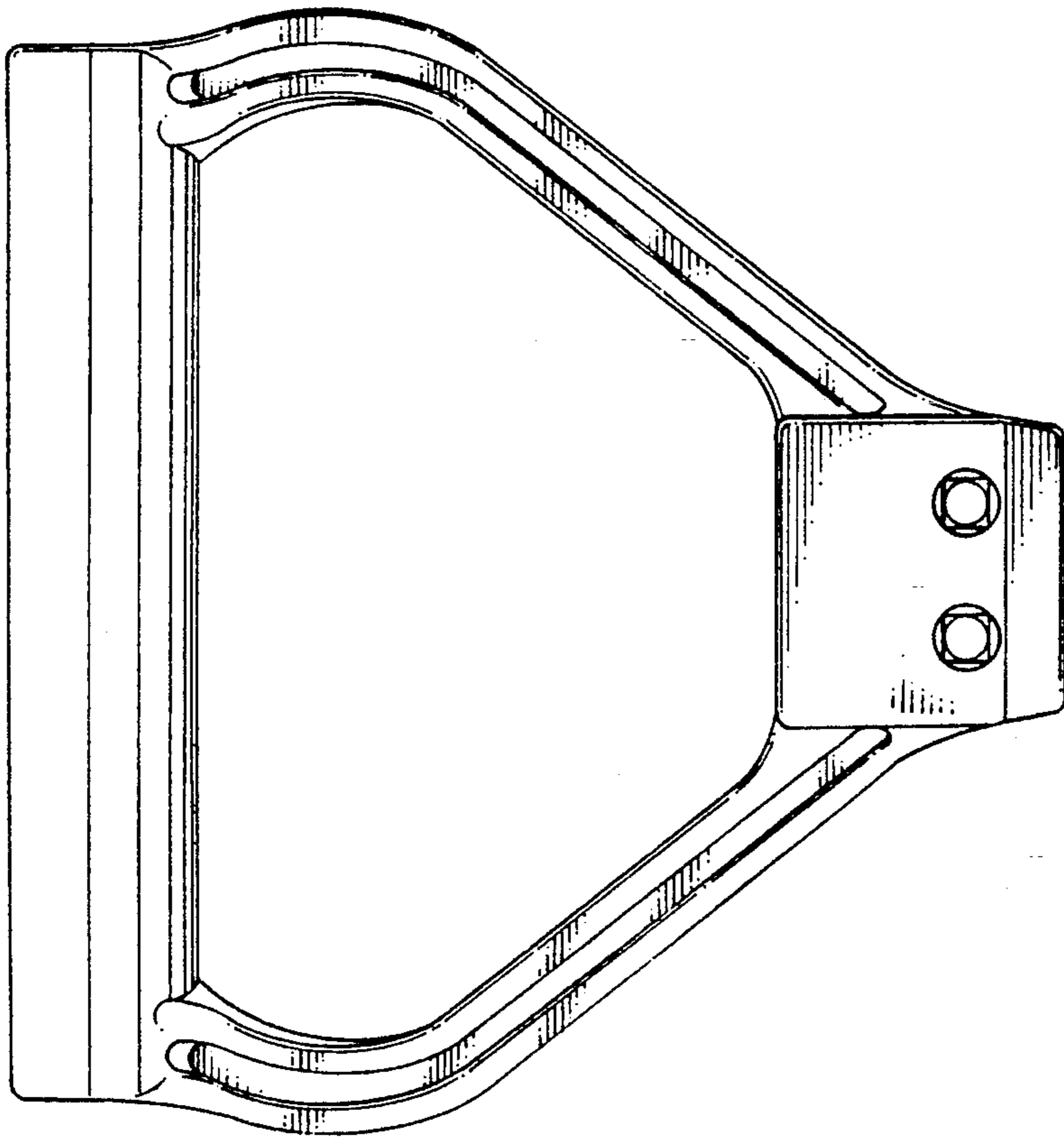

Fig. 4

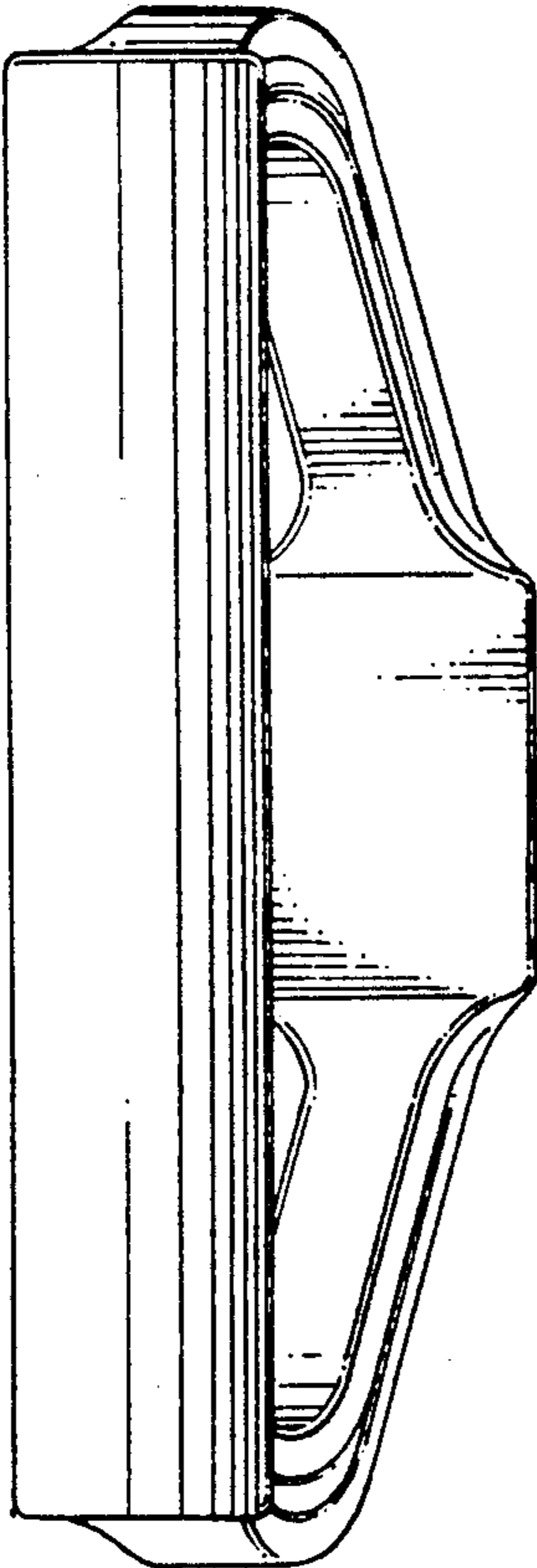

Fig. 5

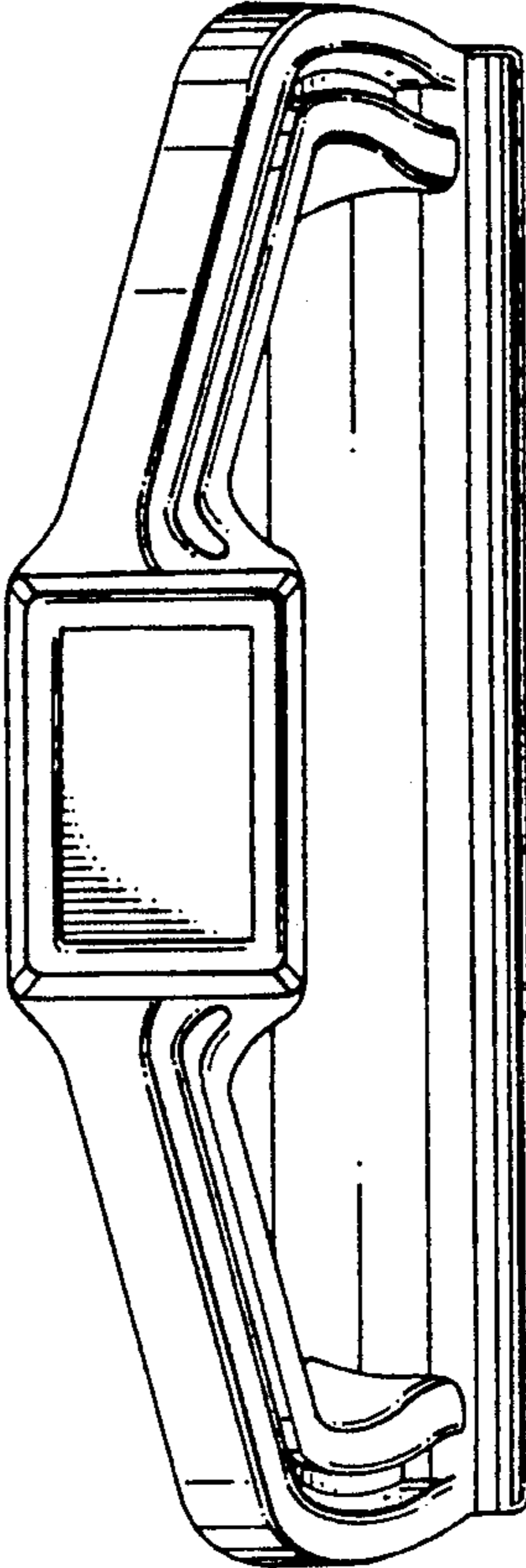

Fig. 6