



US00D331551S

United States Patent [19]

Warren, Sr. et al.

[11] Patent Number: **Des. 331,551**

[45] Date of Patent: **** Dec. 8, 1992**

[54] **GROUND EFFECTS VEHICLE**

[76] Inventors: **Cleland L. Warren, Sr.; Diane L. Warren**, both of 2519 Fern Palm, Edgewater, Fla. 32141

[**] Term: **14 Years**

[21] Appl. No.: **665,171**

[22] Filed: **Mar. 6, 1991**

[52] U.S. Cl. **D12/5**

[58] Field of Search **D12/5, 11; 180/116, 180/117, 118, 123, 125, 127**

4,643,268 2/1987 Jones 180/116
 4,843,969 7/1989 Chaffee 104/23.2
 5,067,189 11/1991 Weedling et al. 180/125

Primary Examiner—Wallace R. Burke
Assistant Examiner—Melody Brown
Attorney, Agent, or Firm—Terry M. Gernstein

[57] CLAIM

The ornamental design for a ground effects vehicle, as shown.

DESCRIPTION

FIG. 1 is a perspective view of a ground effects vehicle showing our new design;
 FIG. 2 is a front elevational view thereof;
 FIG. 3 is a rear elevational view thereof;
 FIG. 4 is a side elevational view thereof;
 FIG. 5 is an opposite side elevational view thereof;
 FIG. 6 is a top plan view thereof; and,
 FIG. 7 is a bottom plan view thereof.

[56] **References Cited**

U.S. PATENT DOCUMENTS

D. 220,979	6/1971	Belik	D12/11
3,270,827	9/1966	Mantde	180/116
4,046,215	9/1977	Hietanen et al.	180/116
4,350,107	9/1982	Mattox	114/67 A
4,417,639	11/1983	Wegener	180/125

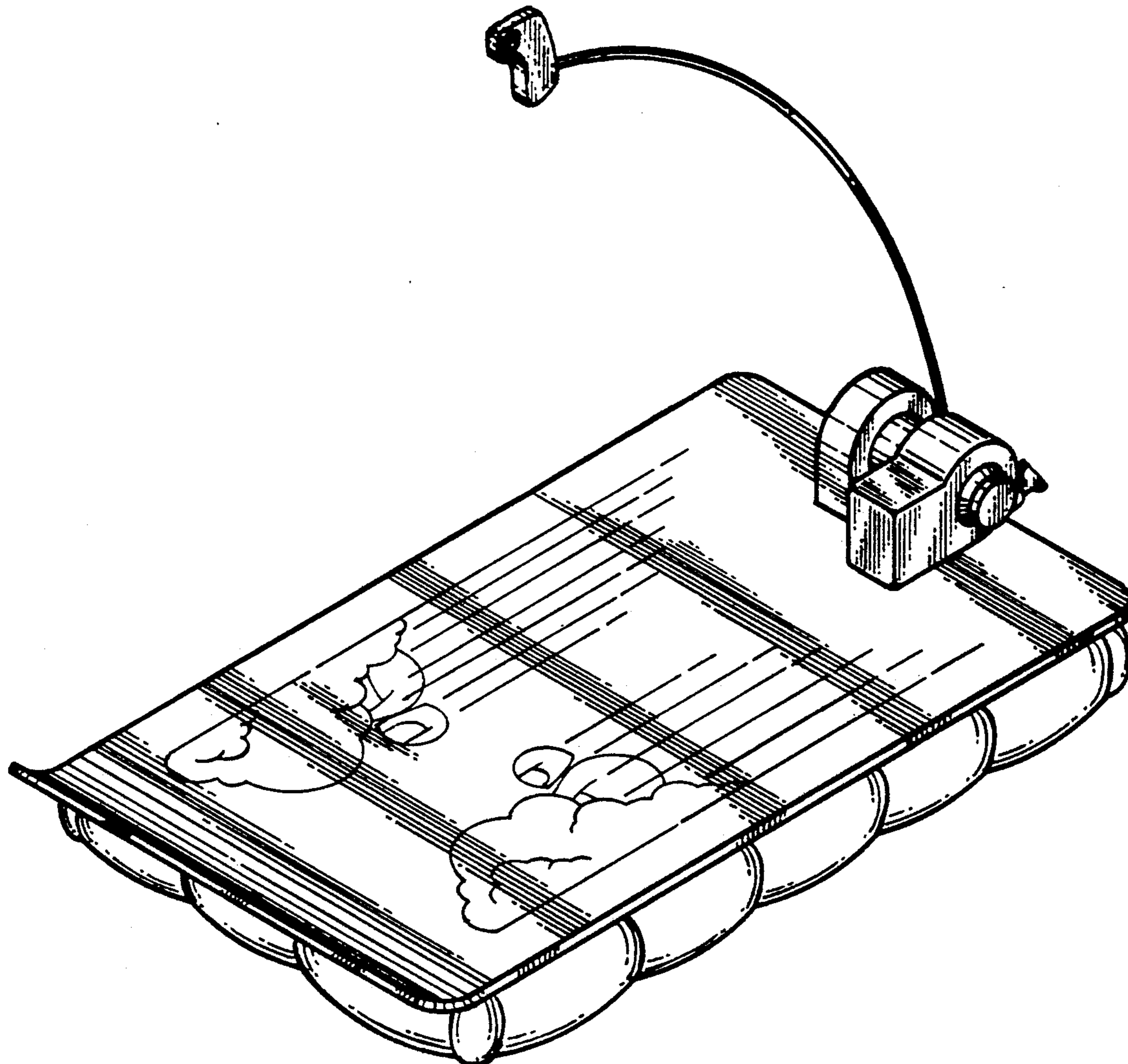

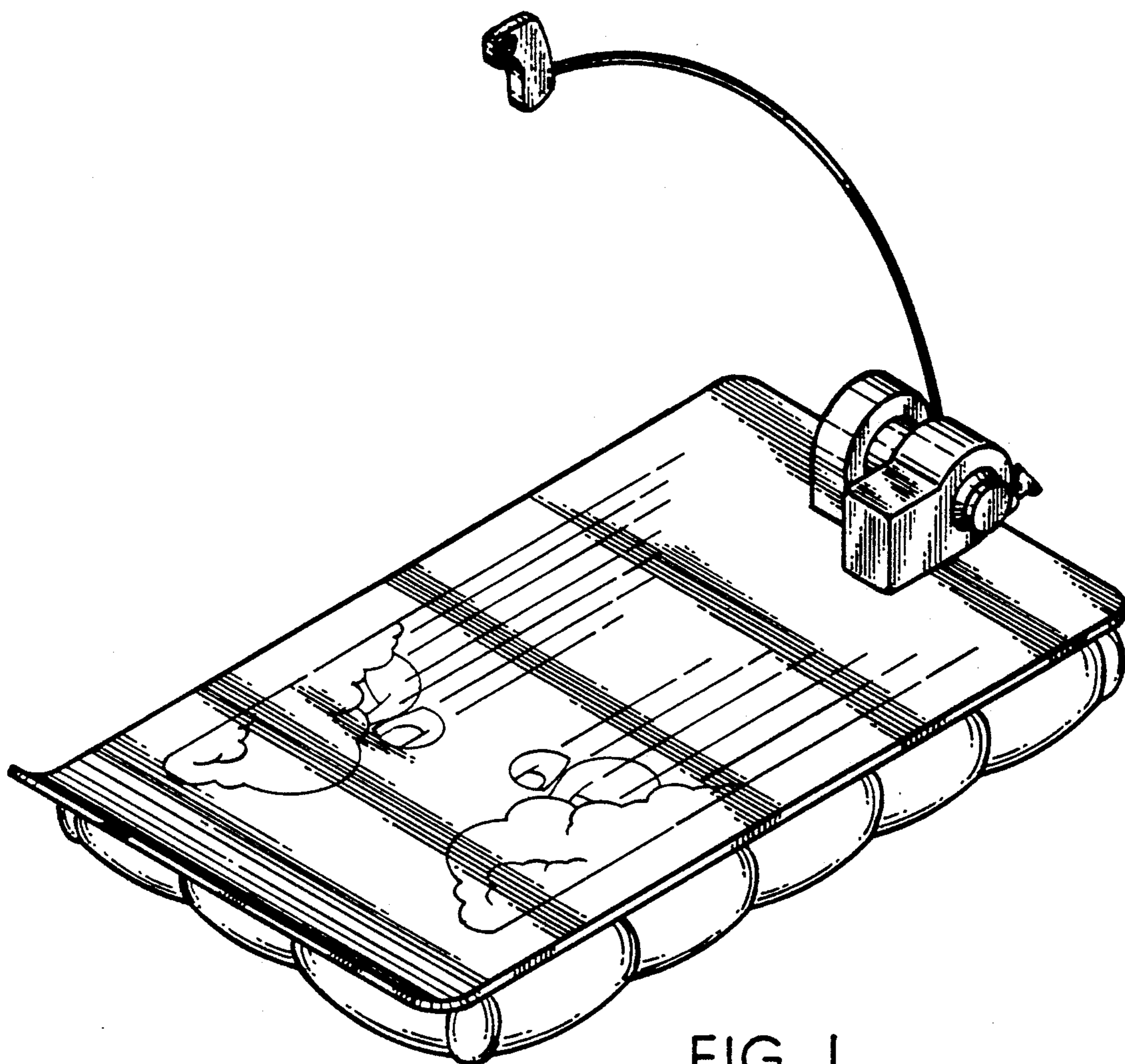

FIG. 1

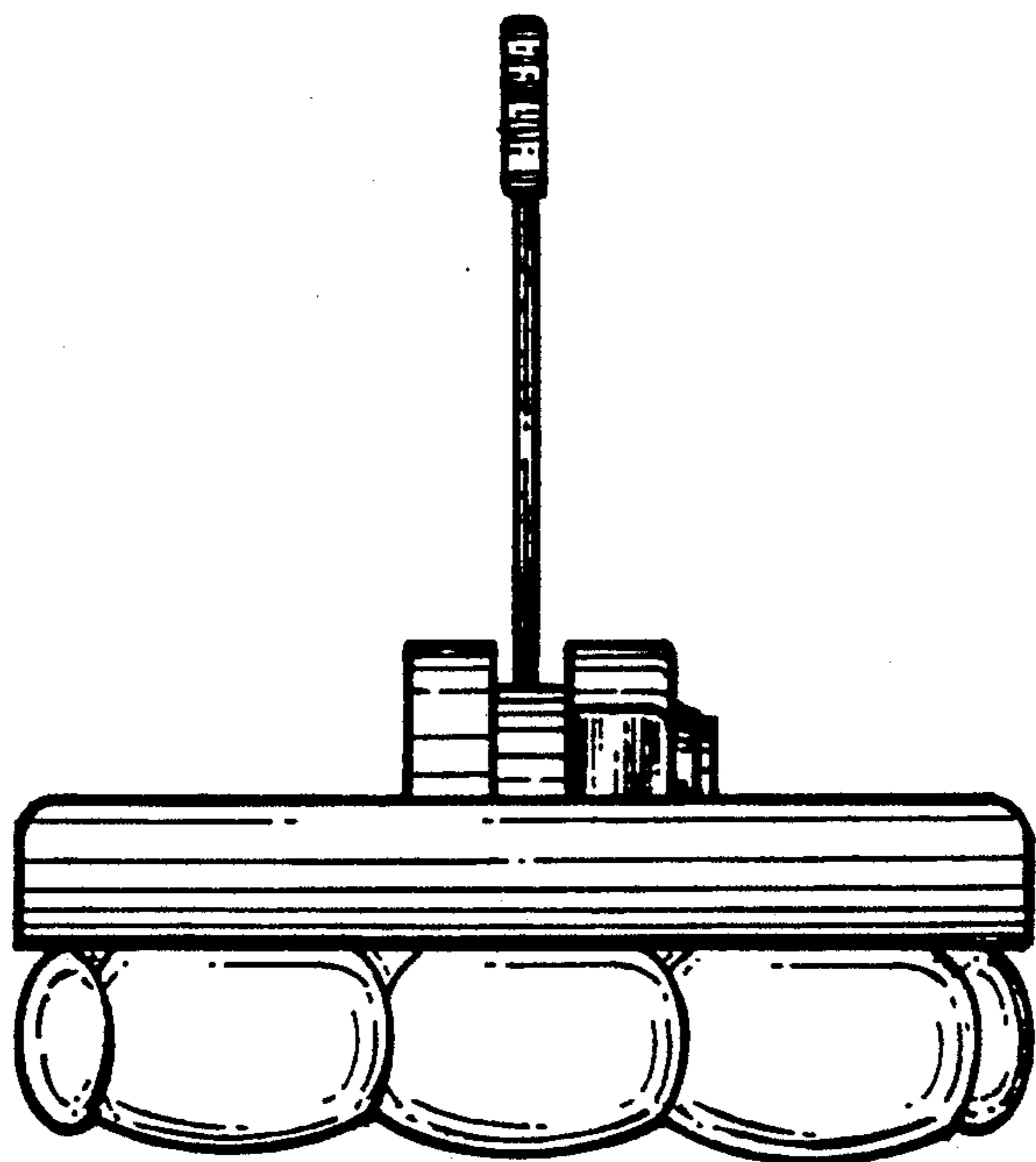

FIG. 2

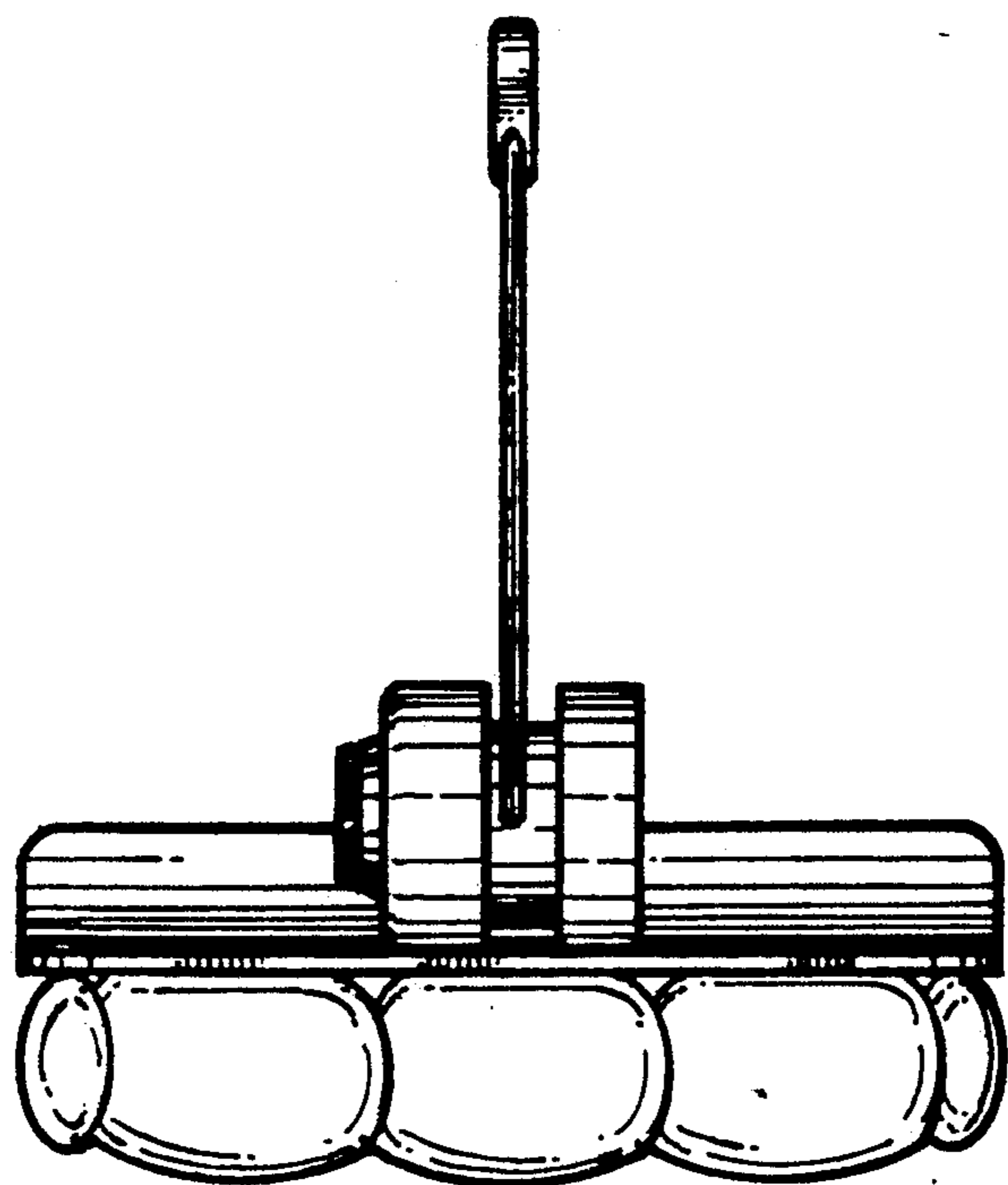

FIG. 3

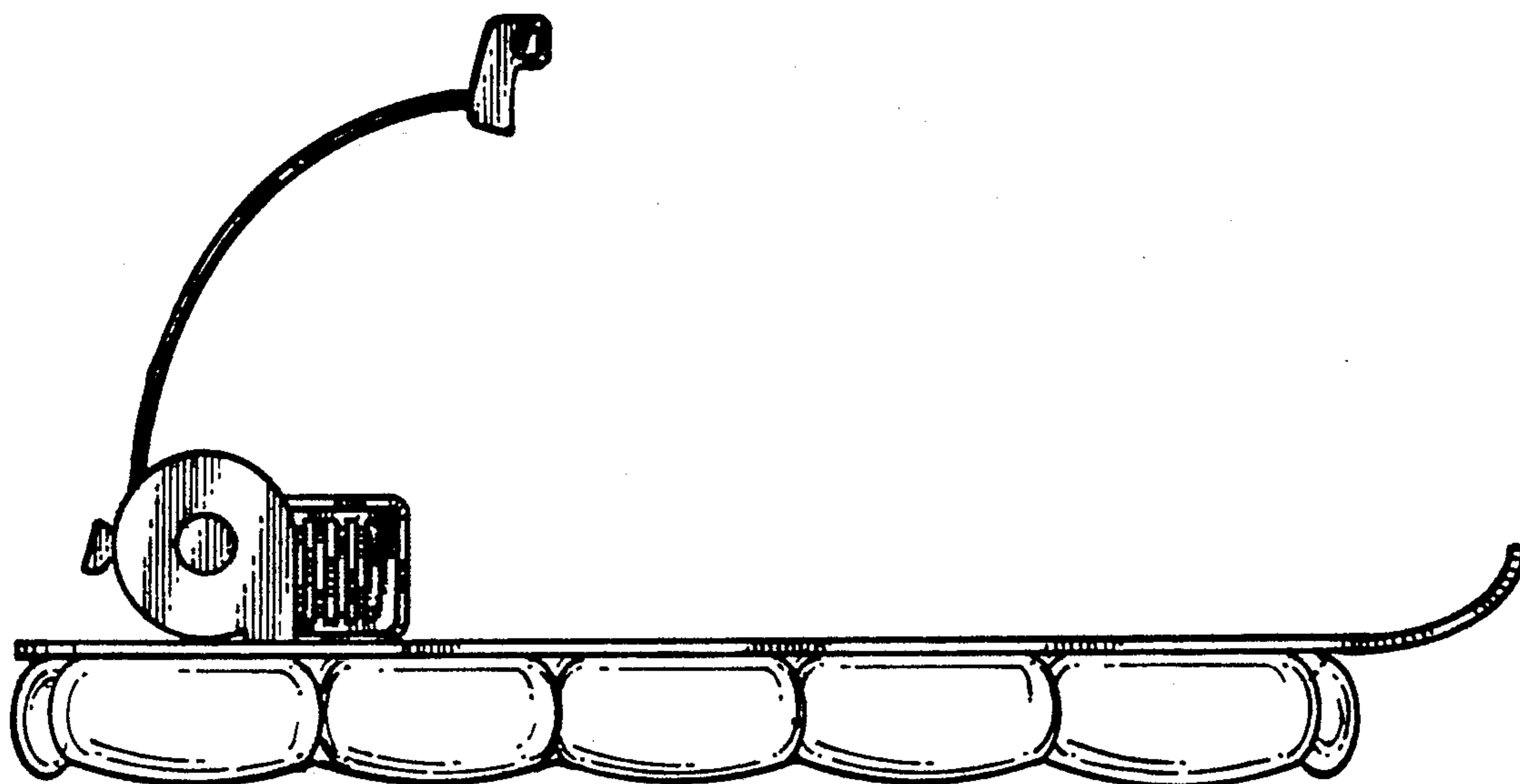

FIG. 4

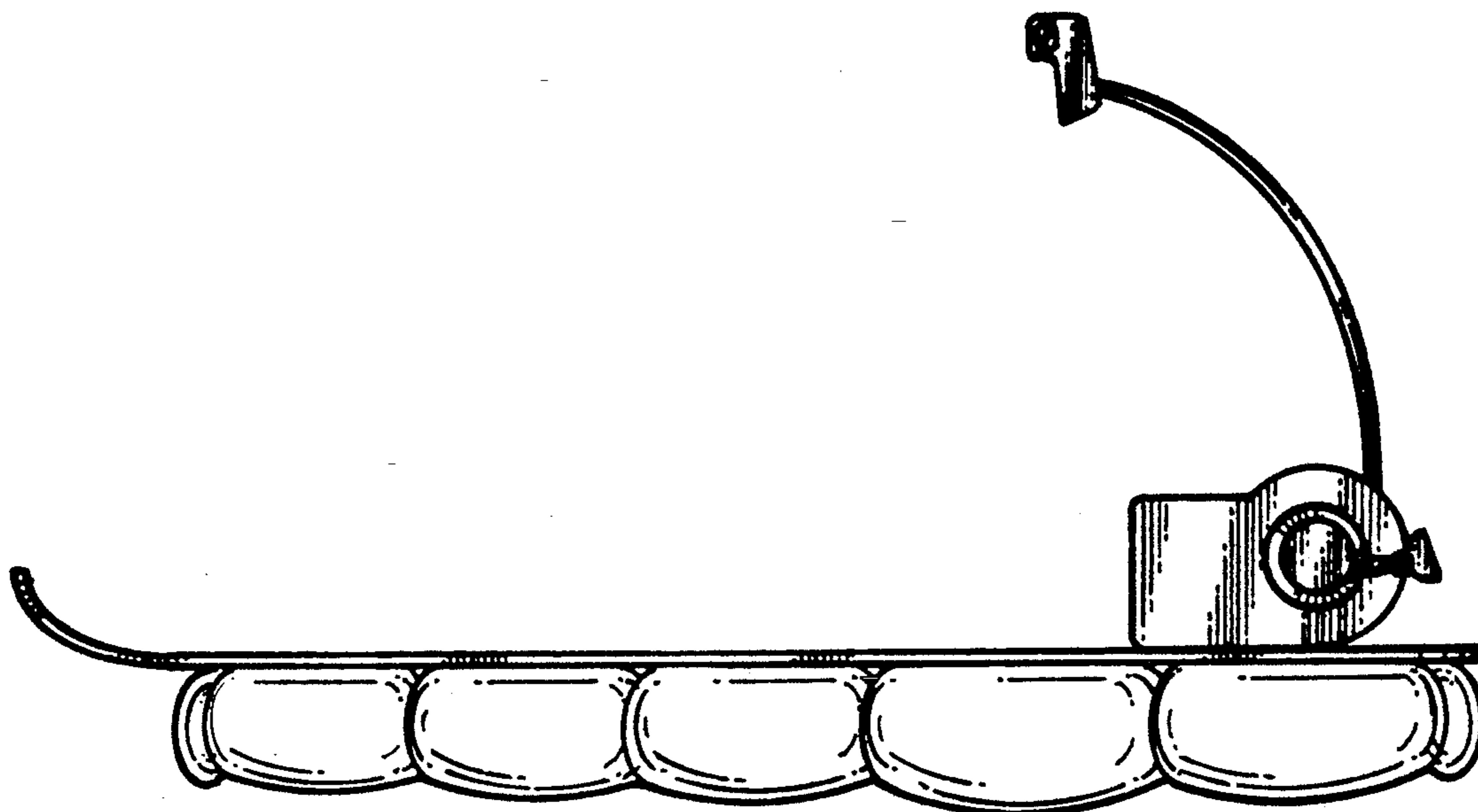

FIG. 5

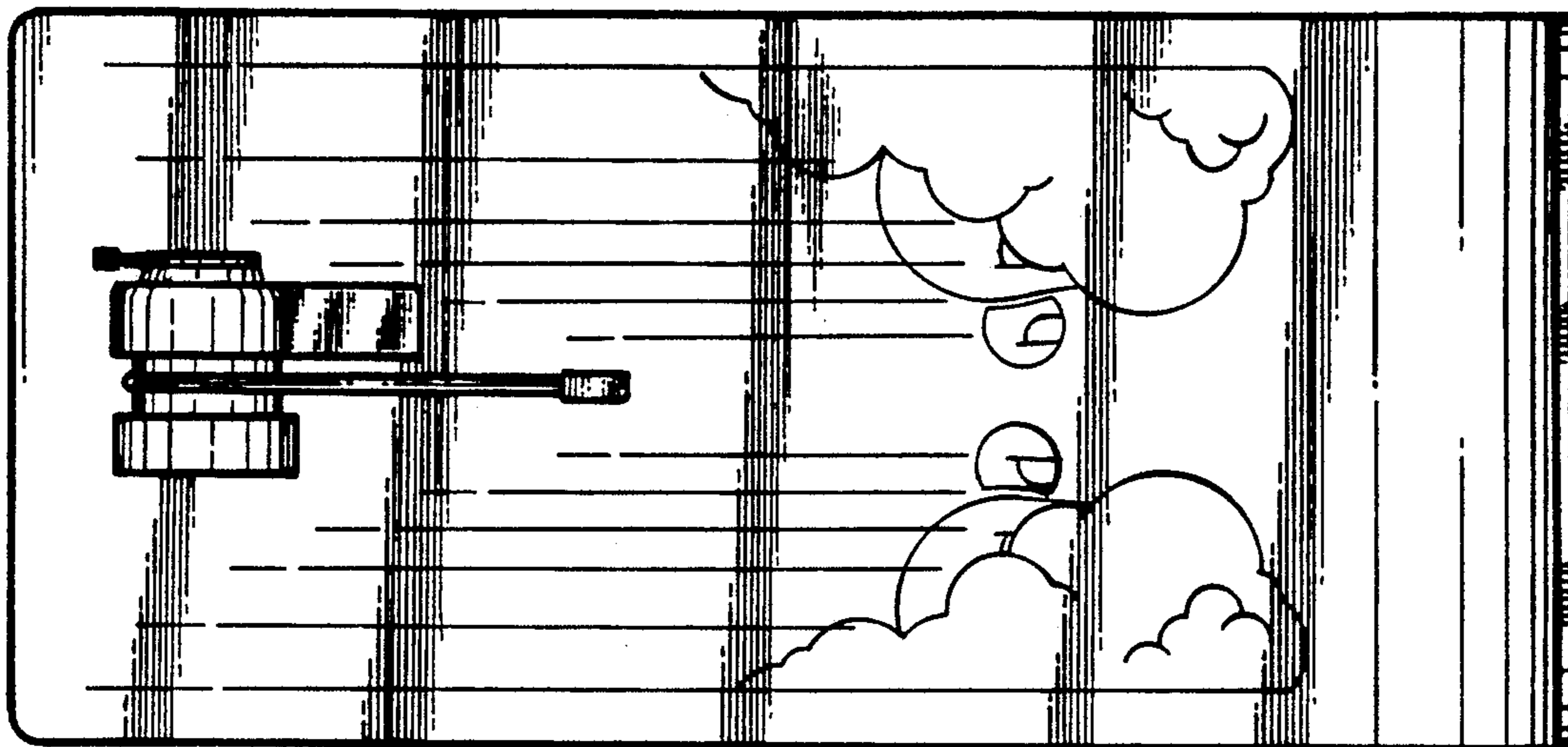

FIG. 6

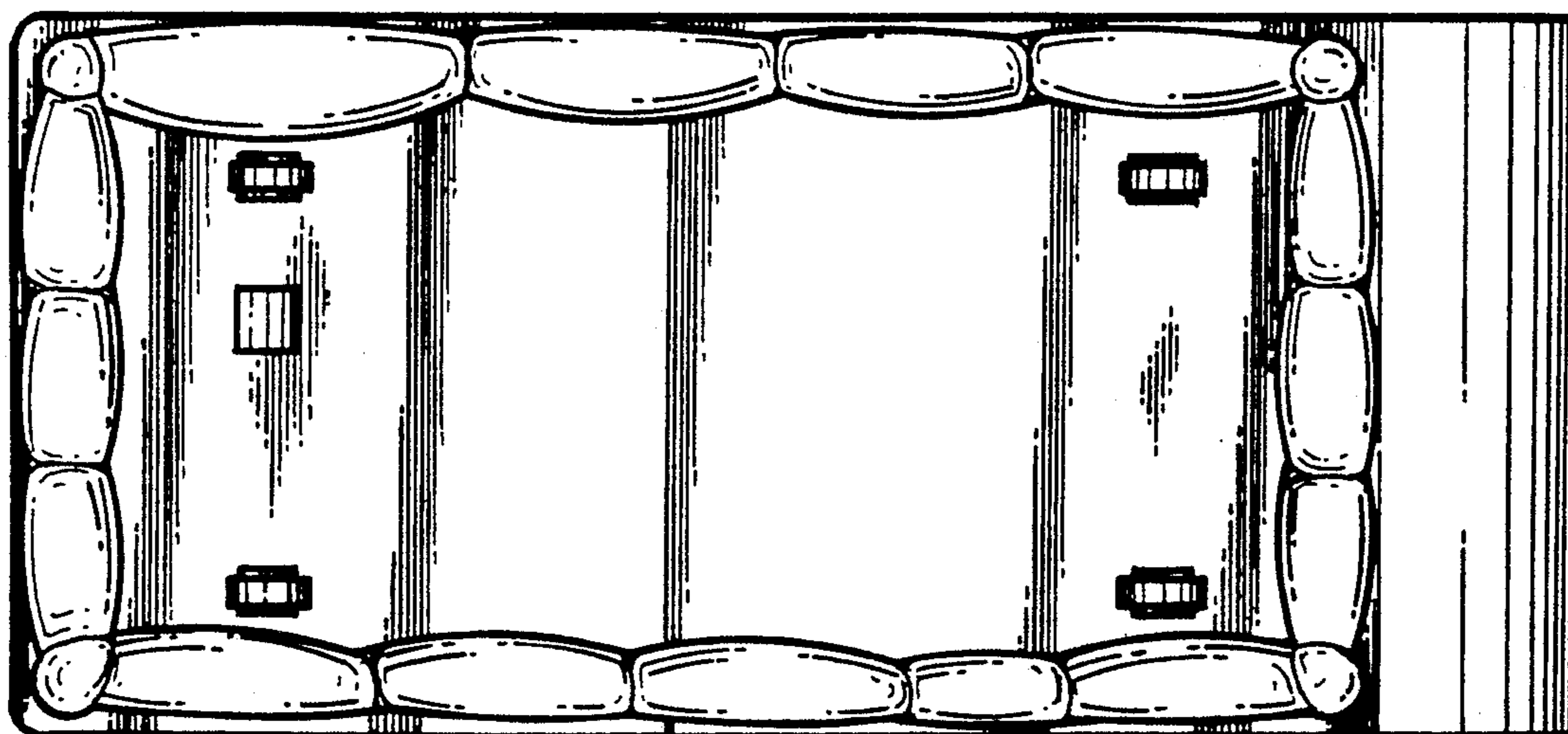

FIG. 7