



US00D331520S

United States Patent [19]

[11] Patent Number: **Des. 331,520**

Ruddy

[45] Date of Patent: **** Dec. 8, 1992**

[54] CAR PILLOW

[76] Inventor: **Mark Ruddy, 2740 Xylon Ave. N.
Apt. 2, New Hope, Minn. 55427**

[**] Term: **14 Years**

[21] Appl. No.: **624,244**

[22] Filed: **Dec. 7, 1990**

[52] U.S. Cl. **D6/601**

[58] Field of Search **D6/595-596,
D6/597, 601, 604; 5/431-432, 434, 436,
440-441, 448, 470-471; 297/391, 397**

4,165,125	8/1979	Owen .	
4,440,443	4/1984	Nordskog	297/397
4,738,488	4/1988	Camelio	297/391
4,773,707	9/1988	Vadala .	
4,838,611	6/1989	Talaugon	297/391
4,848,836	7/1989	Massui .	

Primary Examiner—Brian N. Vinson
Attorney, Agent, or Firm—Terry M. Gernstein

[57] CLAIM

The ornamental design for a car pillow, as shown and described.

DESCRIPTION

FIG. 1 is a top, front, and left side perspective view of a car pillow showing my new design;
 FIG. 2 is a front elevational view thereof;
 FIG. 3 is a rear elevational view thereof;
 FIG. 4 is a right side elevational view thereof, the left side being a mirror image of that shown;
 FIG. 5 is a top plan view thereof; and,
 FIG. 6 is a bottom plan view thereof.

[56] References Cited

U.S. PATENT DOCUMENTS

D. 159,483	8/1950	Glassman	D6/604
D. 238,537	1/1976	Longacre	D6/596
D. 264,164	5/1982	Salibello et al.	D6/596
D. 284,151	6/1986	Johnson	D6/601 X
D. 308,786	6/1990	Draskovic	D6/601
D. 316,792	5/1991	Schmitz	D6/601

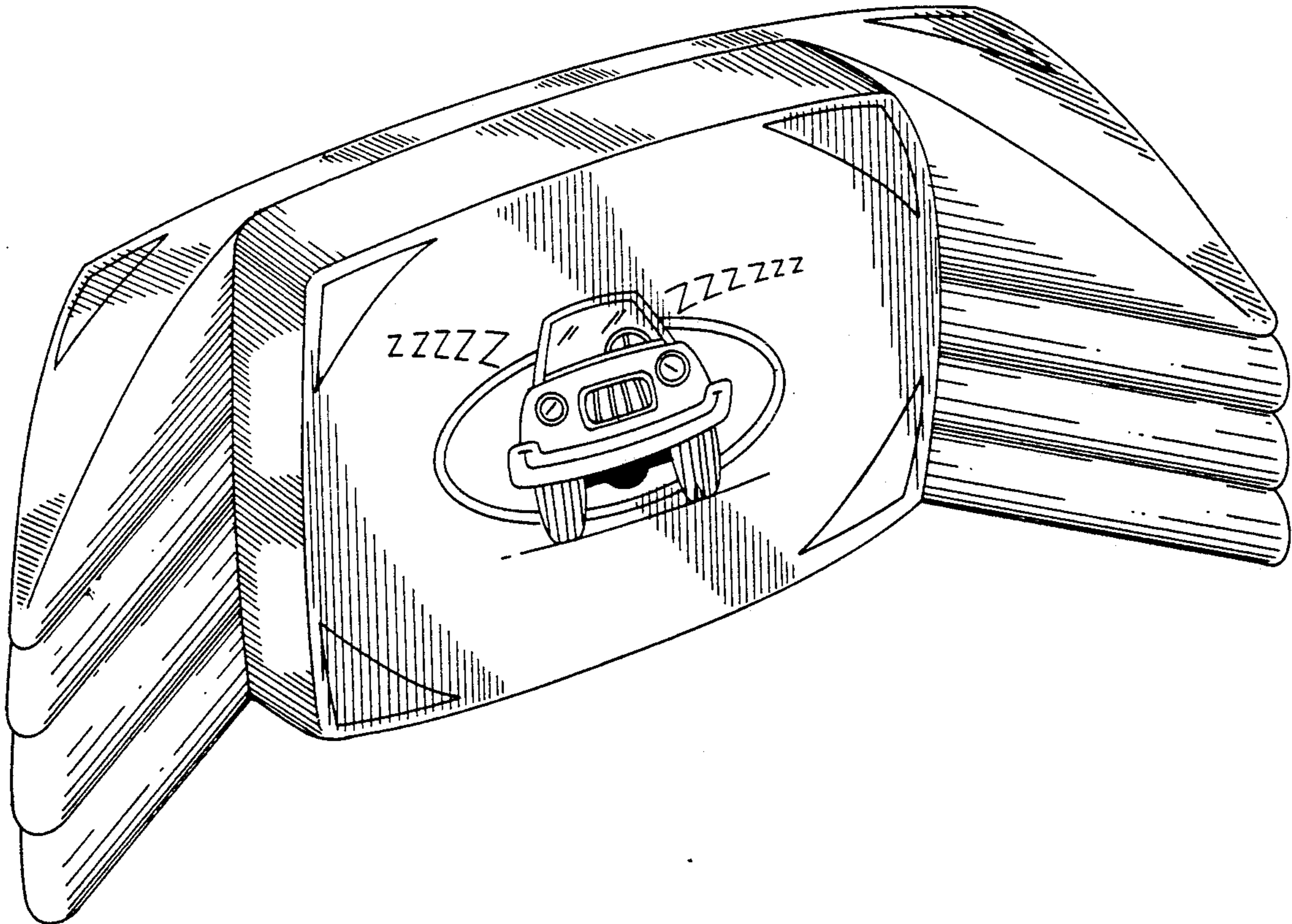

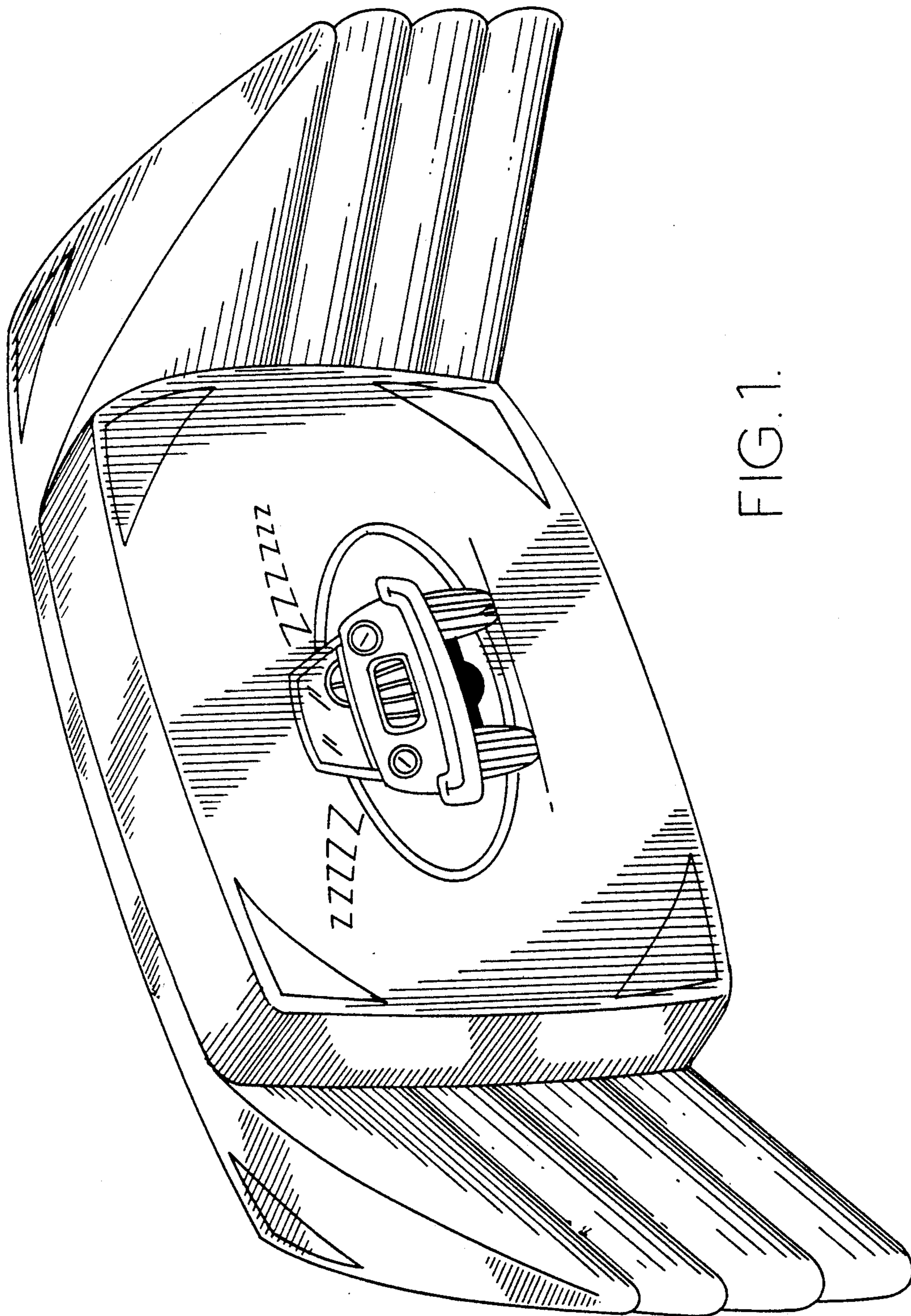

FIG. 1.

FIG. 4.

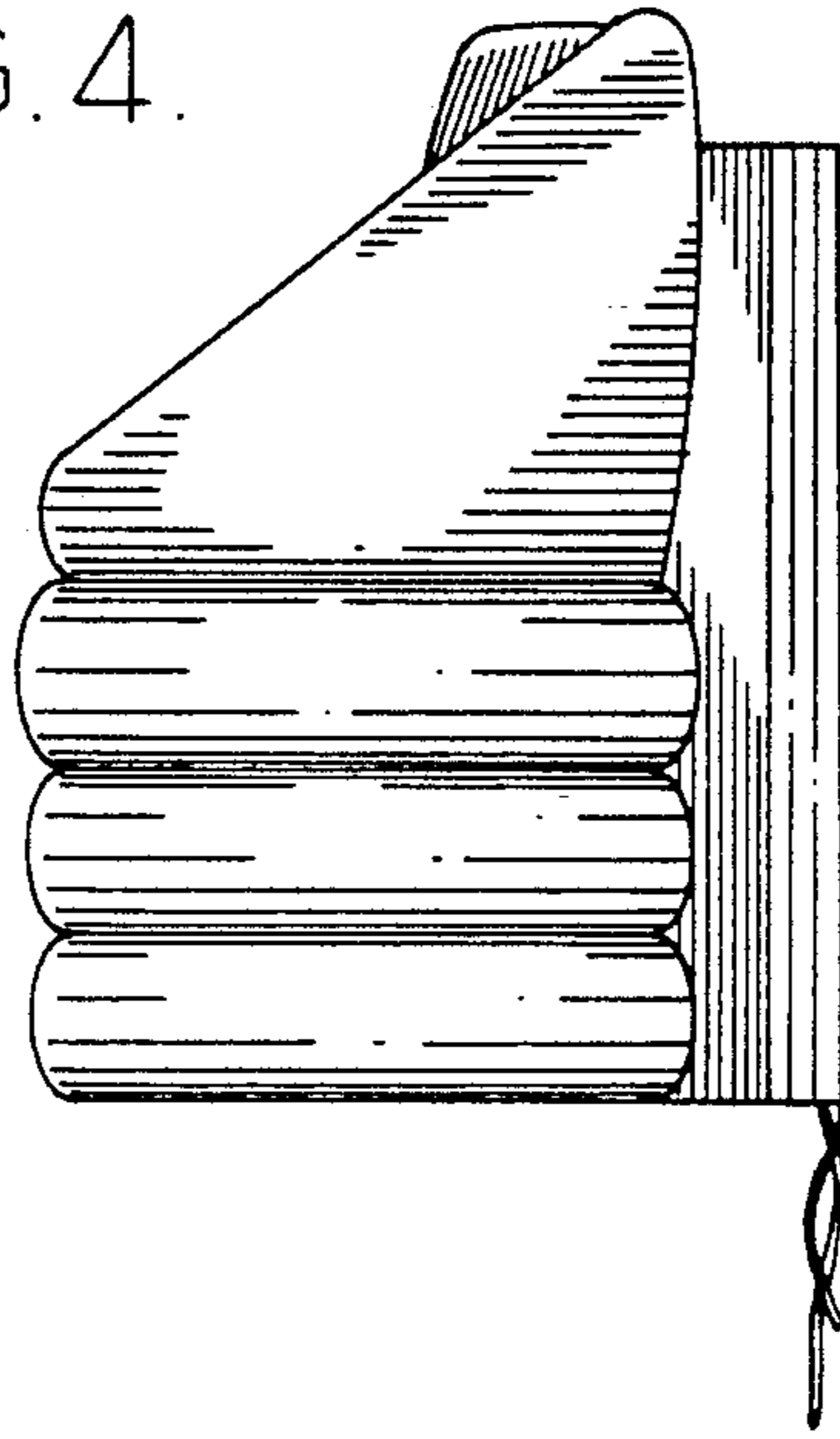

FIG. 2.

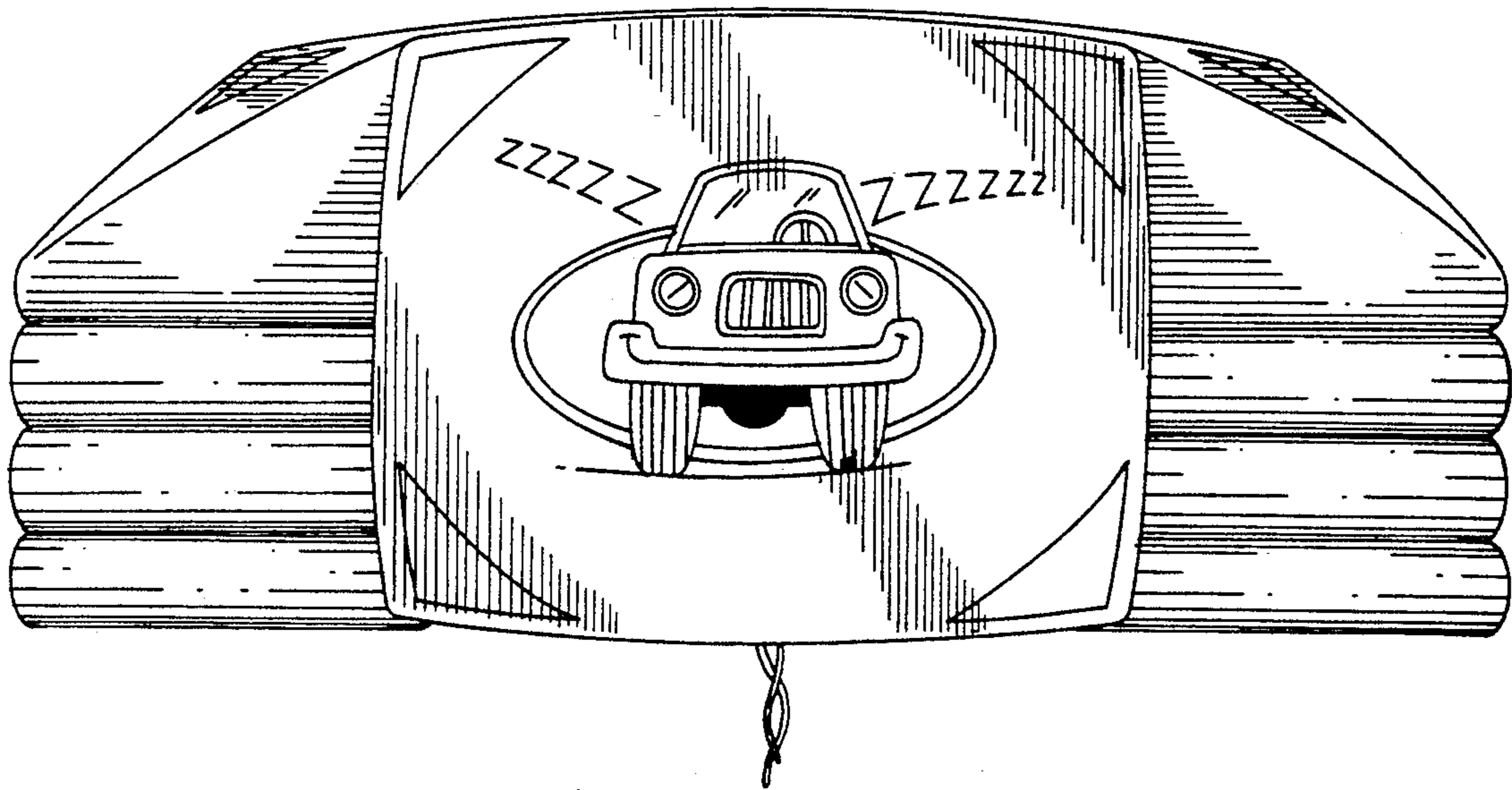

FIG. 5.

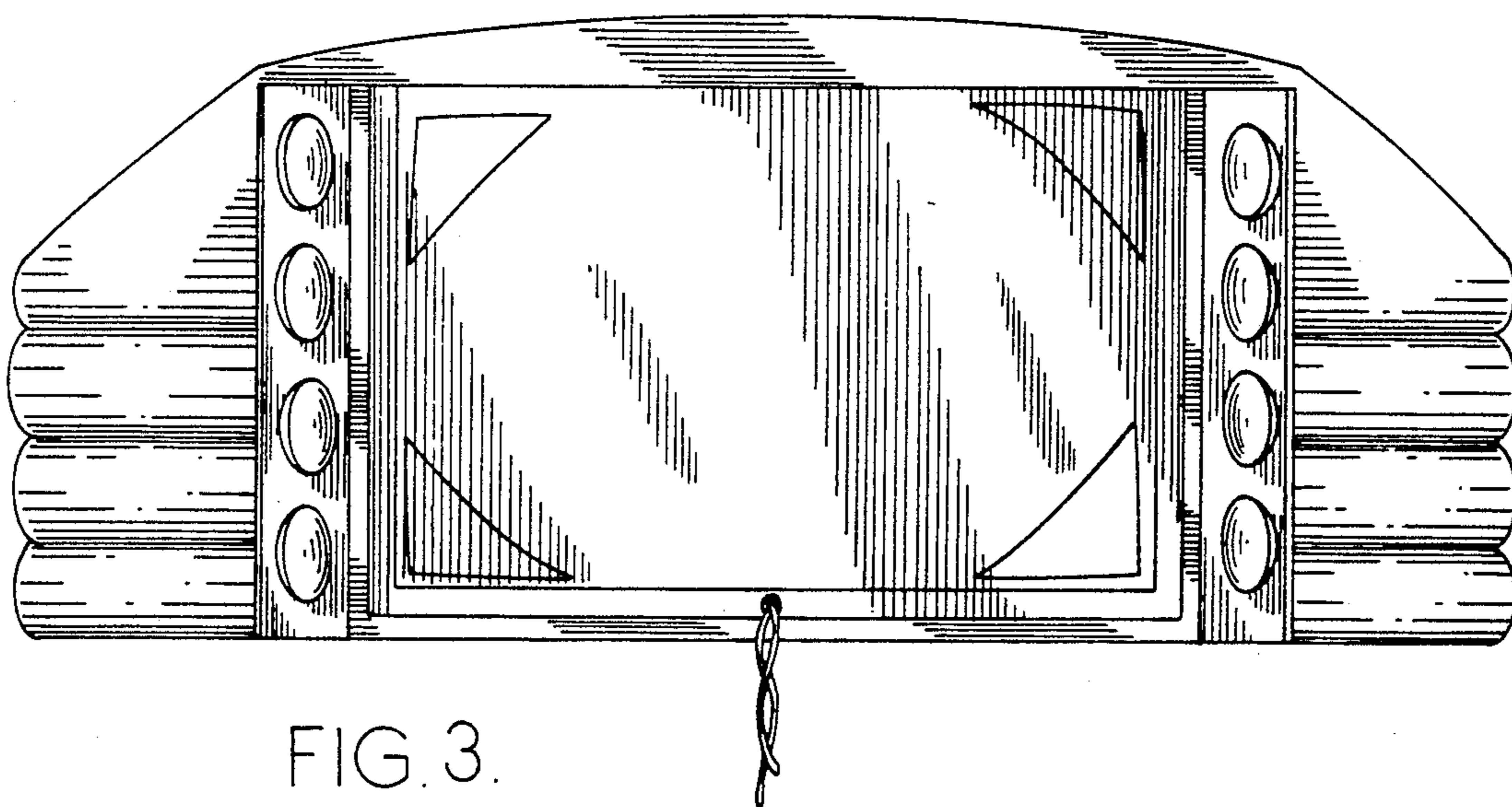
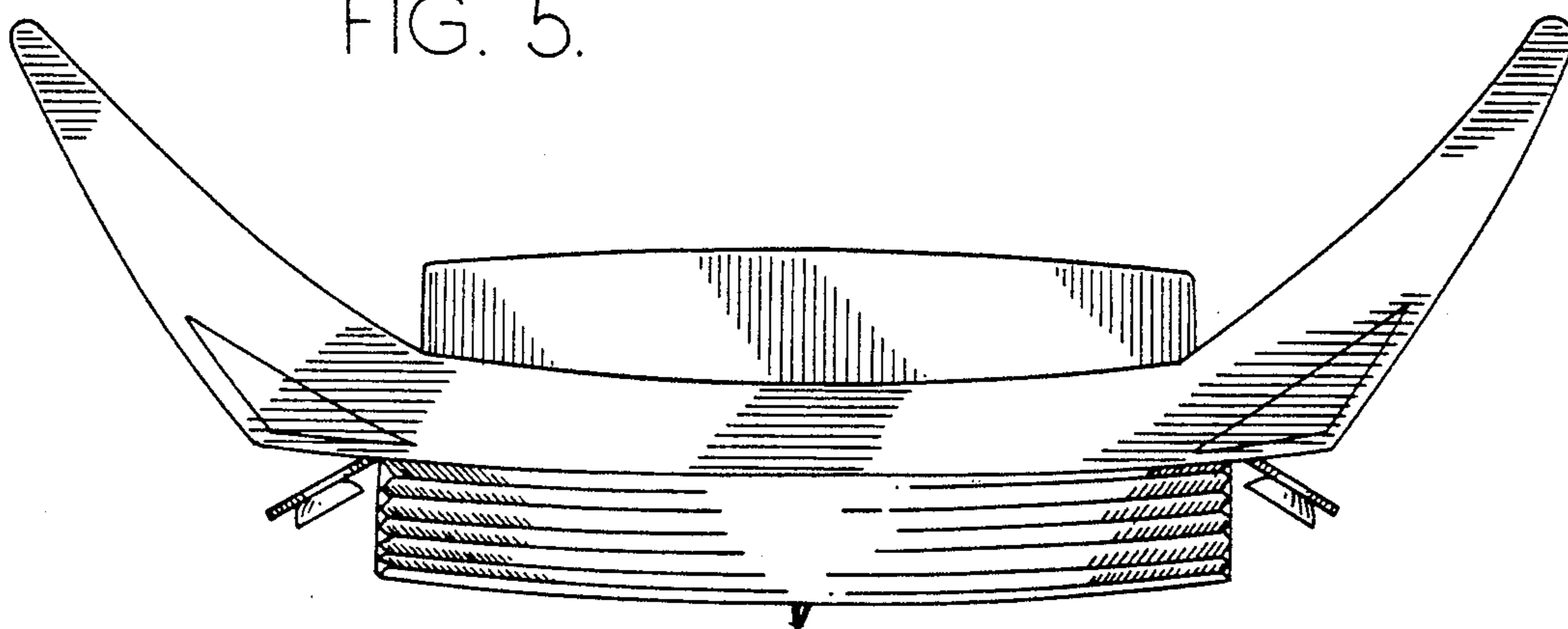

FIG. 3.

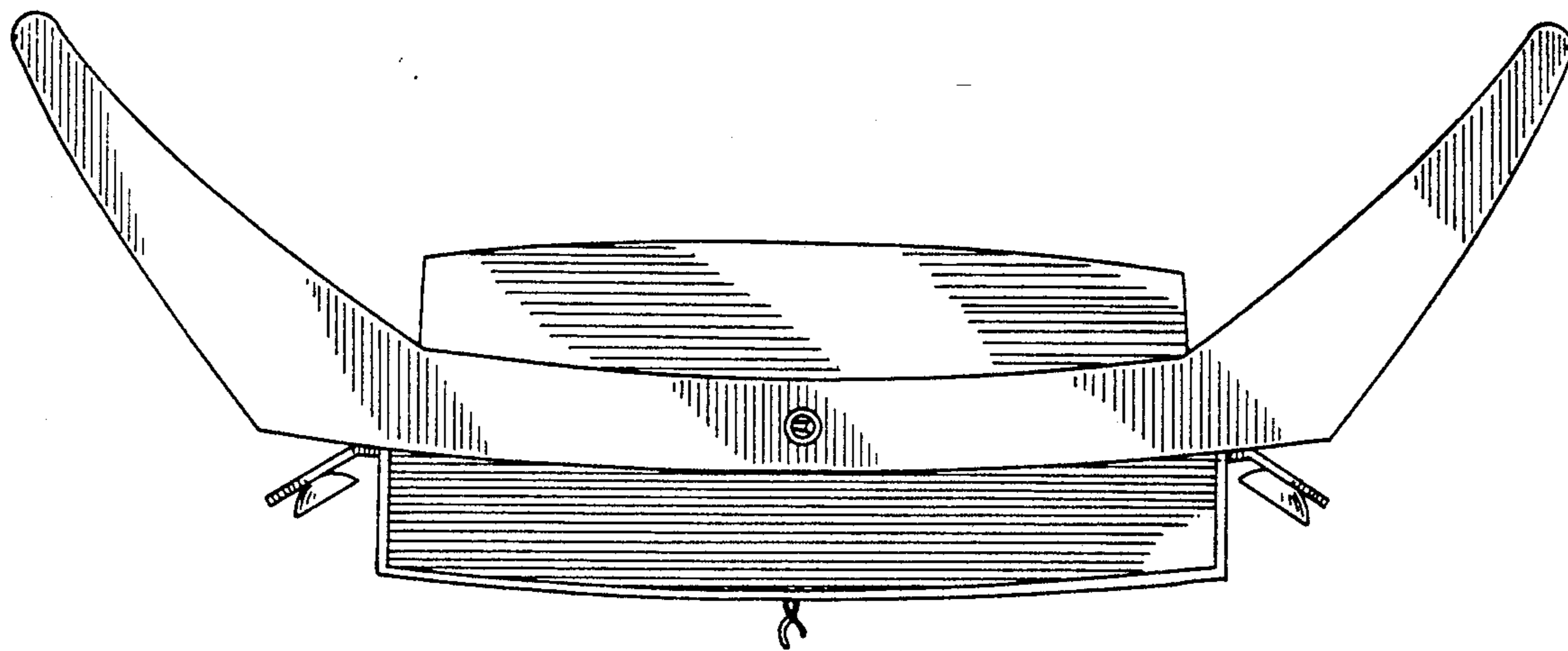

FIG. 6.