



US00D331219S

United States Patent [19]

[11] Patent Number: **Des. 331,219**

Barbour et al.

[45] Date of Patent: **** Nov. 24, 1992**

[54] TELESCOPING BOAT LADDERS

[57] CLAIM

[75] Inventors: **Robert G. Barbour; Glenn A. Smith,**
both of Los Angeles, Calif.

The ornamental design for a telescoping boat ladder, as shown and described.

[73] Assignee: **Windline Marine, Los Angeles, Calif.**

DESCRIPTION

[**] Term: **14 Years**

FIG. 1 is a top and front perspective view of a telescoping boat ladder showing my new design;
FIG. 2 is a side elevational view thereof, the opposite side elevational view being a mirror image of that shown;

[21] Appl. No.: **691,120**

FIG. 3 is a top plan view thereof;

[22] Filed: **Apr. 25, 1991**

FIG. 4 is a front elevational view thereof;

[52] U.S. Cl. **D12/317; D29/1**

FIG. 5 is a rear elevational view thereof;

[58] Field of Search **D12/317, 318; 114/362, 114/363; 182/84, 86, 91, 106, 93; D29/1**

FIG. 6 is a bottom plan view thereof;

FIG. 7 is a top perspective view thereof in a collapsed condition;

[56] **References Cited**

U.S. PATENT DOCUMENTS

3,804,200	4/1974	Sandberg	114/362
4,637,492	1/1987	Herr	182/93
4,823,910	4/1989	Day	182/84

FIG. 8 is a top and front perspective view of a second embodiment of the telescoping boat ladder;

FIG. 9 is a side elevational view of FIG. 8;

FIG. 10 is a top plan view of FIG. 8;

FIG. 11 is a front elevational view of FIG. 8;

FIG. 12 is a rear elevational view of FIG. 8;

FIG. 13 is a bottom plan view of FIG. 8; and,

FIG. 14 is a bottom perspective view of FIG. 8 in a collapsed condition.

Primary Examiner—**Kay H. Chin**

Attorney, Agent, or Firm—**Blakely, Sokoloff, Taylor & Zafman**

The broken lines shown in FIGS. 1, 2, 3, 4, 5, 7, 8, 9, 10, 11, 12 and 14 are for illustrative purposes only.

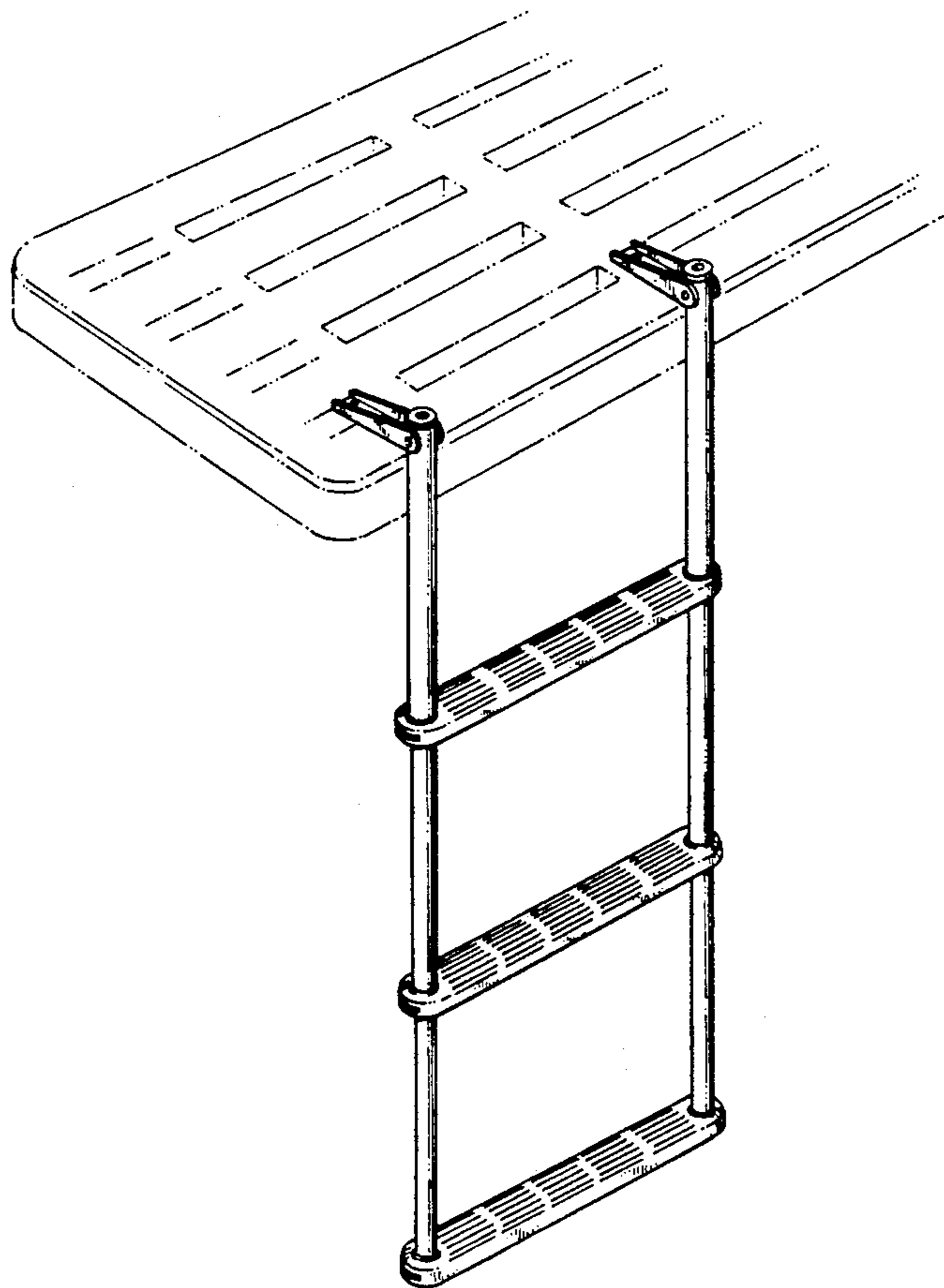

FIG. 1

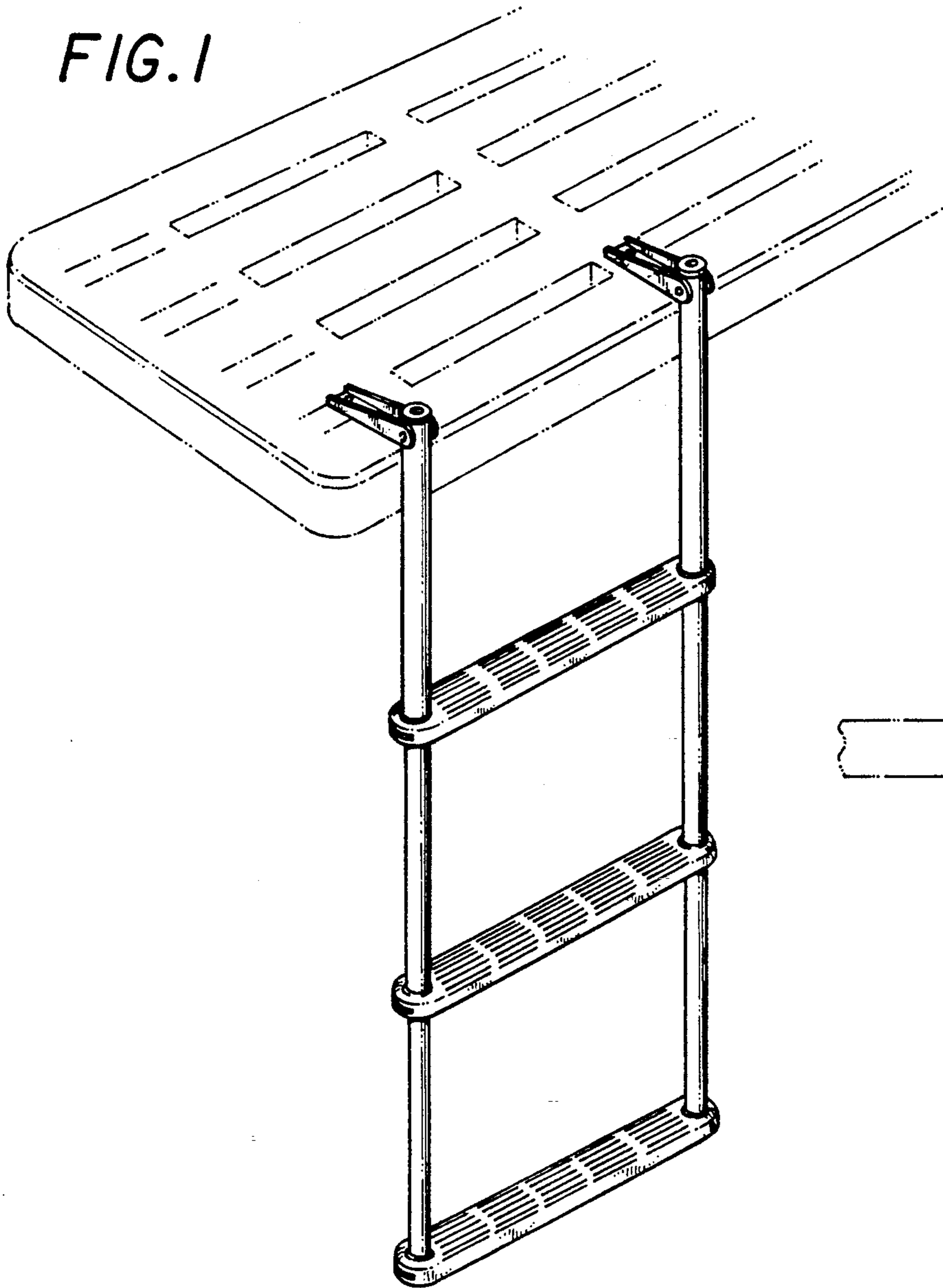

FIG. 2

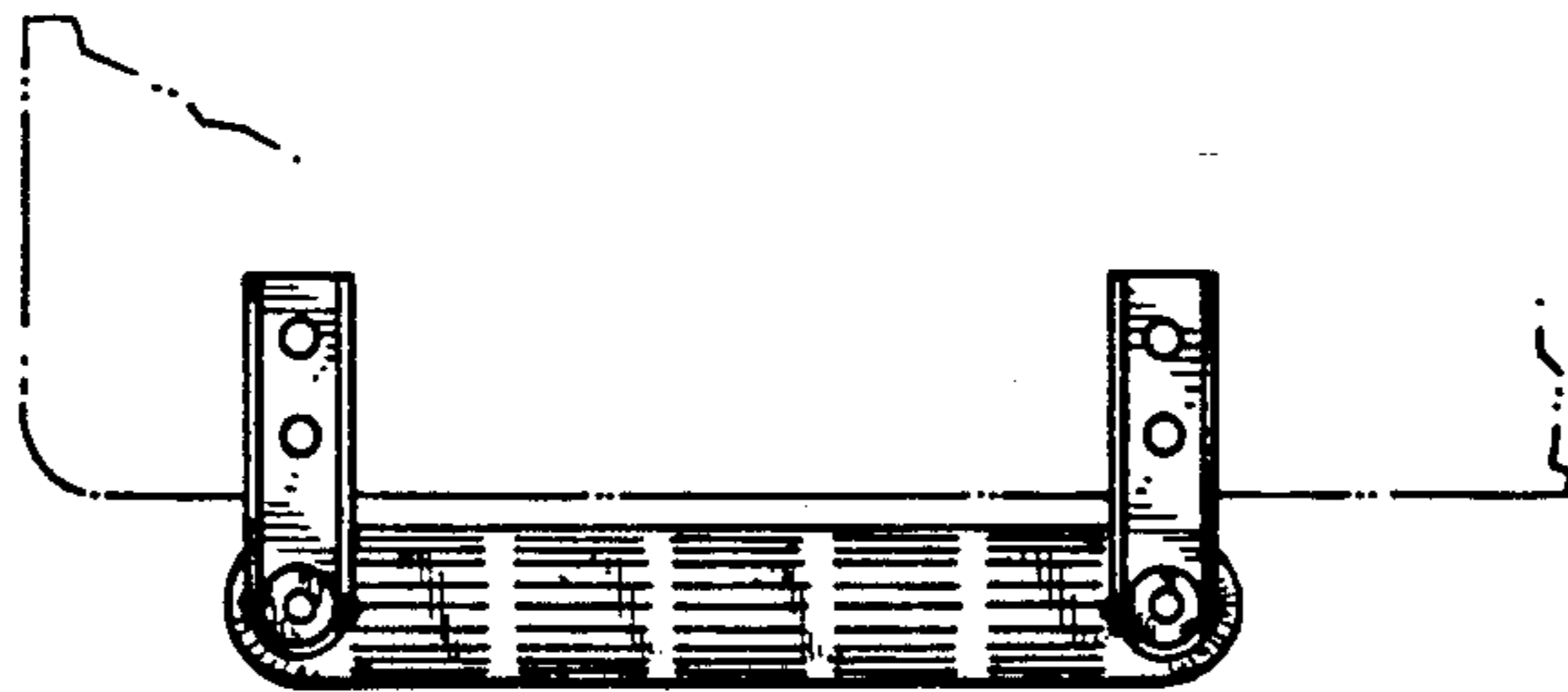
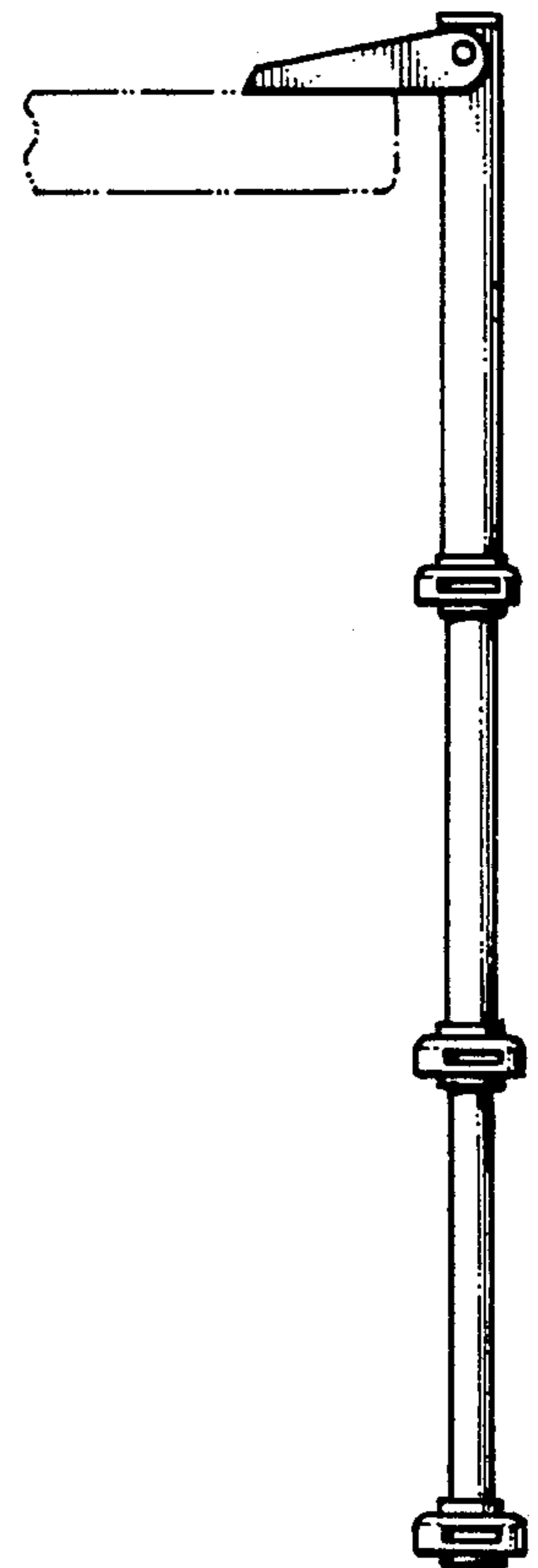

FIG. 3

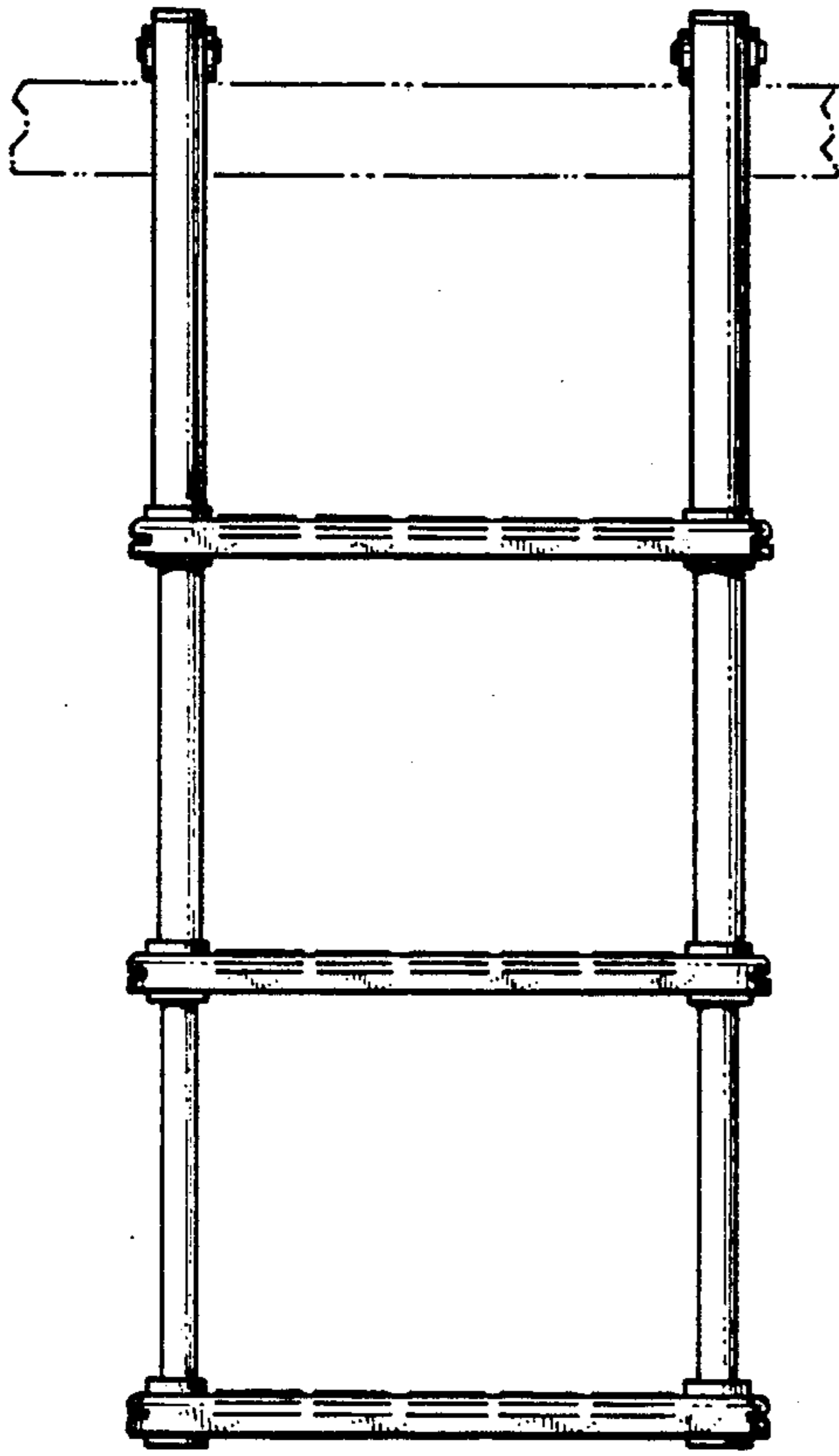

FIG. 4

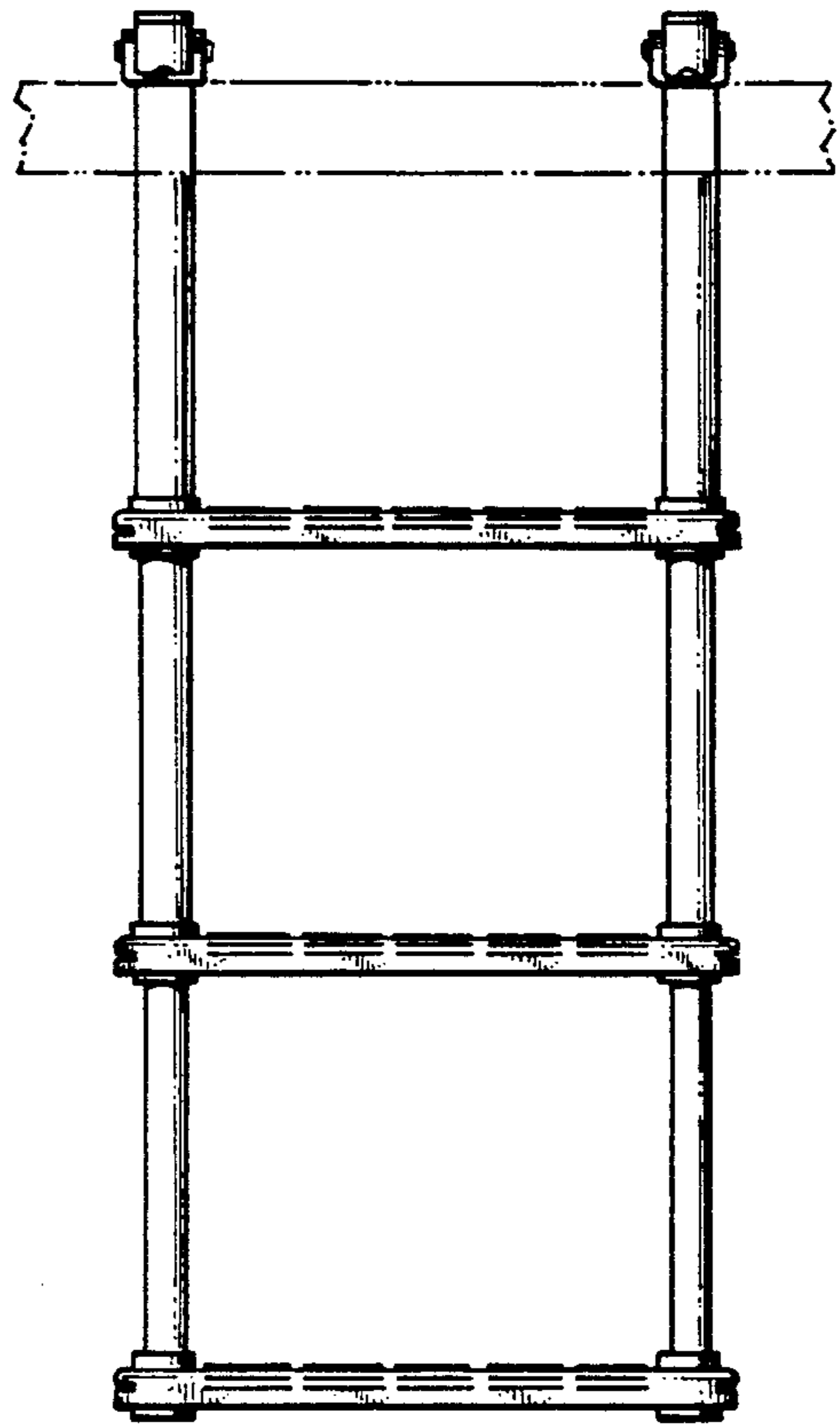

FIG. 5

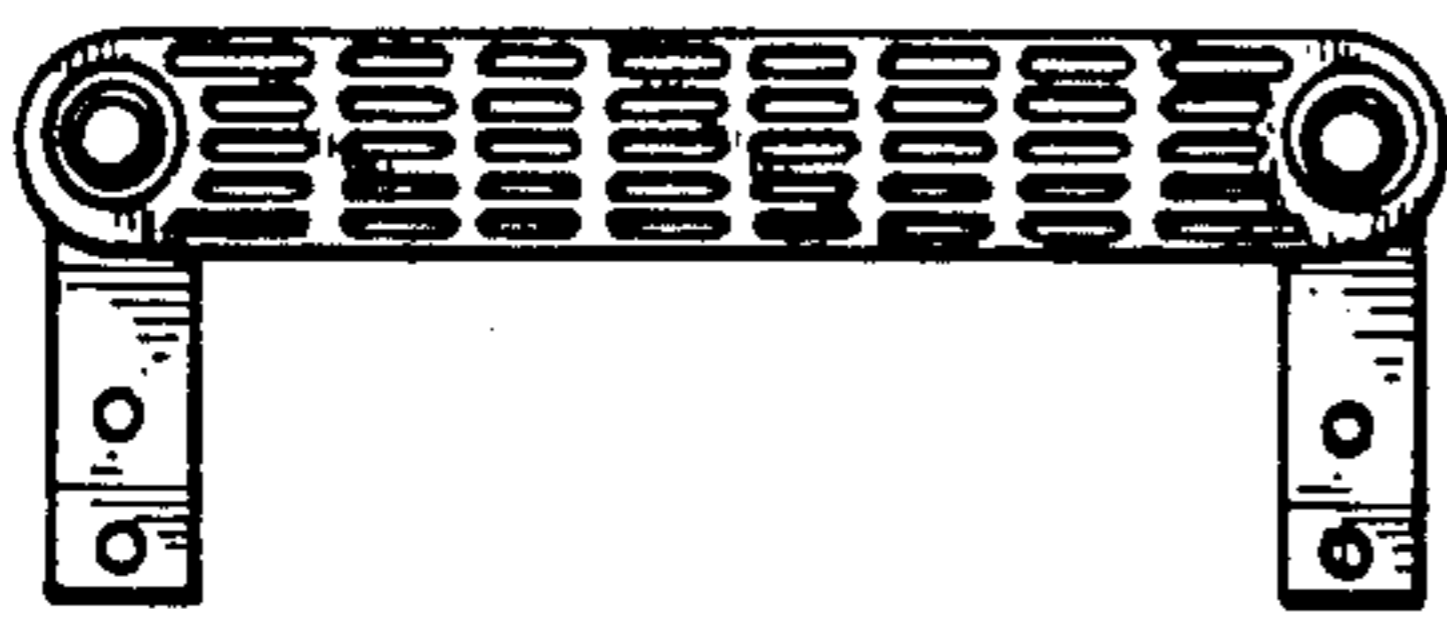

FIG. 6

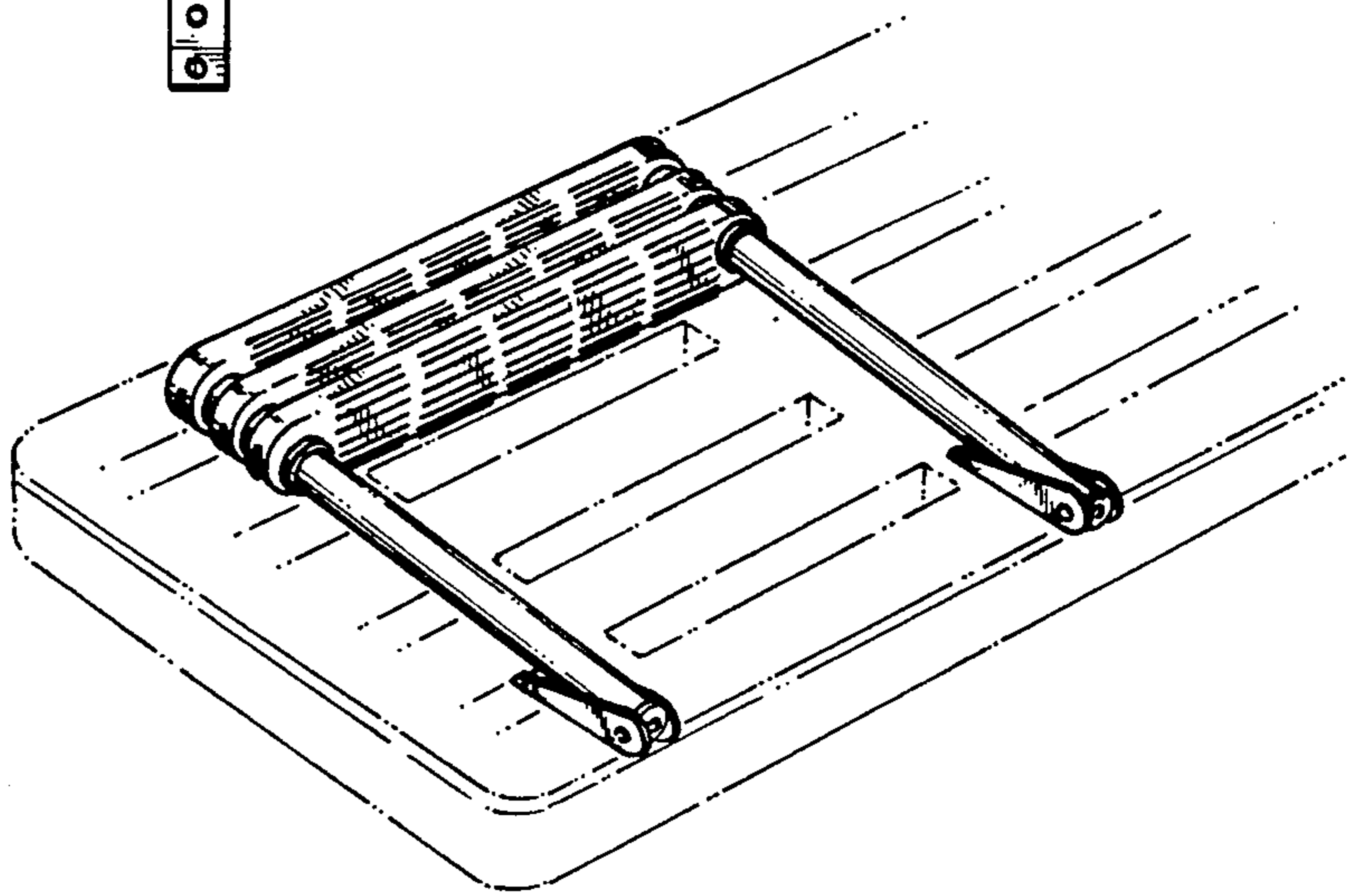

FIG. 7

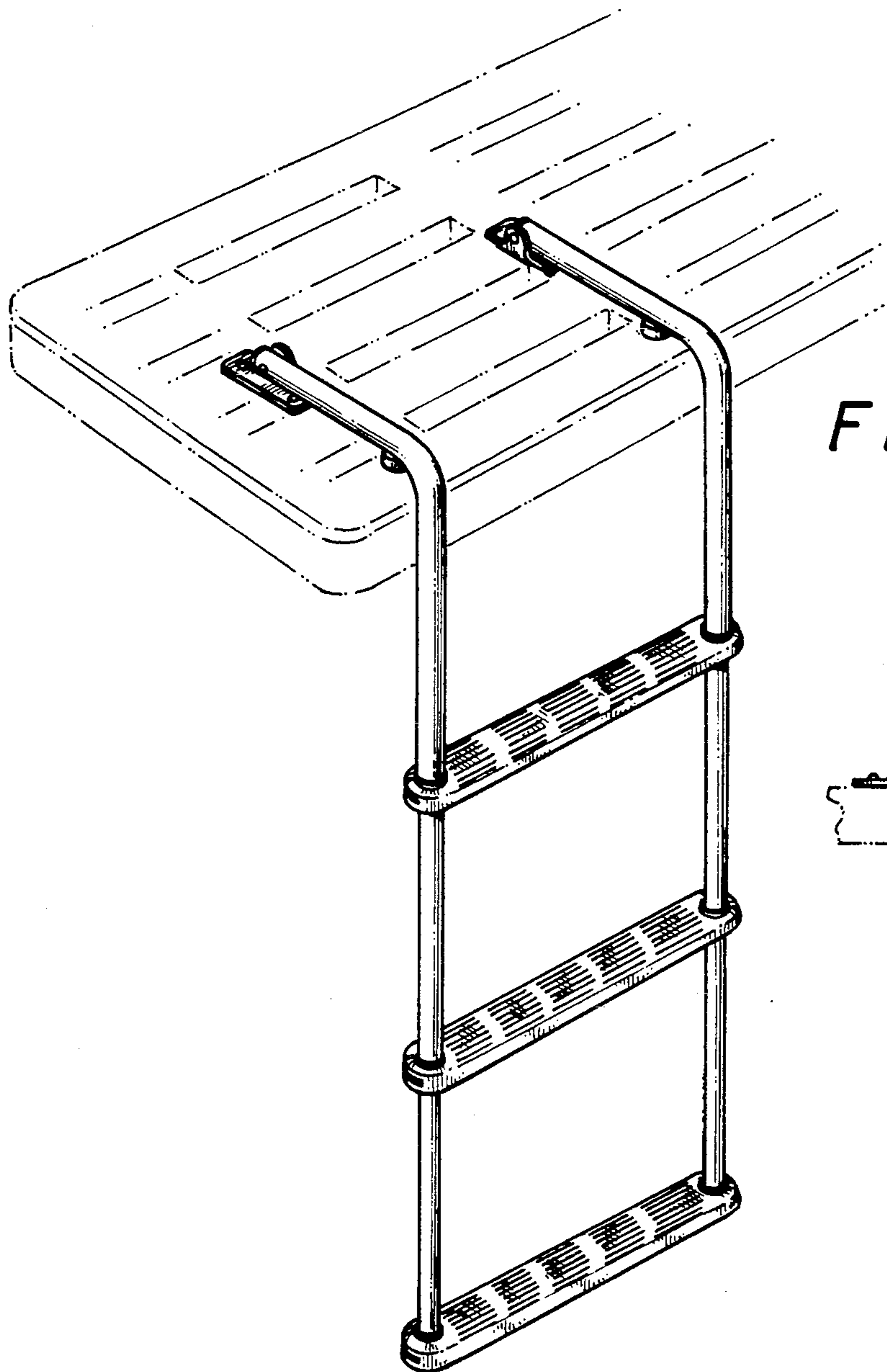

FIG. 8

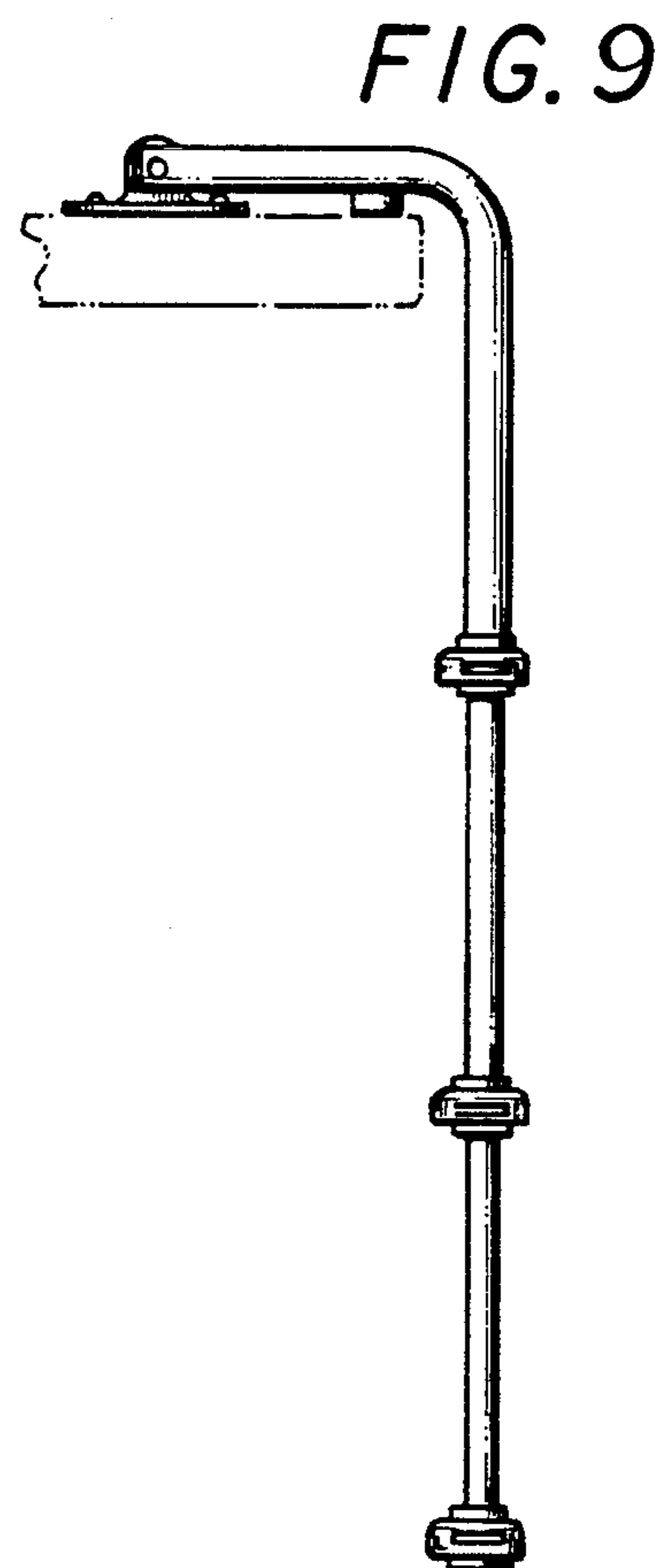

FIG. 9

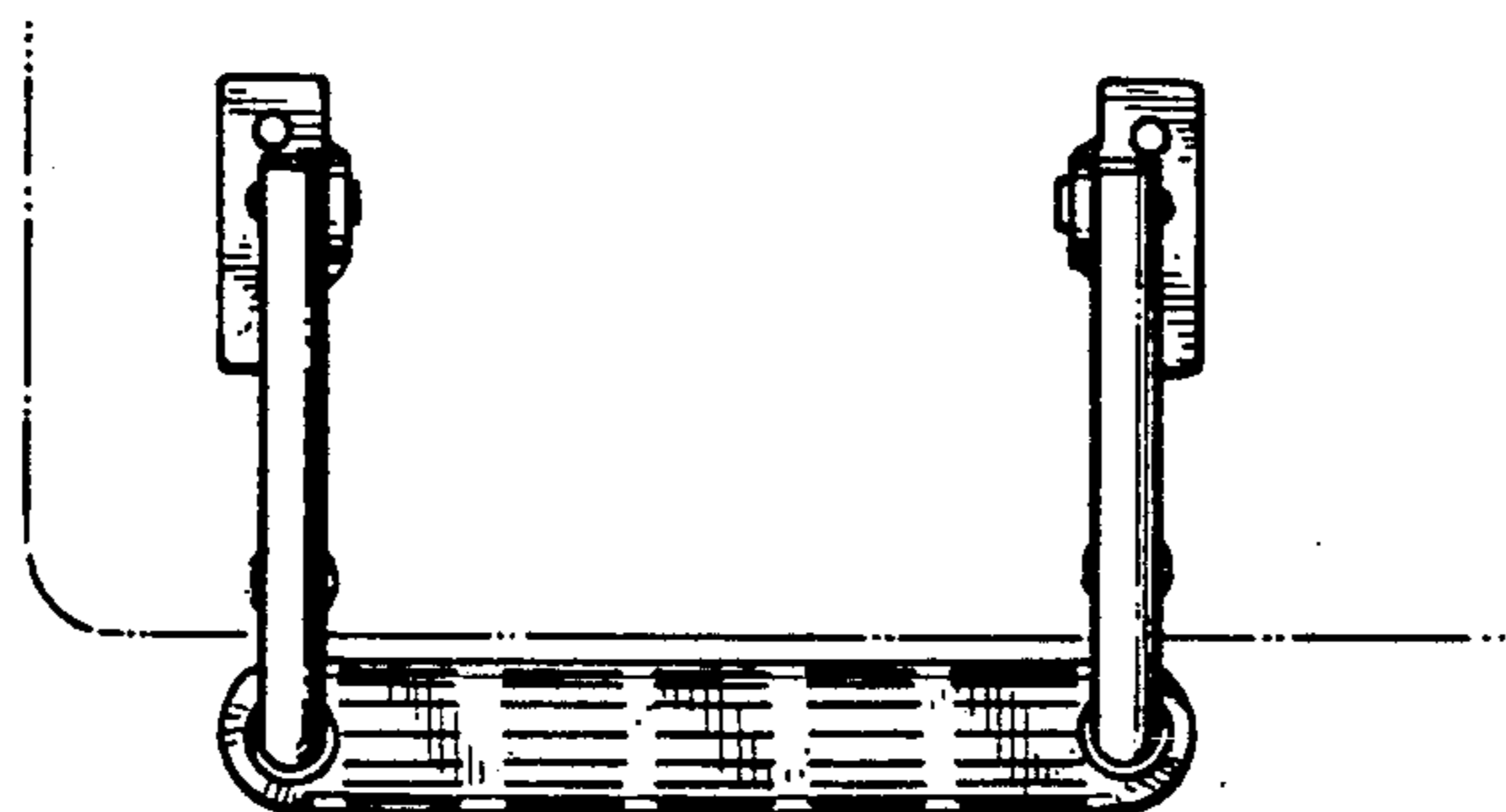

FIG. 10

FIG. 11

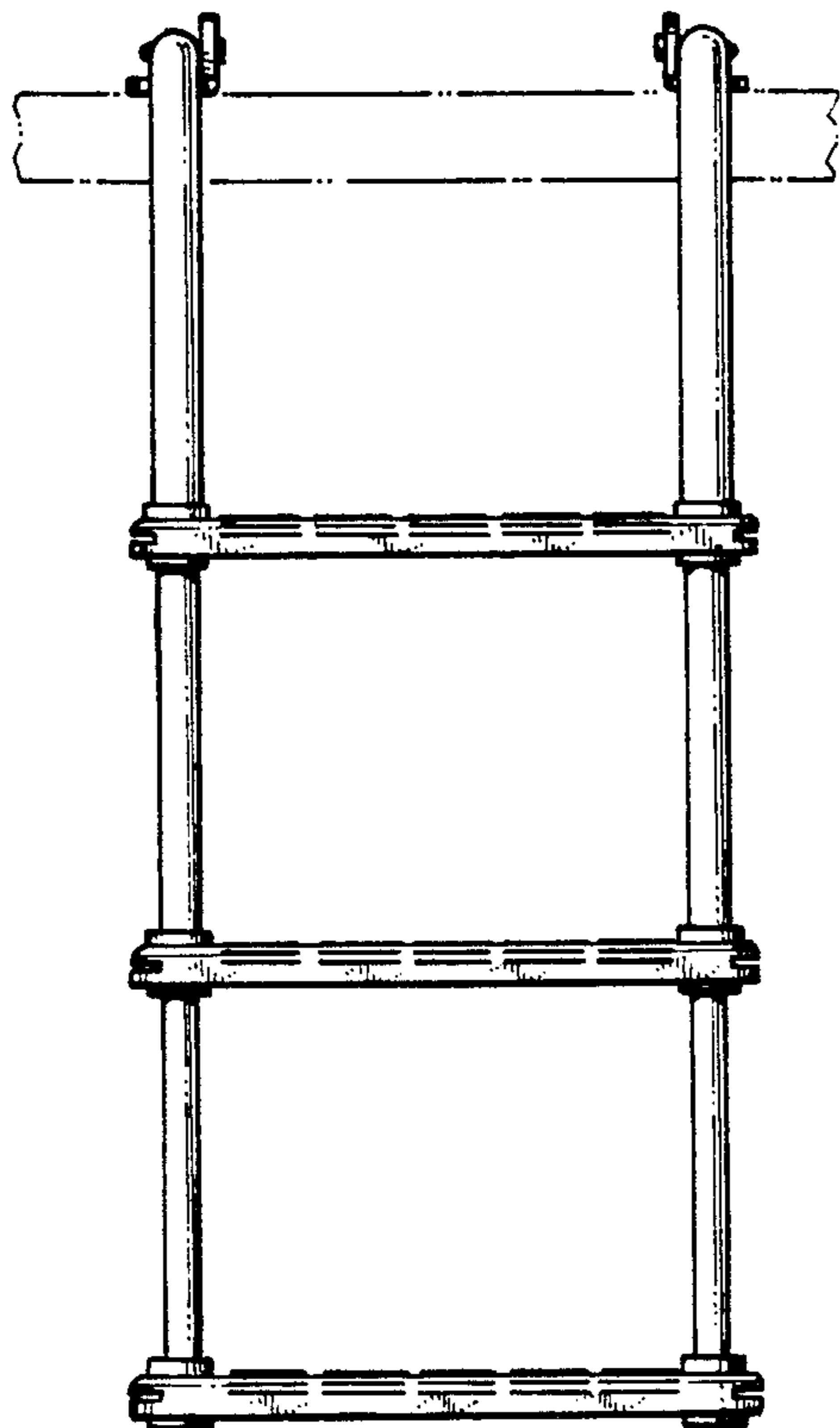

FIG. 12

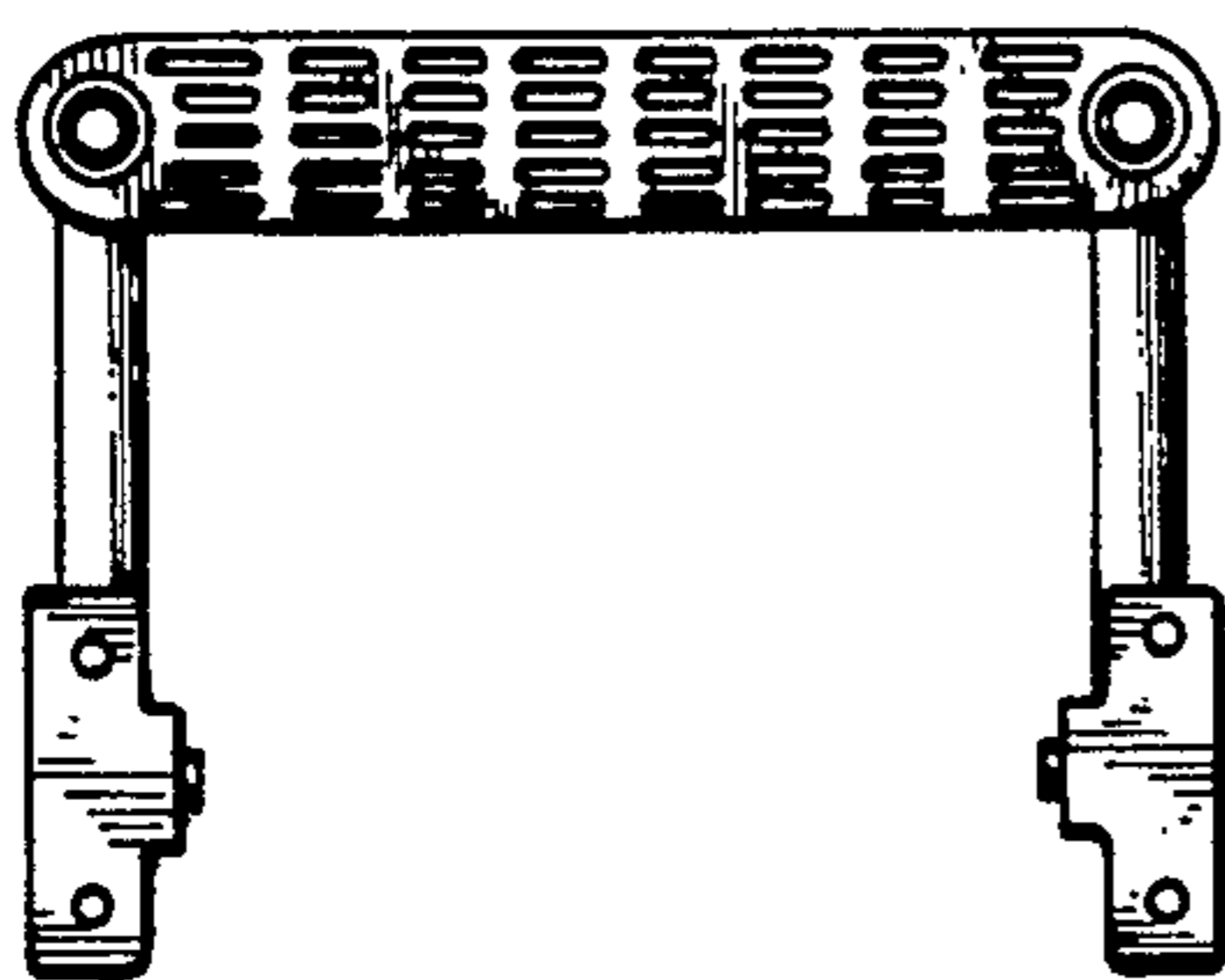
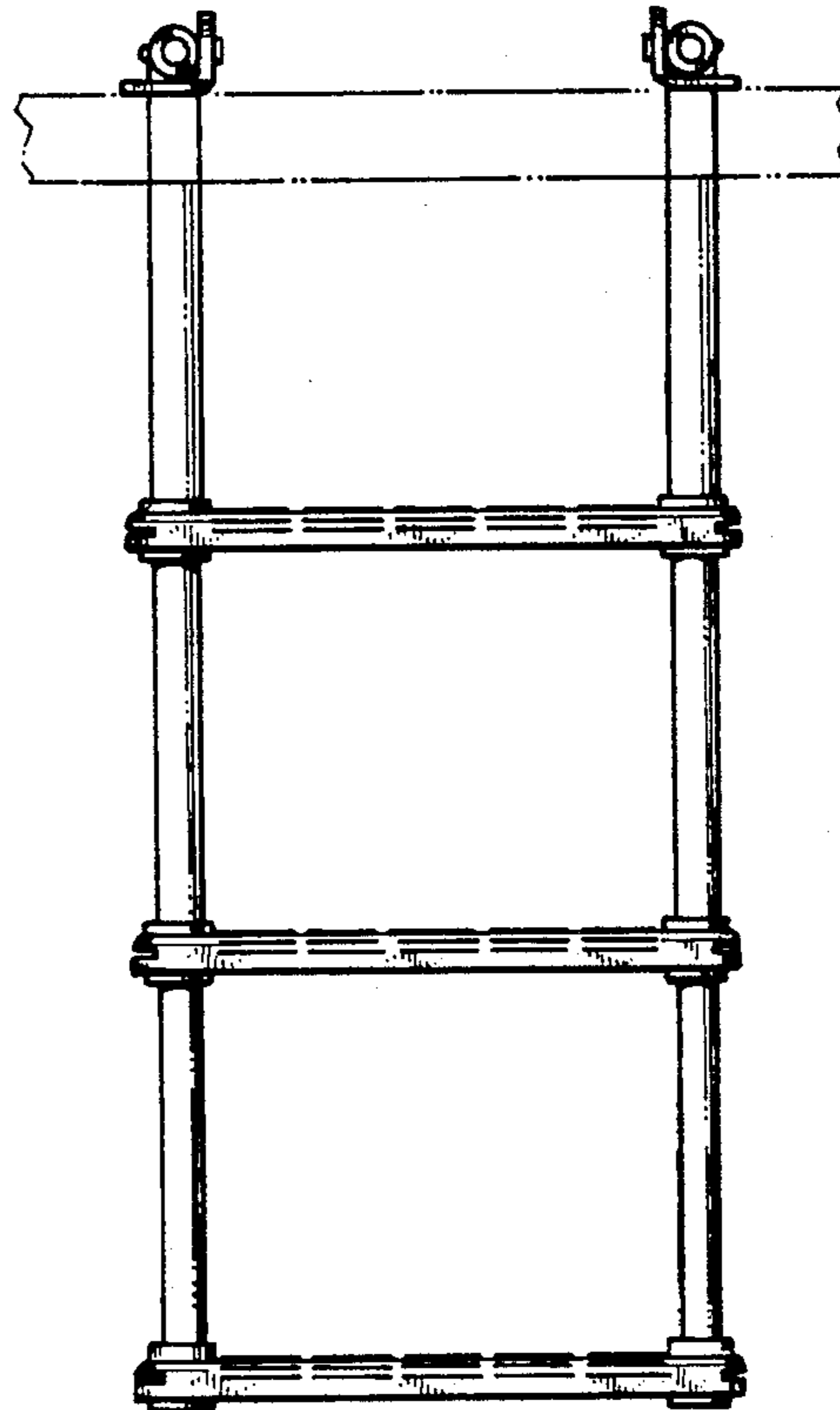

FIG. 13

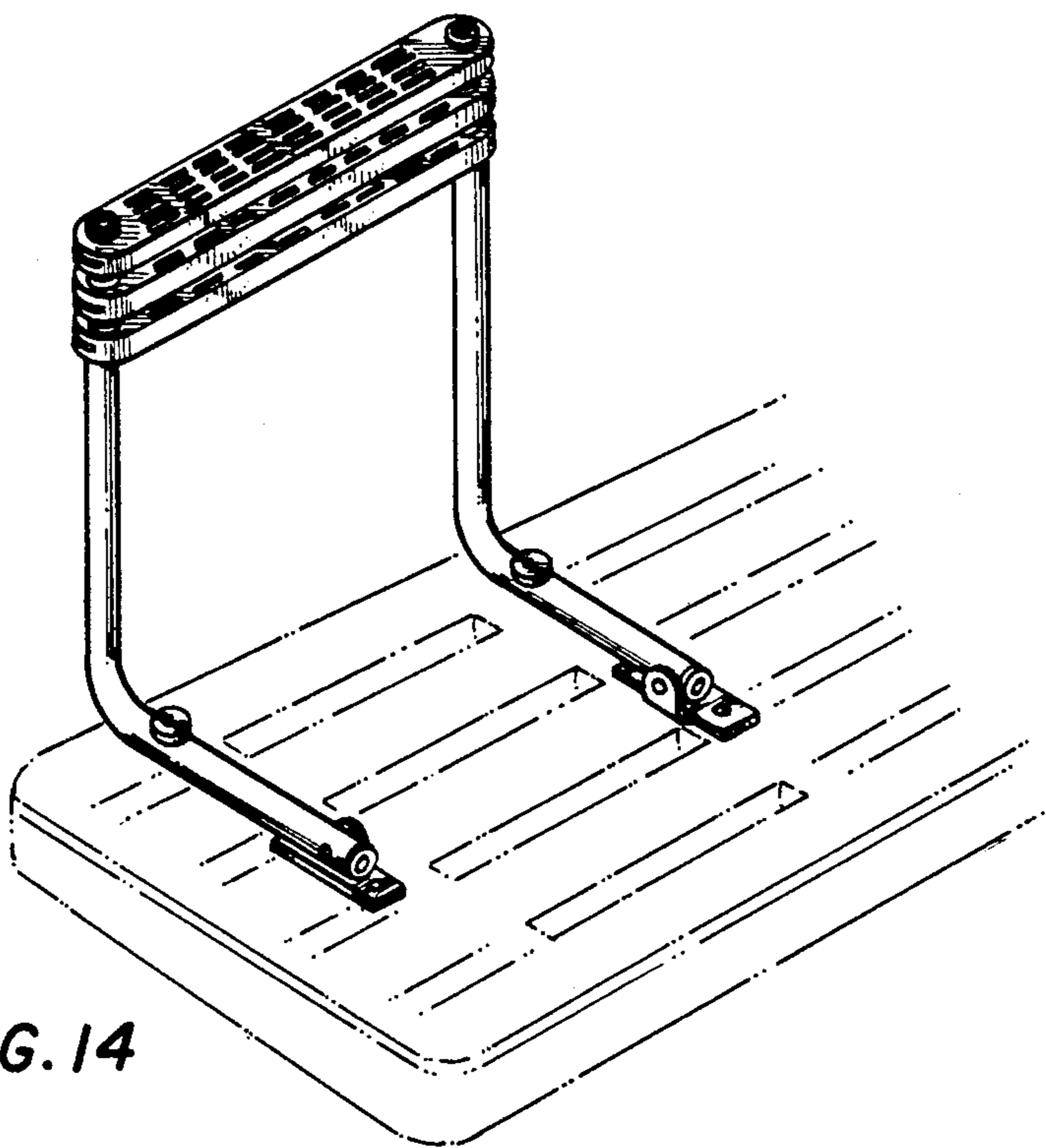

FIG. 14