



US00D331218S

United States Patent [19]

[11] Patent Number: **Des. 331,218**

Masters

[45] Date of Patent: **** Nov. 24, 1992**

[54] AUTOMOBILE BODY REAR END UNIT

OTHER PUBLICATIONS

[76] Inventor: **Robert R. Masters, 1516 Beltway 8 East, Pasadena, Tex. 77503**

Road & Track, Dec. 1984, front cover, rear end of Ferrari Testa Rossa.

[**] Term: **14 Years**

Automobile designed and produced by Robert R. Masters on or about March of 1984 as shown on Exhibit A hereto.

[21] Appl. No.: **615,821**

Primary Examiner—James M. Gandy

[22] Filed: **Nov. 16, 1990**

[57] CLAIM

[52] U.S. Cl. **D12/196; D12/92**

The ornamental design for a automobile body rear end unit, as shown.

[58] Field of Search **D12/196, 92, 91; 296/195, 196, 197, 185**

DESCRIPTION

[56] References Cited

FIG. 1 is a perspective view of the top, rear and one side of an automobile body rear end unit showing my new design;

U.S. PATENT DOCUMENTS

- D. 212,152 9/1968 Haga D12/92
- D. 308,031 5/1990 Falero D12/91

FIG. 2 is a perspective view of the bottom, front and opposite side thereof; and,

FIG. 3 is a rear elevation view thereof.

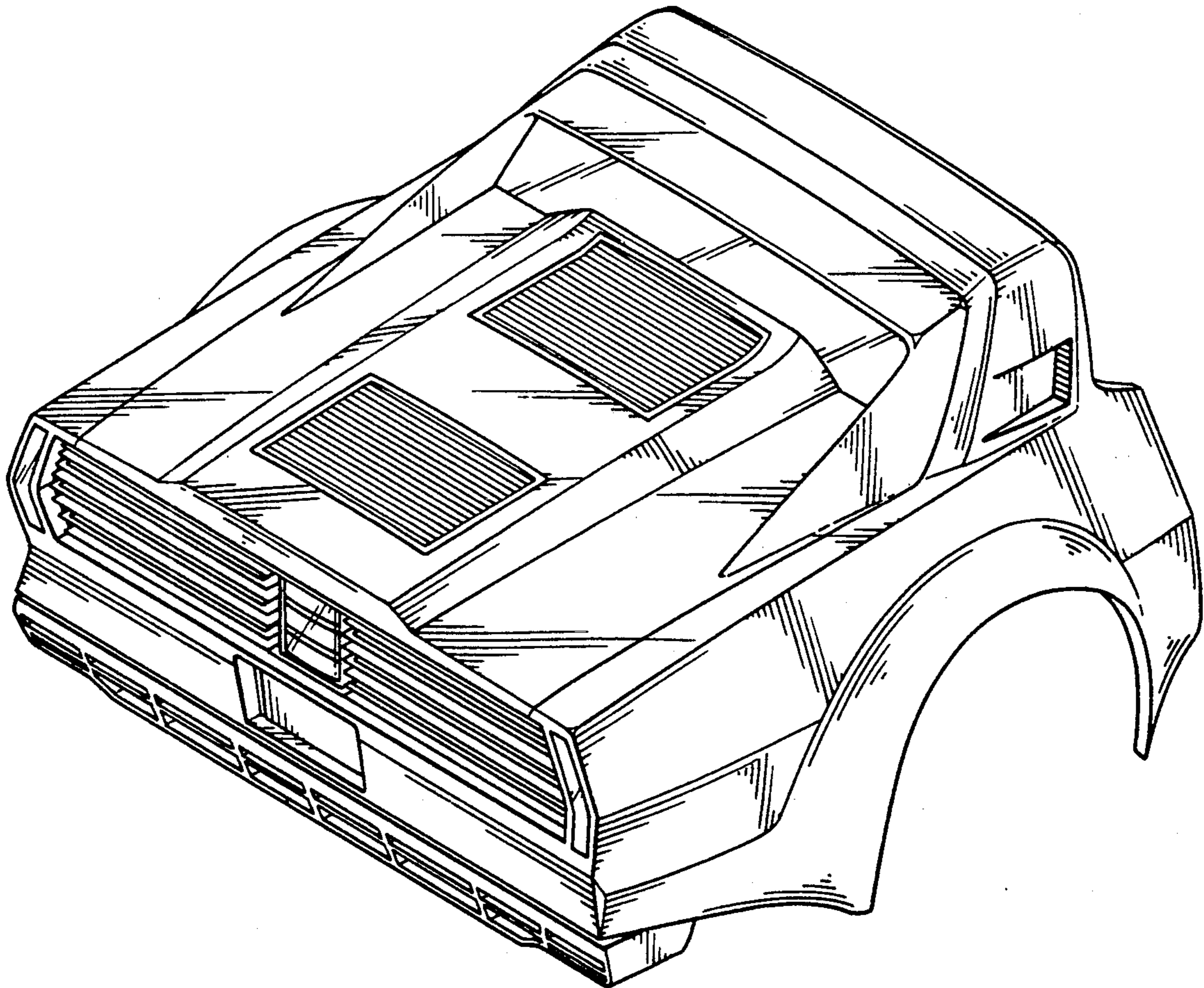

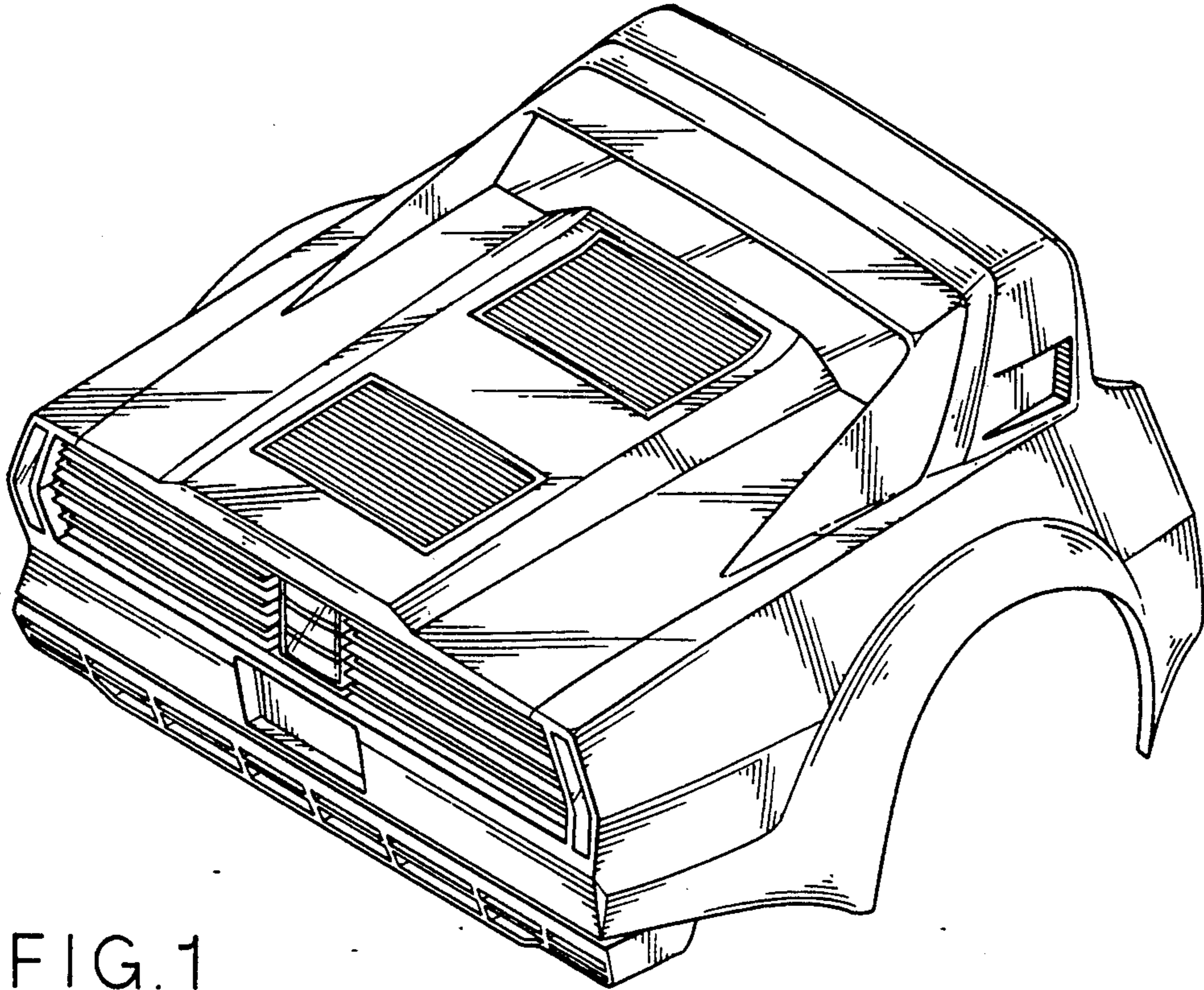

FIG. 1

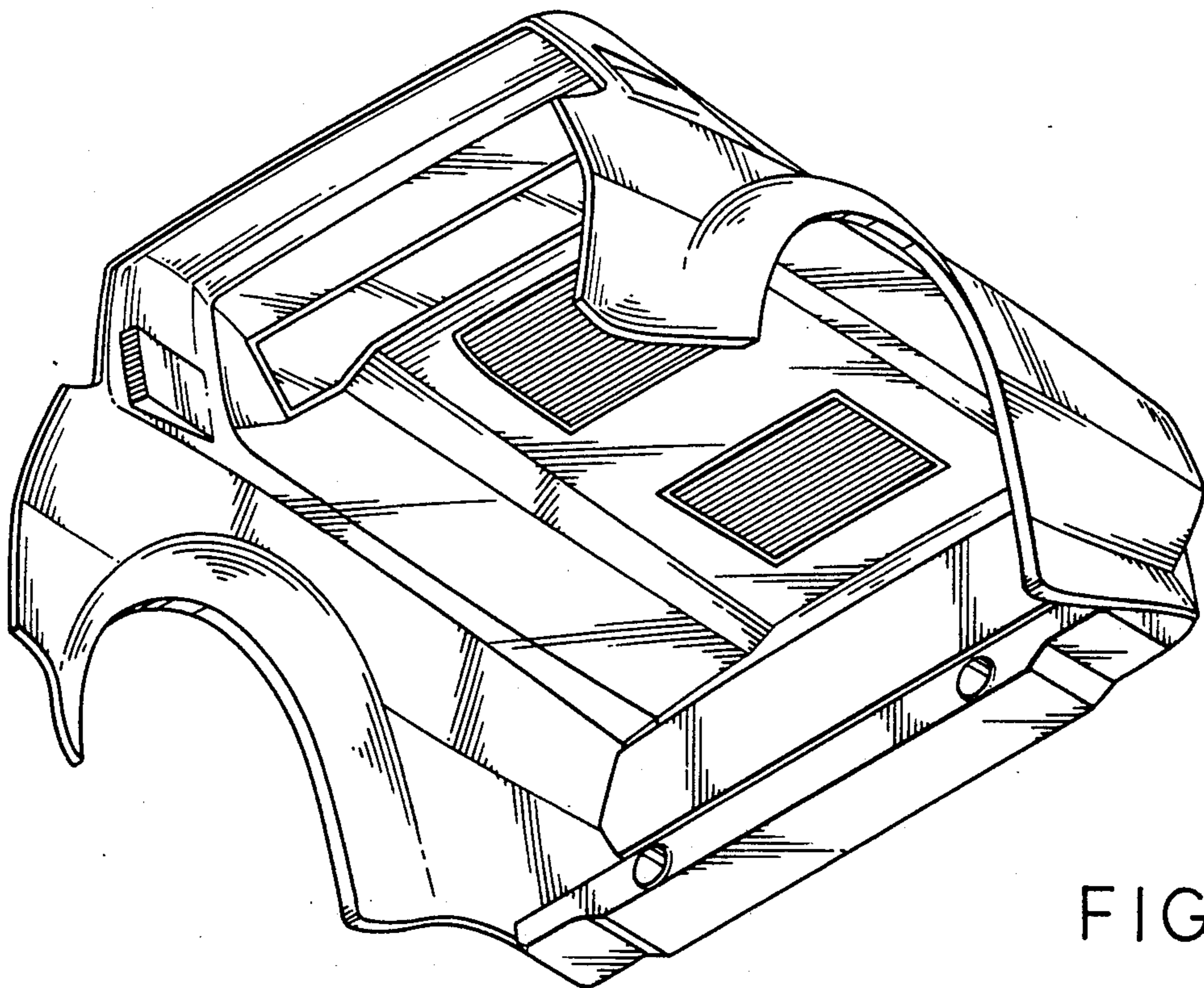

FIG. 2

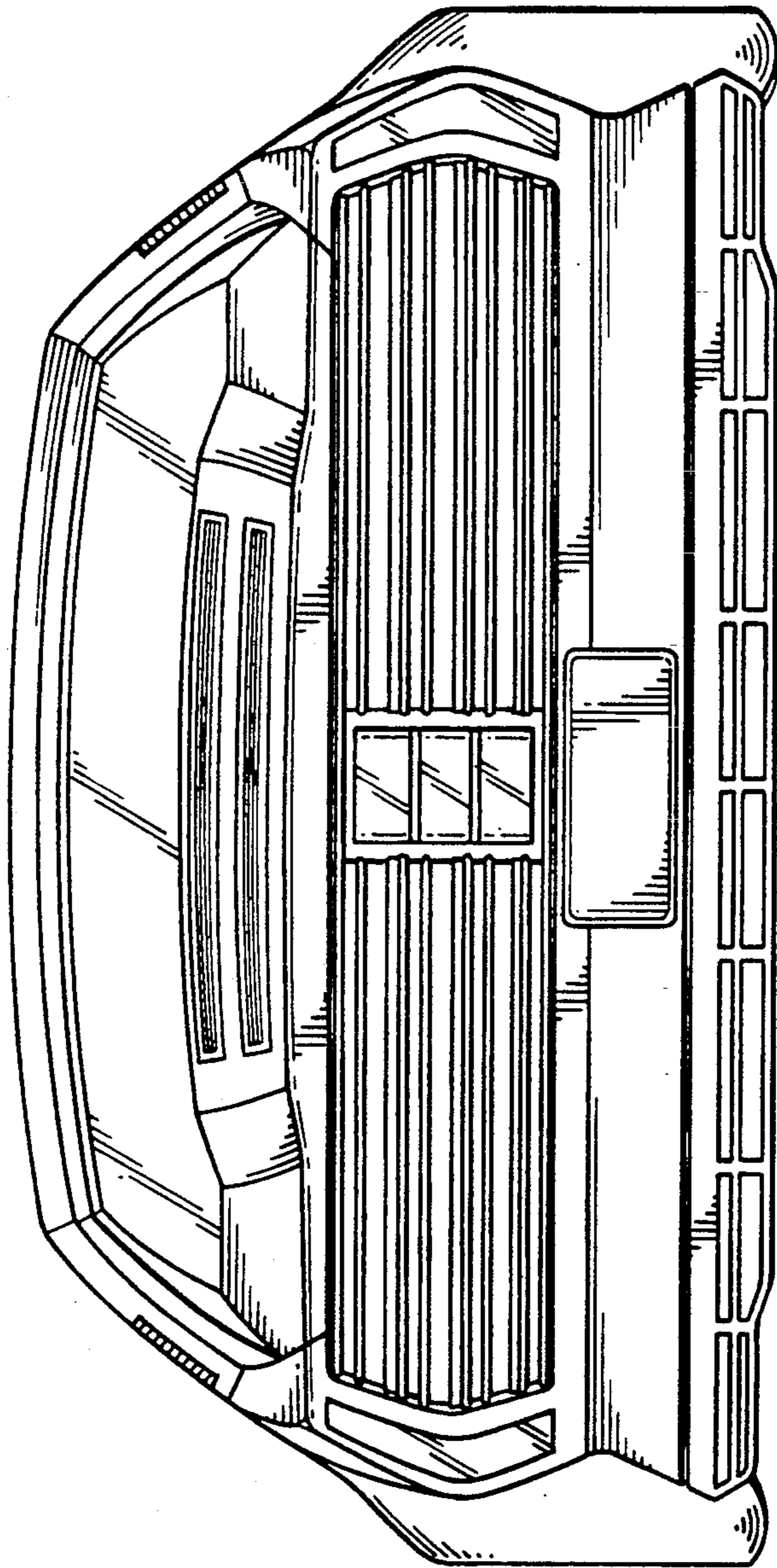

FIG. 3