



US00D331208S

United States Patent [19]

[11] Patent Number: **Des. 331,208**

Peebles et al.

[45] Date of Patent: **** Nov. 24, 1992**

[54] **COMBINED CAR SEAT AND STROLLER**

4,118,052 10/1978 Cabagnero 280/642
4,157,839 6/1979 Lahti et al. 280/642

[76] Inventors: **Mark T. Peebles; Carmen R. Peebles,**
both of 10816 NE. 47th St.,
Vancouver, Wash. 98682

Primary Examiner—Kay H. Chin
Attorney, Agent, or Firm—Leon Gilden

[**] Term: **14 Years**

[57] **CLAIM**

[21] Appl. No.: **544,356**

The ornamental design for a combined car seat and stroller, as shown and described.

[22] Filed: **Jun. 27, 1990**

DESCRIPTION

[52] U.S. Cl. **D12/129; D12/128**

[58] Field of Search **D12/128, 129, 130, 132,**
D12/133; 280/642, 650, 643, 644, 647, 648, 649;
297/429, 437, 377; D6/333

FIG. 1 is a front elevational view of the combined car seat and stroller showing my new design;
FIG. 2 is a rear elevational view thereof;
FIG. 3 is a left side elevational view thereof;
FIG. 4 is a right side elevational view thereof;
FIG. 5 is a top plan view thereof;
FIG. 6 is a bottom plan view thereof;
FIG. 7 is a right side elevational view thereof with the seat portion detached from the stroller frame; and,
FIG. 8 is a top and front perspective view thereof.

[56] **References Cited**

U.S. PATENT DOCUMENTS

D. 288,678 3/1987 Jane D12/129
D. 288,913 3/1987 Hawkes D12/129
4,108,468 8/1978 Orlanski 280/650

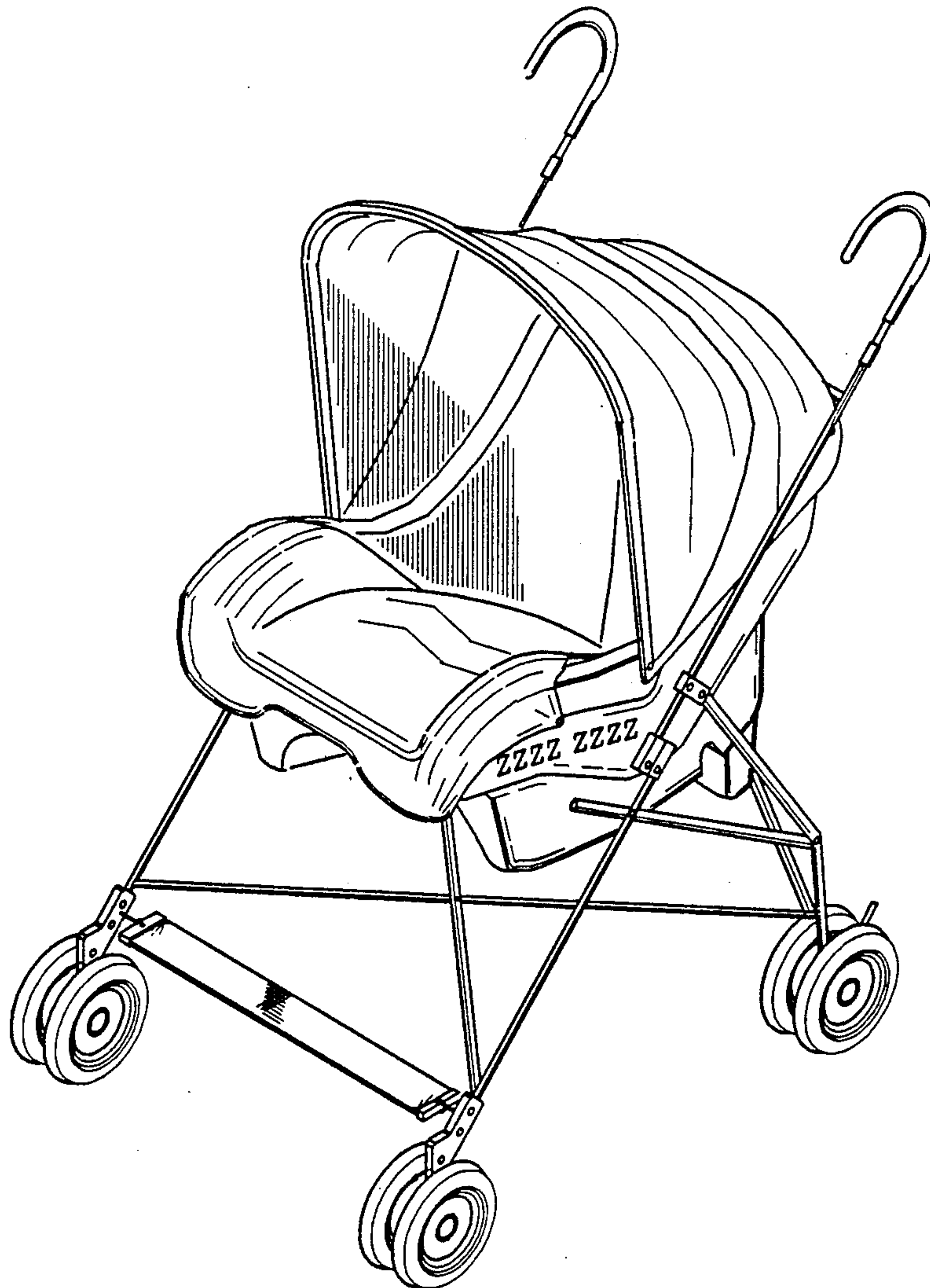

FIG. 1

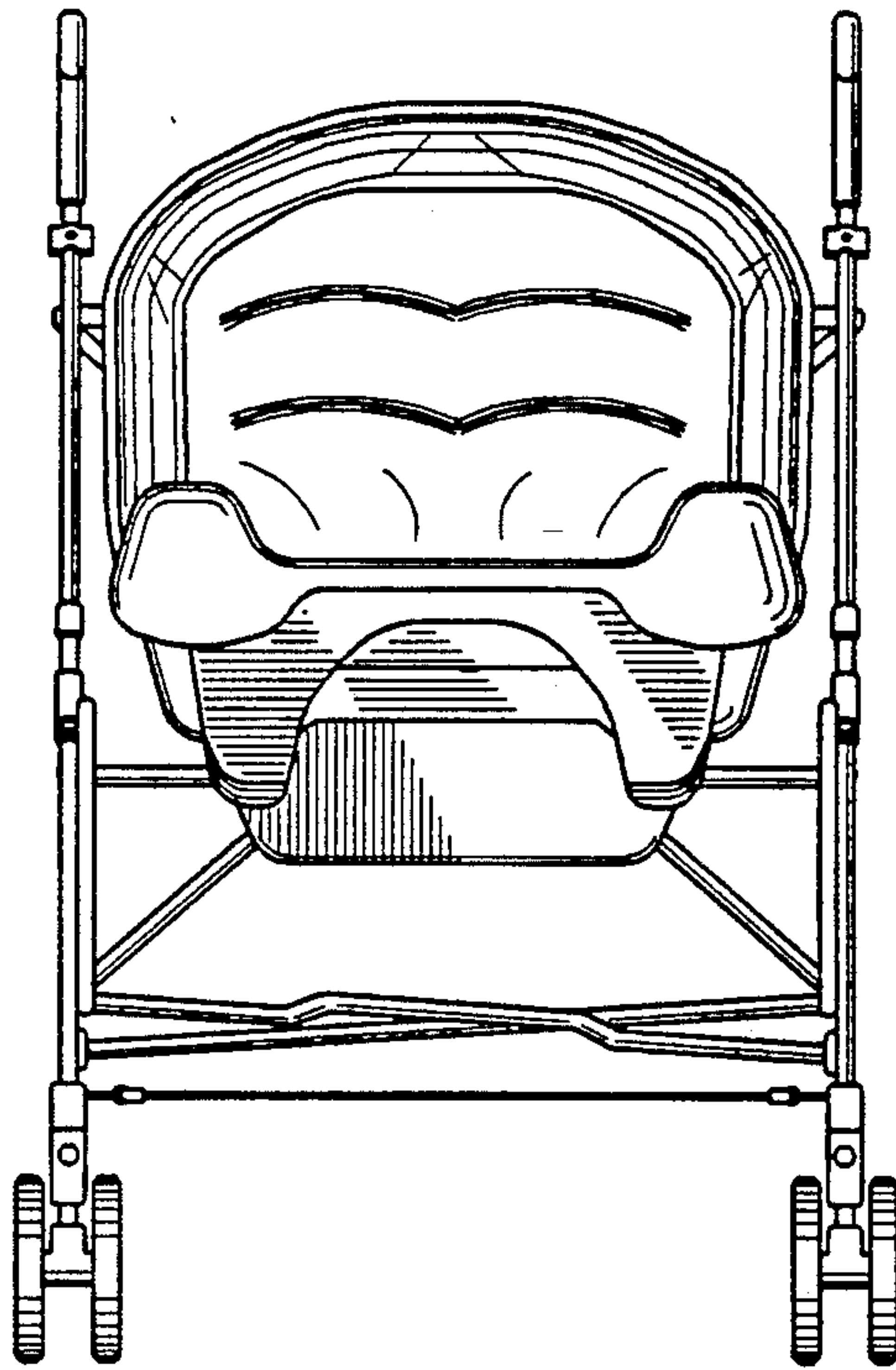

FIG. 2

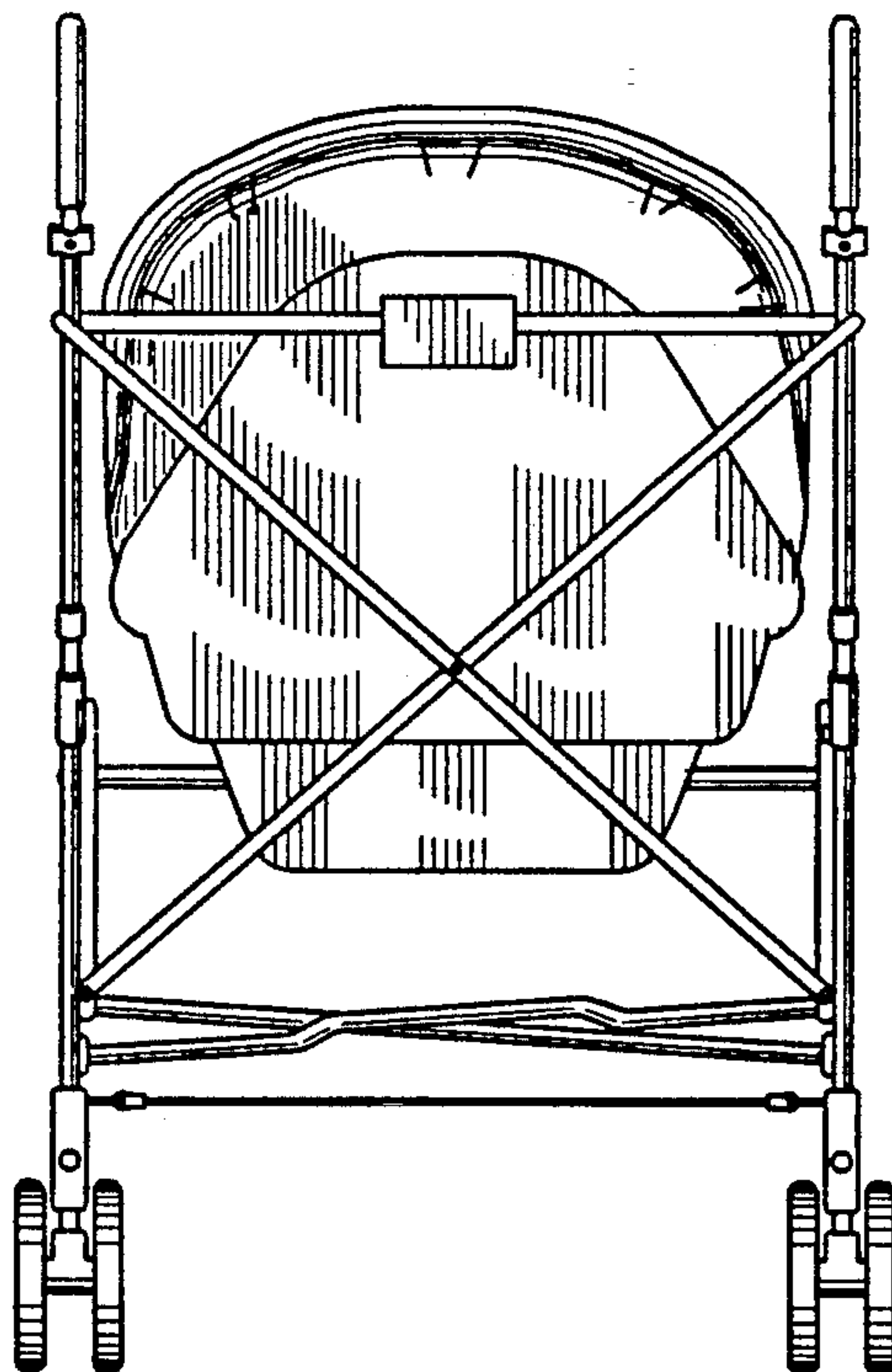

FIG. 3

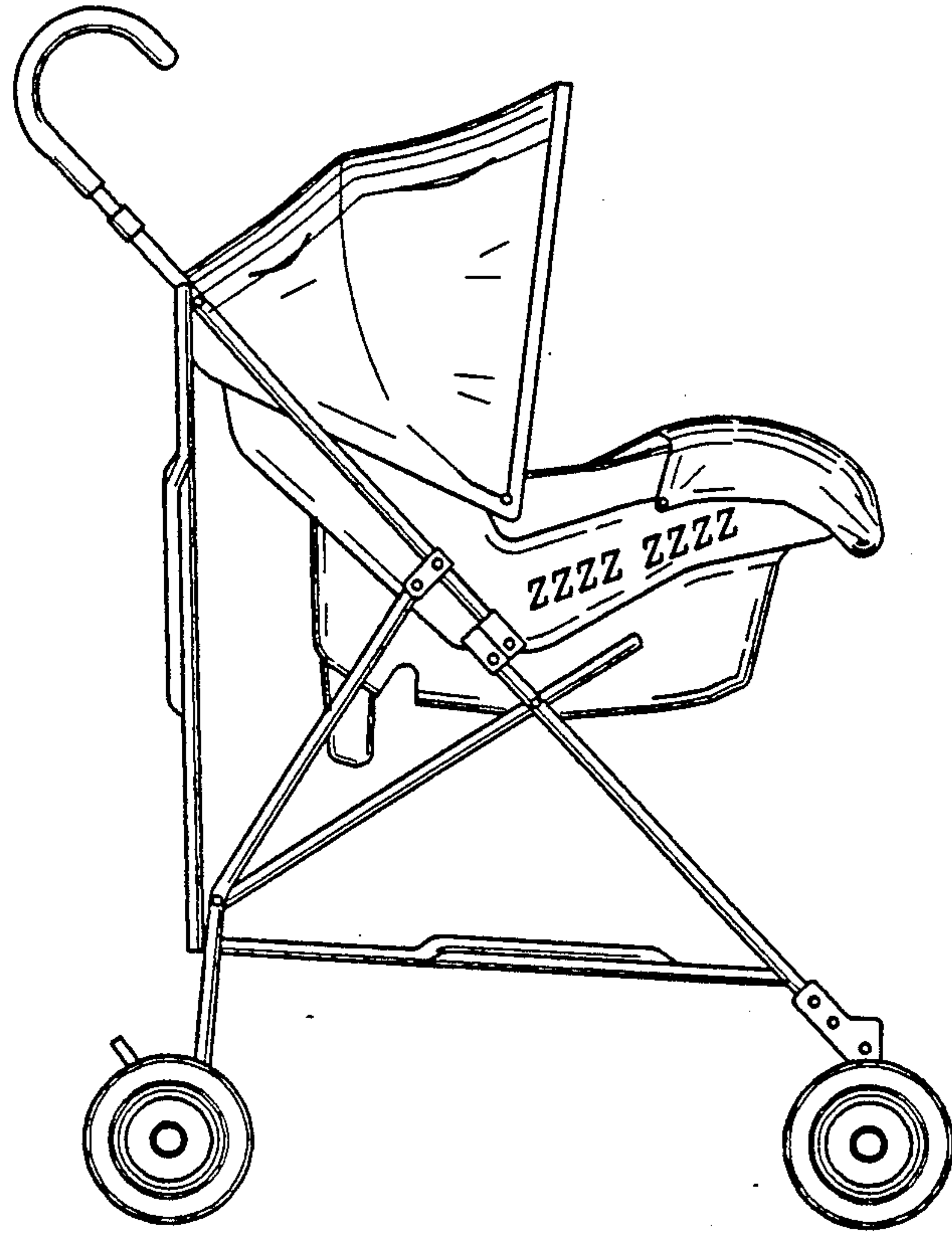

FIG. 4

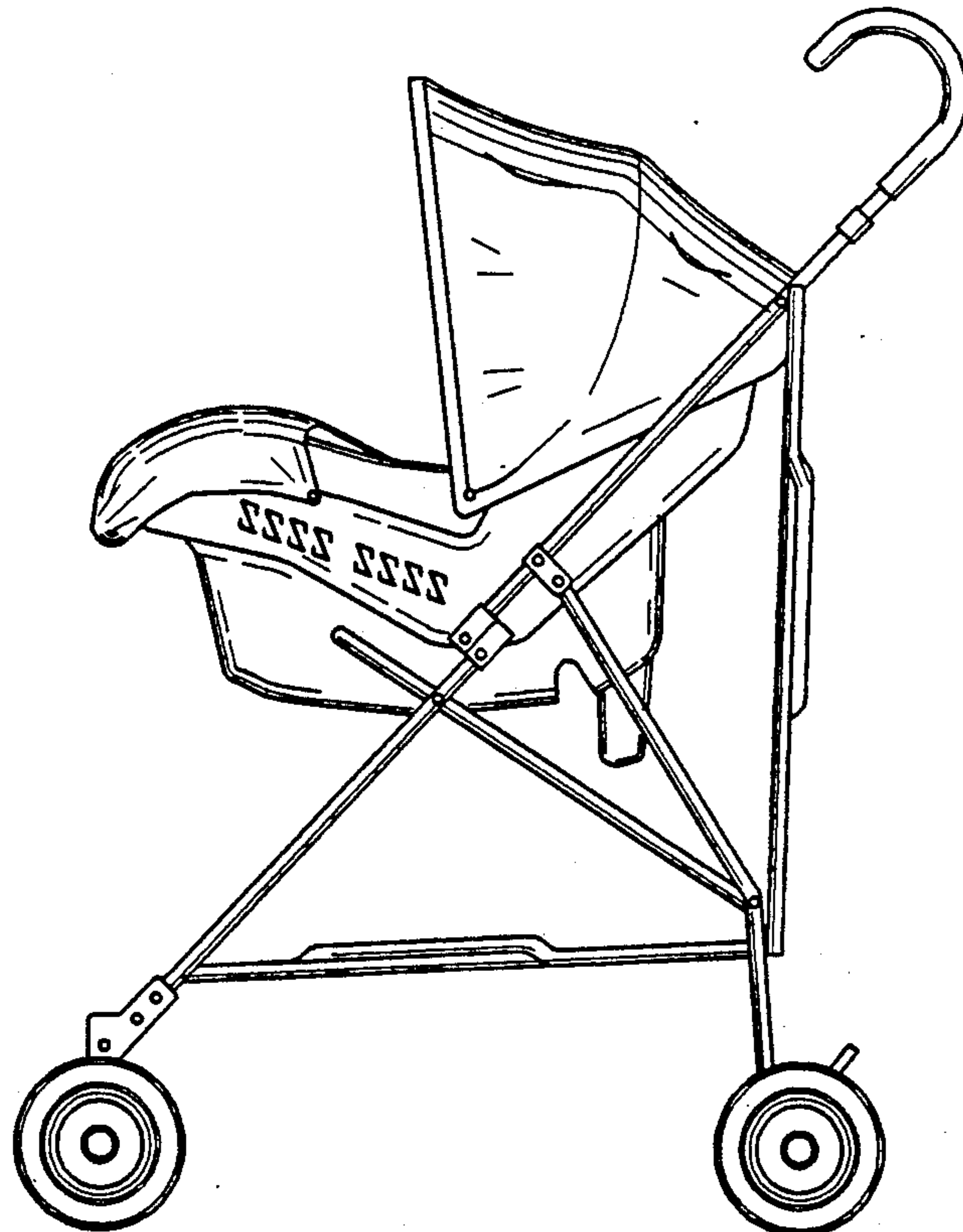

FIG. 5

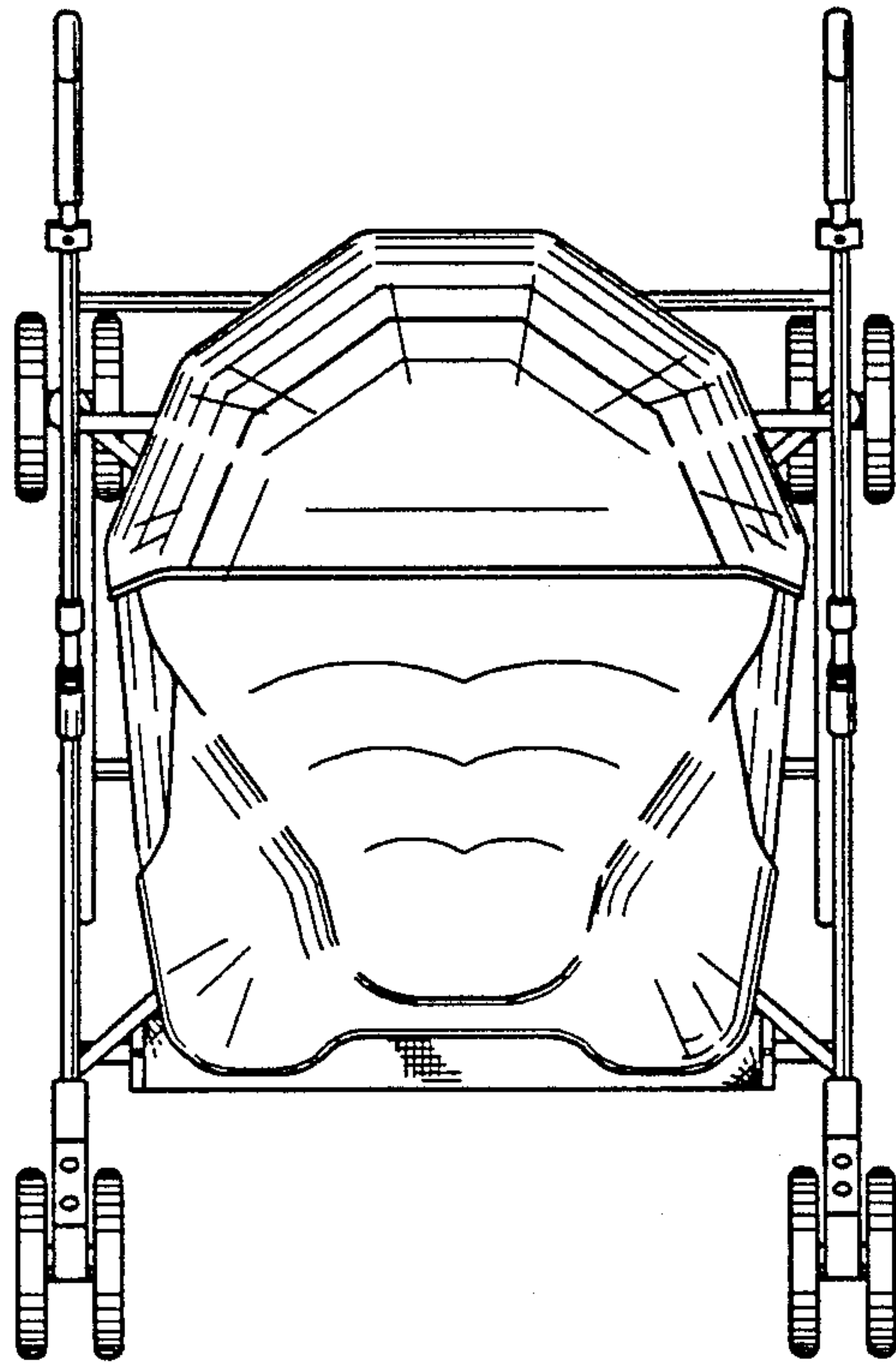

FIG. 6

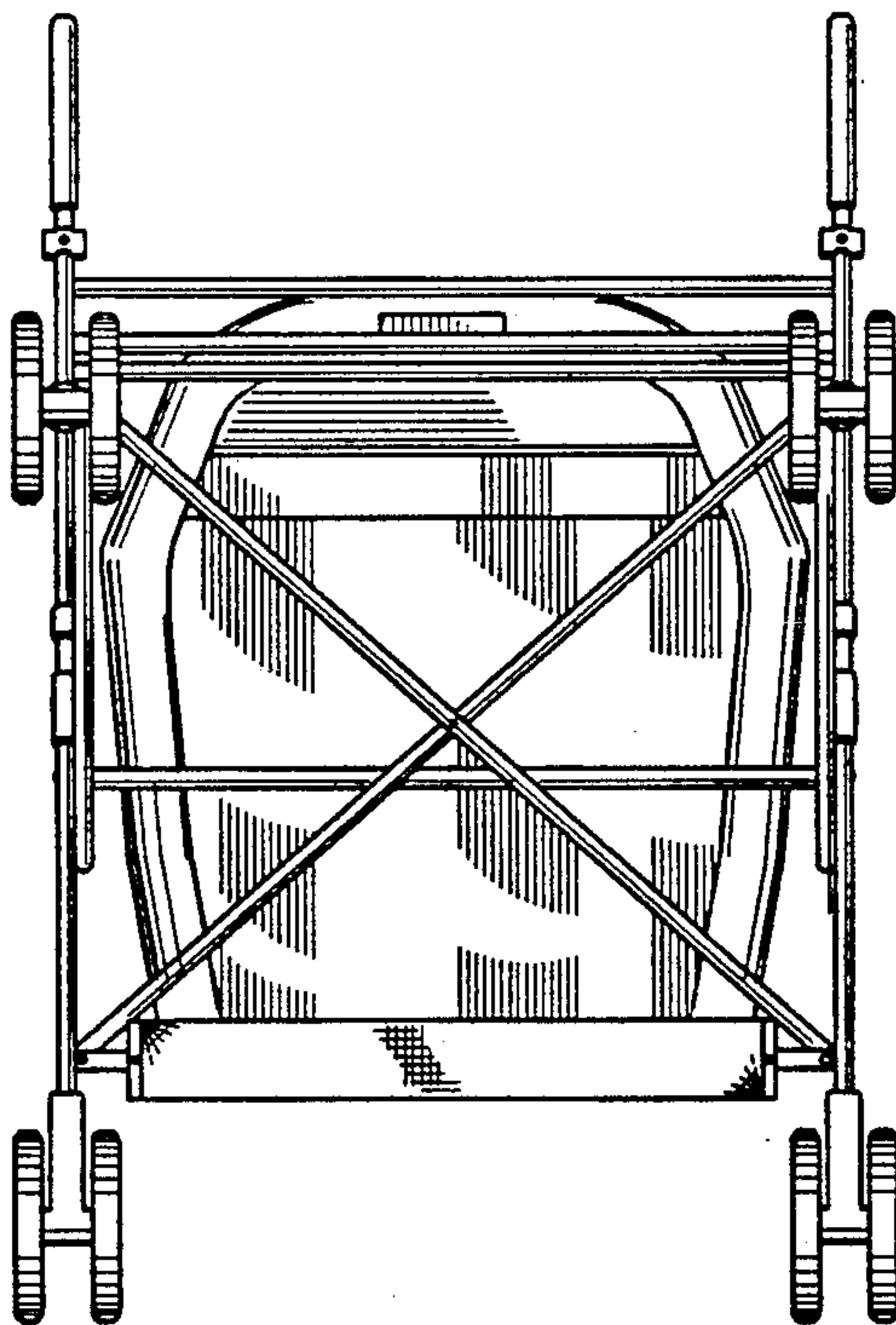

FIG. 7

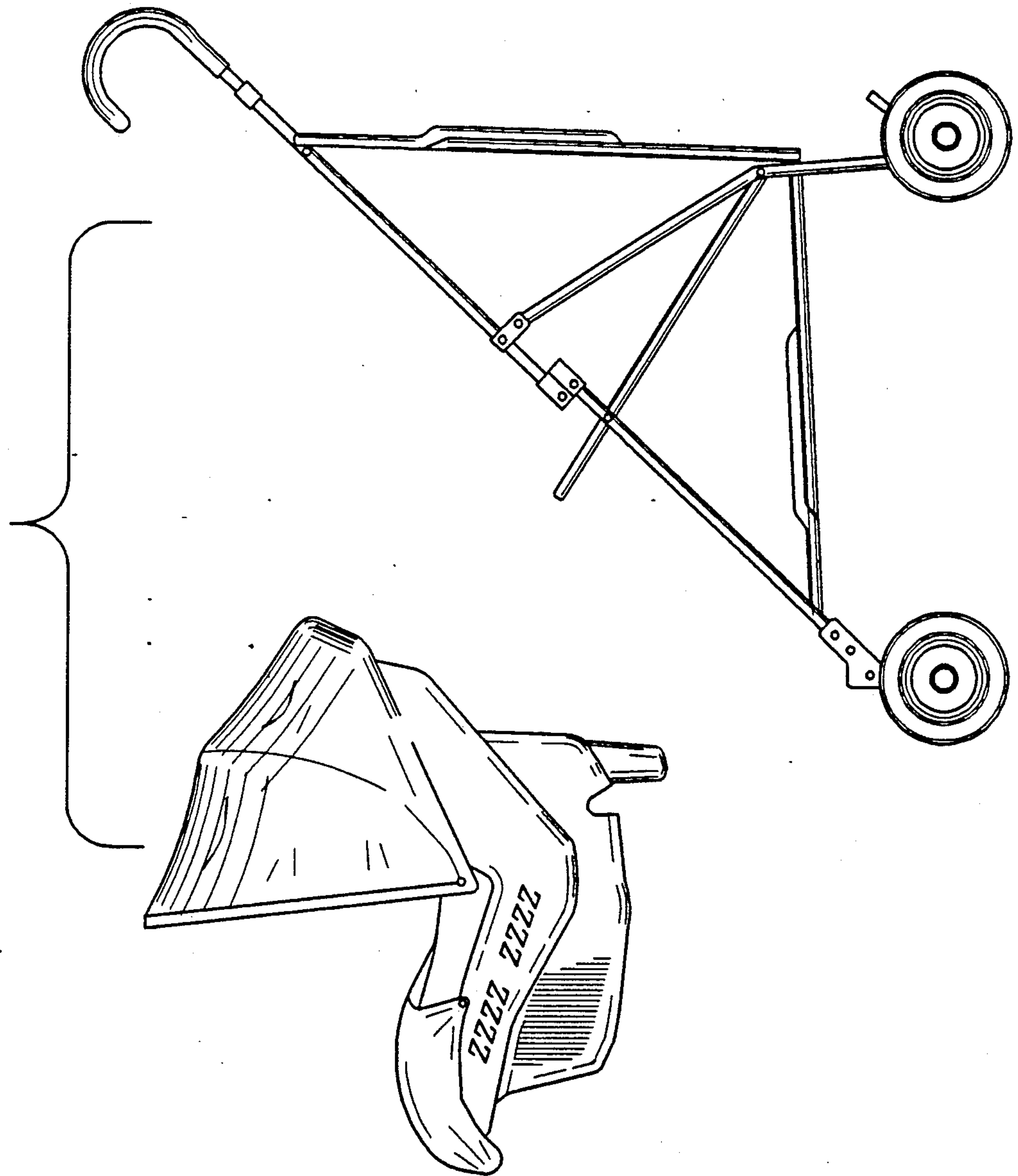

FIG. 8

