



US00D331137S

# United States Patent [19]

[11] Patent Number: **Des. 331,137**

DeLaura

[45] Date of Patent: **\*\* Nov. 17, 1992**

[54] **BOAT BOARDING RAMP**

[76] Inventor: **Frederick E. DeLaura**, Spring St.,  
Rte. 3, South Salem, N.Y. 10304

[\*\*] Term: **14 Years**

[21] Appl. No.: **543,053**

[22] Filed: **Jun. 25, 1990**

[52] U.S. Cl. .... **D34/32; D12/317**

[58] Field of Search ..... **D34/32; D25/62, 61;**  
**D12/317; 414/537; 114/343, 344, 362; 14/71.1**

[56] **References Cited**

**U.S. PATENT DOCUMENTS**

|            |         |               |       |             |
|------------|---------|---------------|-------|-------------|
| D. 191,161 | 8/1961  | Bigelow       | ..... | D25/61      |
| D. 246,638 | 12/1977 | Hegedus       | ..... | D34/32      |
| D. 299,078 | 12/1988 | Jacobson      | ..... | D12/317 X   |
| 4,068,770  | 1/1978  | Boehringer    | ..... | 414/537     |
| 4,260,282  | 4/1981  | Dorsey et al. | ..... | 114/343 X   |
| 4,538,314  | 9/1985  | Baranowski    | ..... | 114/362 X   |
| 4,696,250  | 9/1987  | Antonides     | ..... | 114/343     |
| 4,699,247  | 10/1987 | Clarke        | ..... | 248/188.2 X |

*Primary Examiner*—Wallace R. Burke

*Assistant Examiner*—H. Baynham  
*Attorney, Agent, or Firm*—Ware, Fressola, Van Der  
Sluys & Adolphson

[57] **CLAIM**

The ornamental design for a boat boarding ramp, as shown and described.

**DESCRIPTION**

FIG. 1 is a top plan view of a boat boarding ramp showing my new design;  
 FIG. 2 is a front elevational view thereof;  
 FIG. 3 is a right side elevational view thereof;  
 FIG. 4 is a bottom plan view thereof;  
 FIG. 5 is a rear elevational view thereof;  
 FIG. 6 is a left side elevational view thereof;  
 FIG. 7 is a perspective view thereof;  
 FIG. 8 is a top plan view of a second embodiment of the design shown in FIG. 1;  
 FIG. 9 is a front elevational view thereof;  
 FIG. 10 is a right side elevational view thereof;  
 FIG. 11 is a bottom plan view thereof;  
 FIG. 12 is a rear elevational view thereof;  
 FIG. 13 is a left side elevational view thereof; and,  
 FIG. 14 is a perspective view thereof.

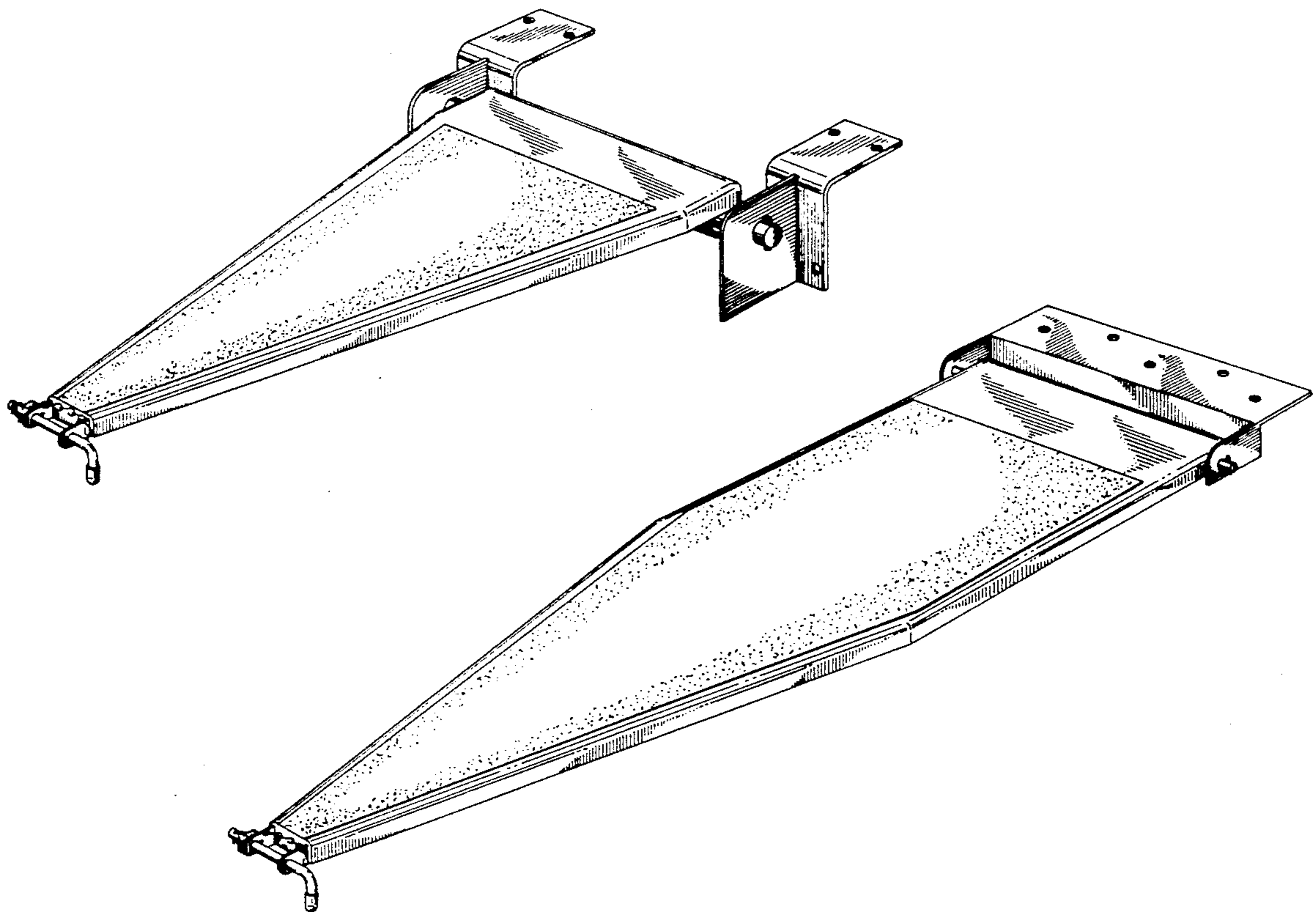

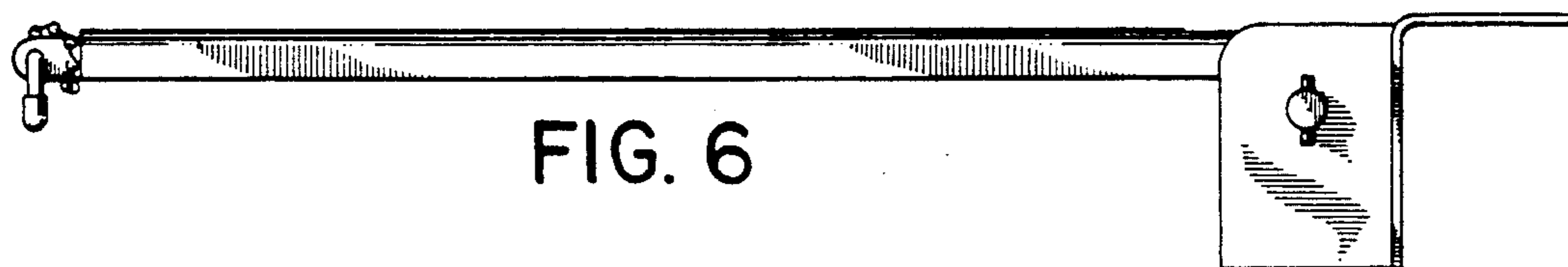
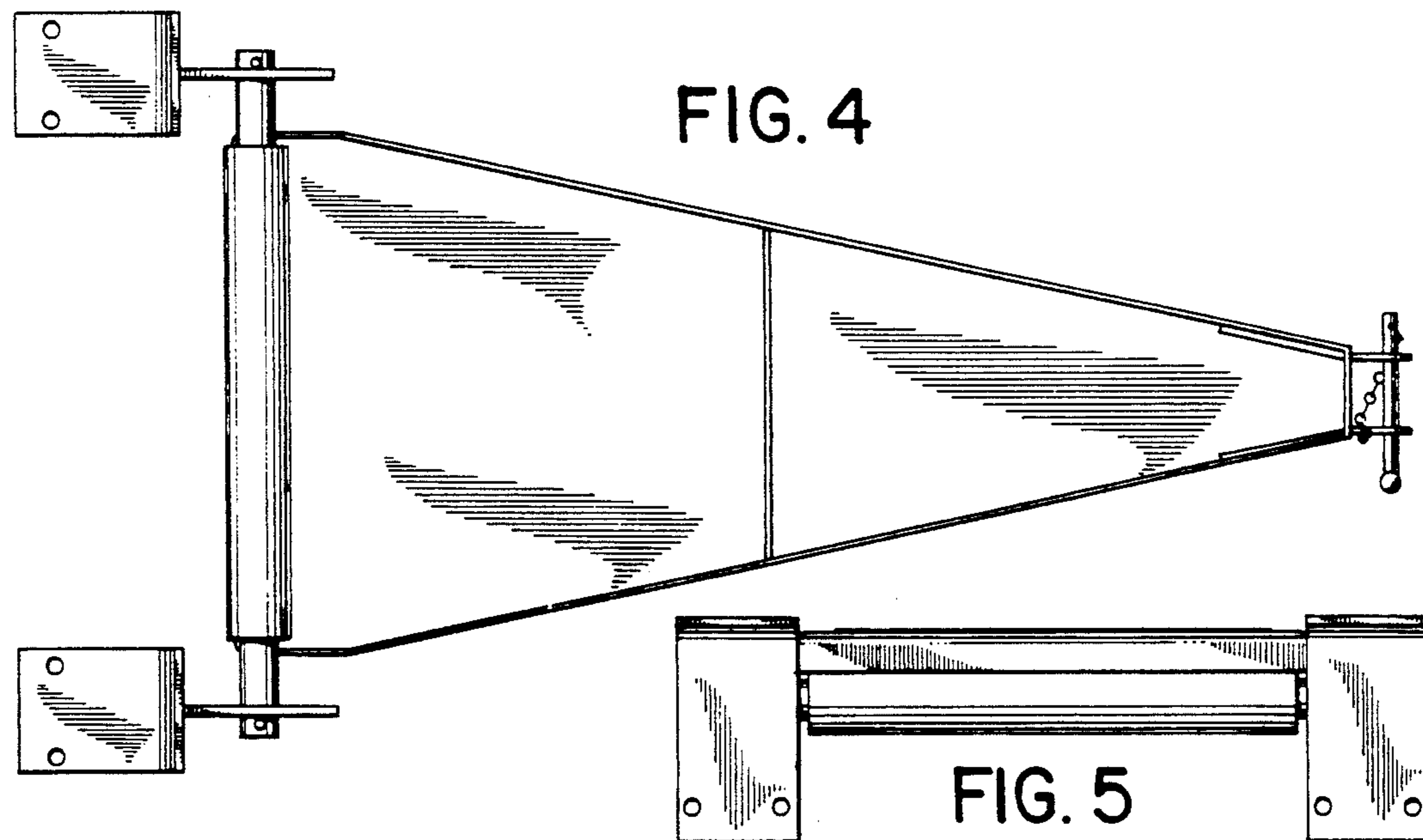
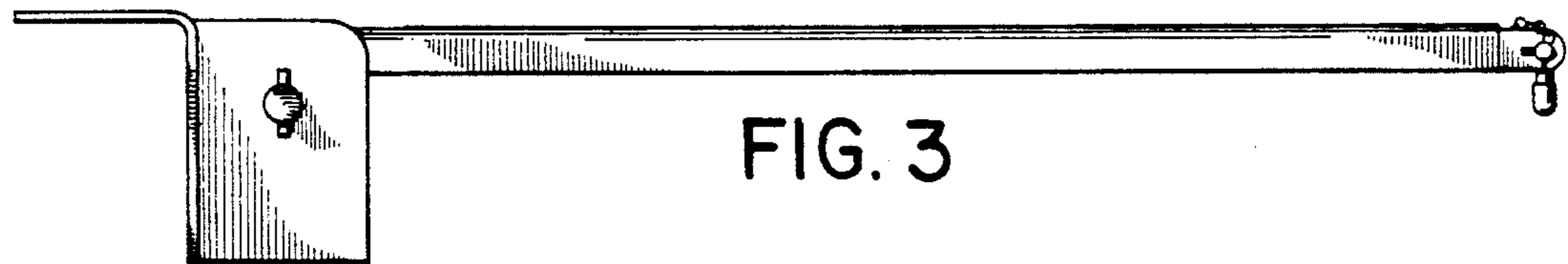
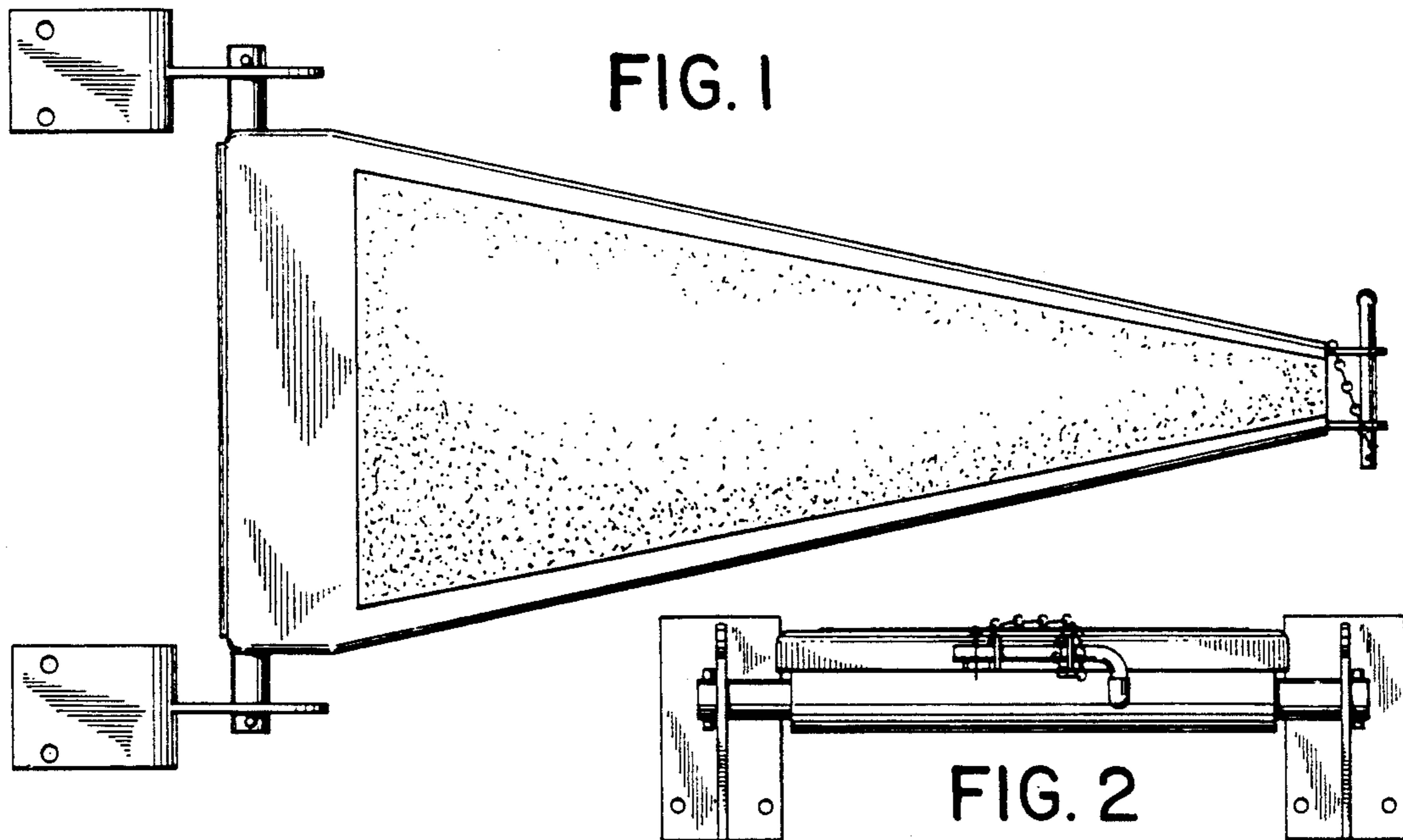

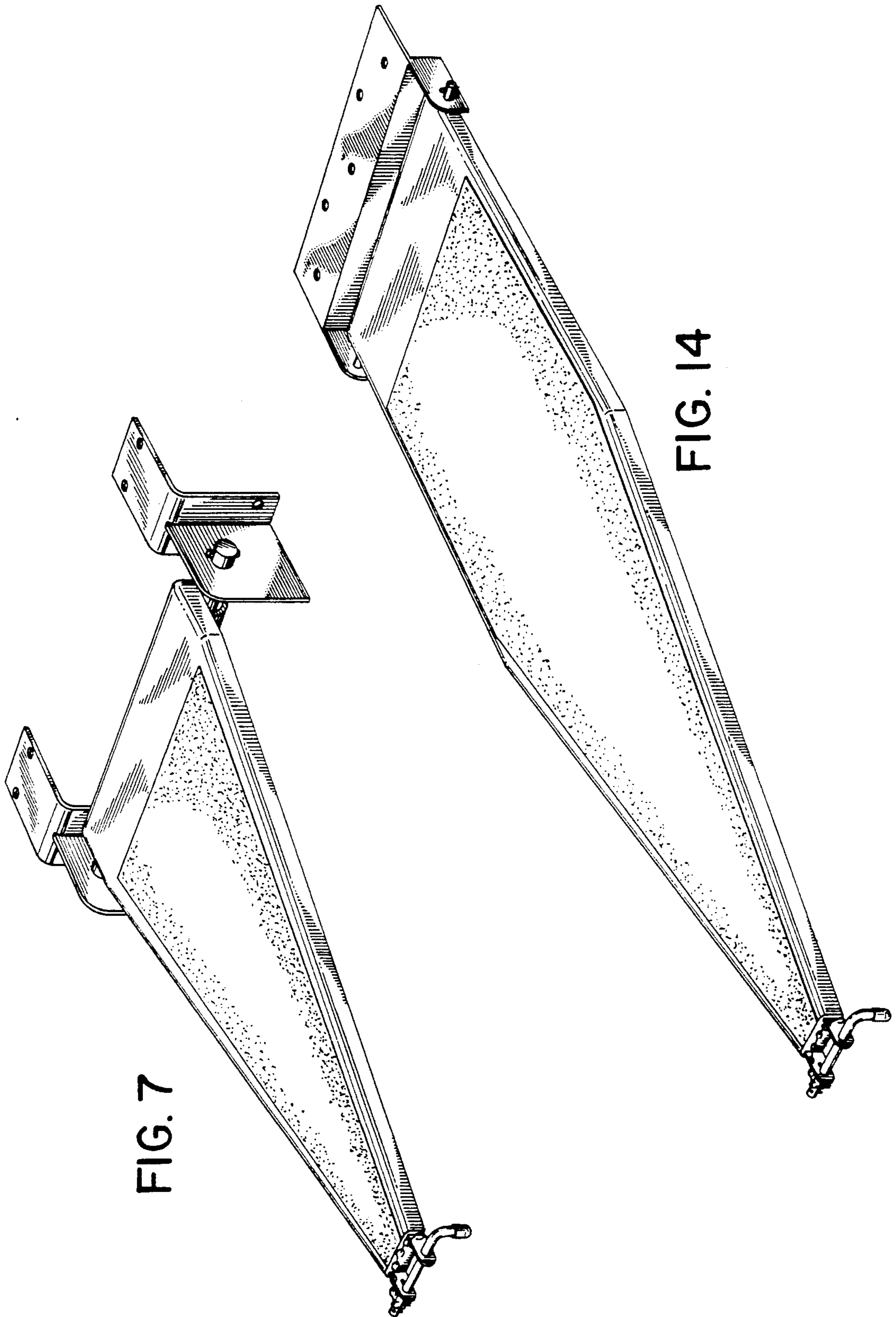

FIG. 7

FIG. 14



