



US00D331135S

# United States Patent [19]

[11] Patent Number: **Des. 331,135**

Lewandowski et al.

[45] Date of Patent: **\*\* Nov. 17, 1992**

- [54] NESTABLE CARGO CART 4,381,870 5/1983 Muellner ..... 280/33.99
- 4,450,968 5/1984 Muellner ..... 211/17
- [75] Inventors: **Mark S. Lewandowski**, White Bear 4,518,072 5/1985 Muellner et al. .... 194/4 D  
4,601,479 7/1986 Reinbold et al. .... 280/33.996  
**Lake; David M. Gessner**, Lino Lakes; 4,733,877 3/1988 Pastien ..... 280/33.99 R  
**Robert C. Anthony**, North Oaks, all  
of Minn.

[73] Assignee: **Smarte Carte, Inc.**, White Bear Lake, Minn.

*Primary Examiner*—Kay H. Chin  
*Attorney, Agent, or Firm*—Merchant, Gould, Smith, Edell, Welter & Schmidt

[\*\*] Term: **14 Years**

### [57] CLAIM

[21] Appl. No.: **721,204**

The ornamental design for a nestable cargo cart, as shown and described.

[22] Filed: **Jun. 24, 1991**

[52] U.S. Cl. .... **D34/18; D34/21**

[58] Field of Search ..... **D34/14, 12, 17, 18, D34/20, 21, 22; 280/33, 996, 47.35, 79.1, 33.991**

### DESCRIPTION

### [56] References Cited

#### U.S. PATENT DOCUMENTS

- D. 206,116 11/1966 Hughes ..... D14/3
- D. 230,142 1/1974 Muellner ..... D12/22
- D. 263,456 3/1982 Muellner ..... D34/18
- 2,992,010 7/1961 Sides ..... 280/33.99

FIG. 1 is a front perspective view of a nestable cargo cart showing our new design;  
FIG. 2 is a top plan view thereof;  
FIG. 3 is a right side elevational view thereof, the left side elevational view being a mirror image of the shown;  
FIG. 4 is a bottom plan view thereof;  
FIG. 5 is a front elevational view thereof; and,  
FIG. 6 is a rear elevational view thereof.

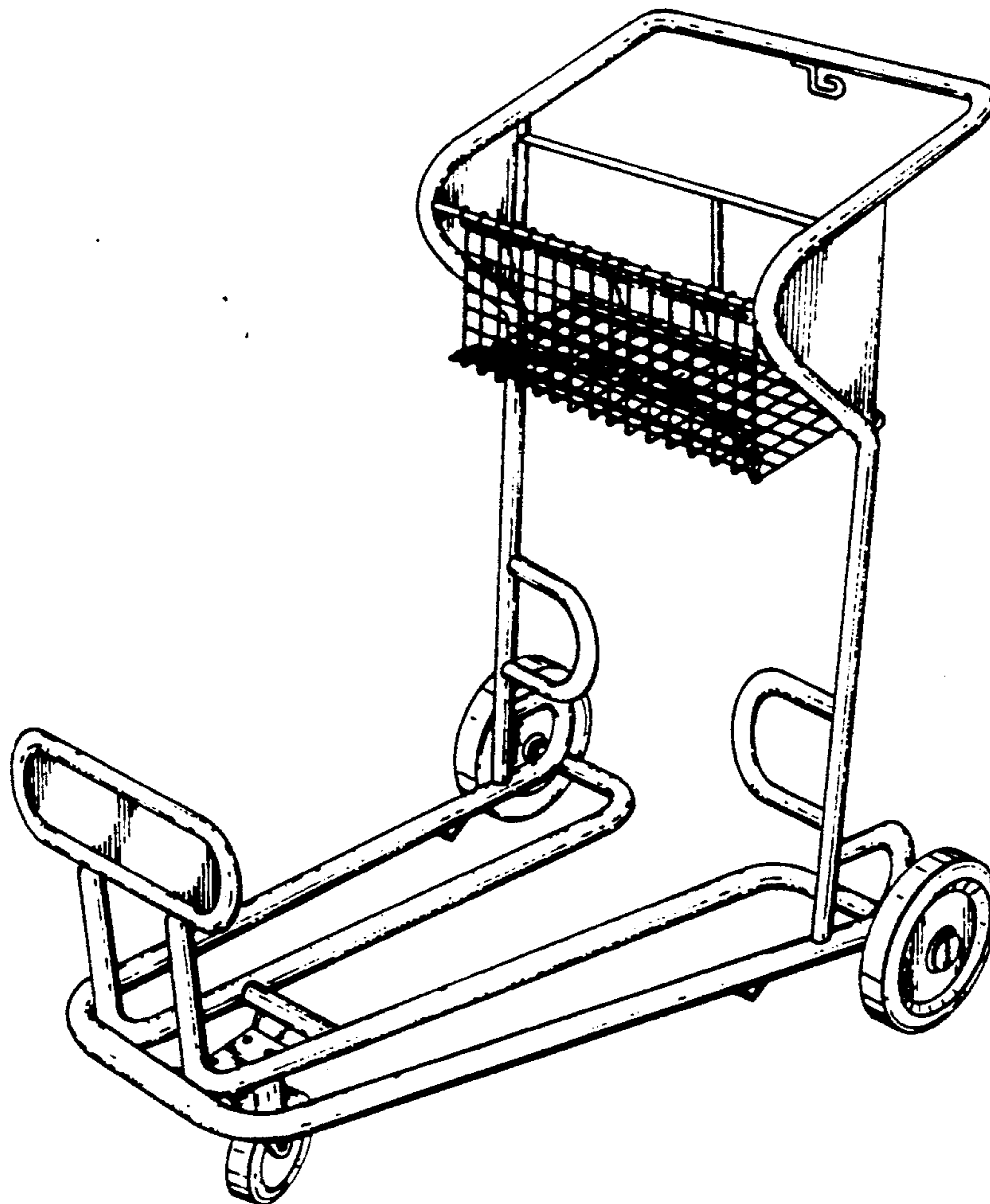

FIG. 1

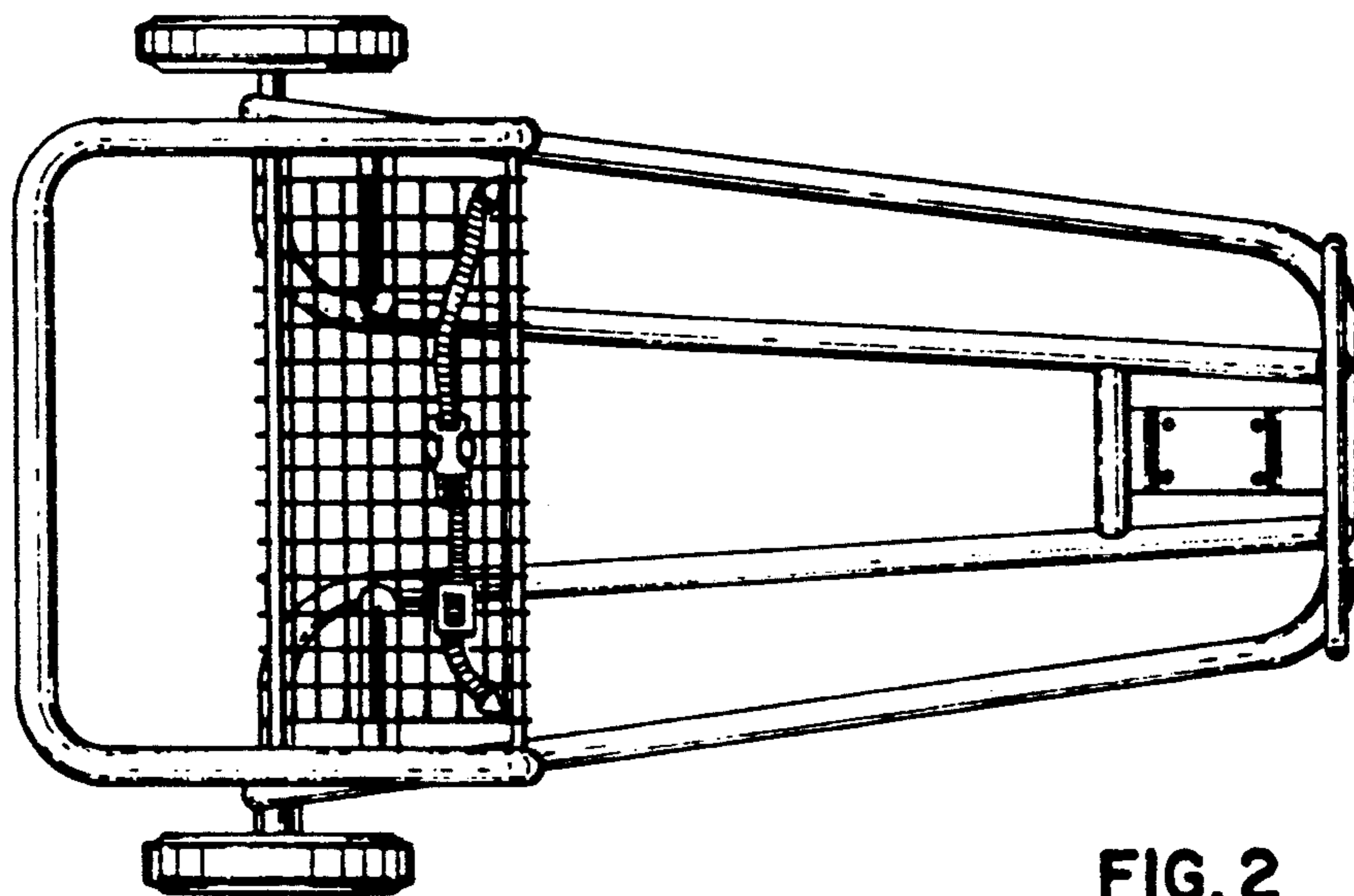
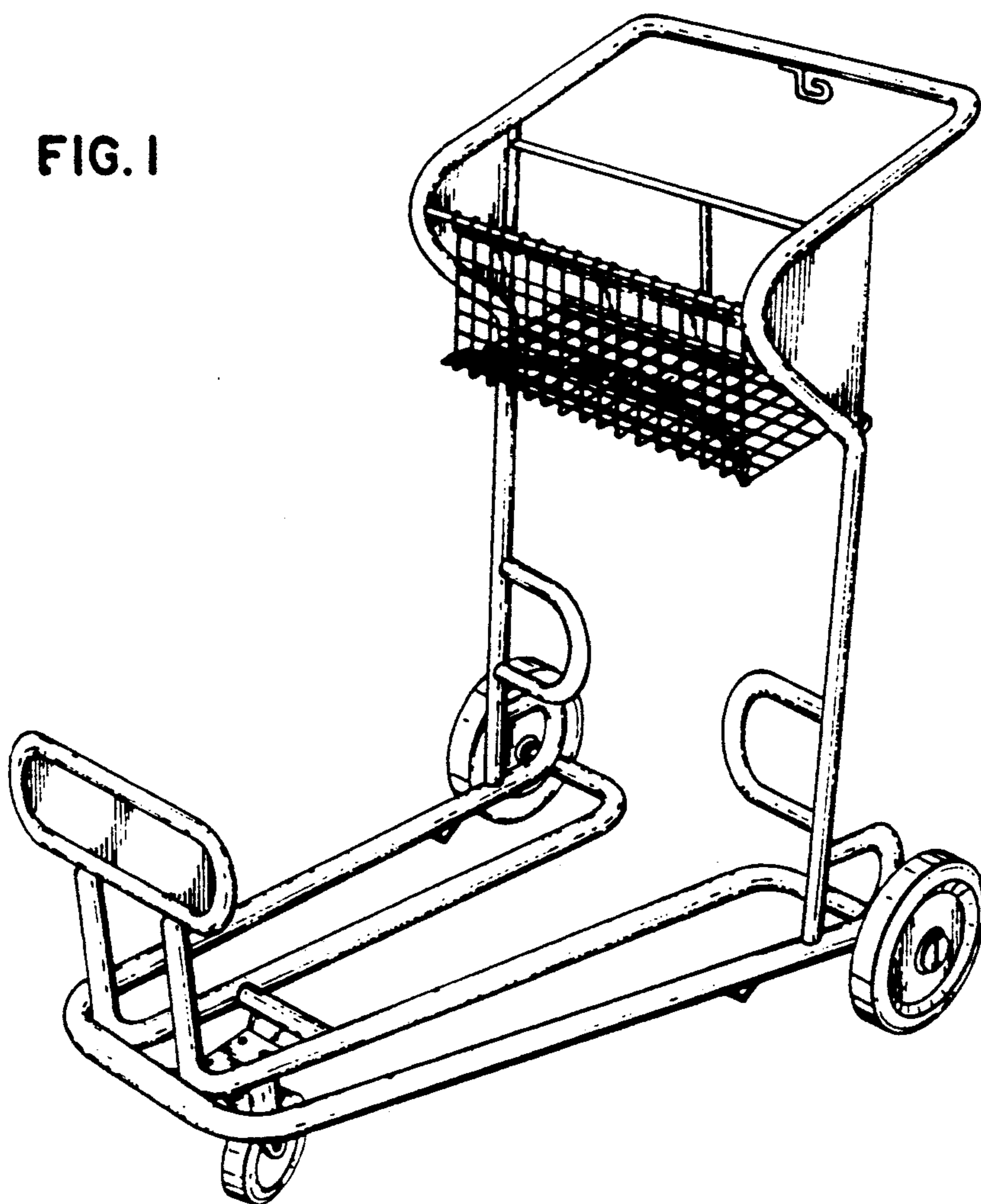

FIG. 2

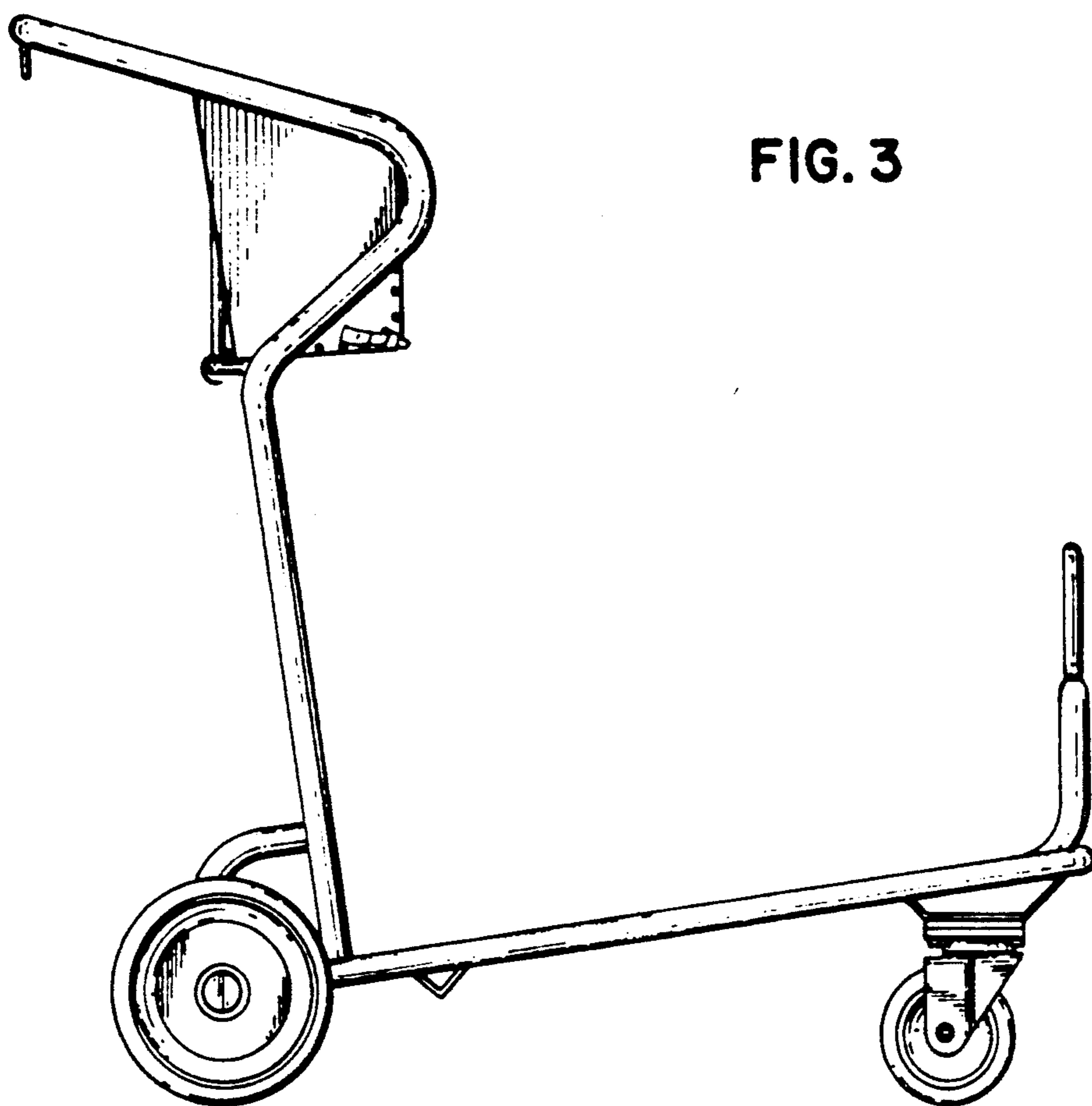

FIG. 3

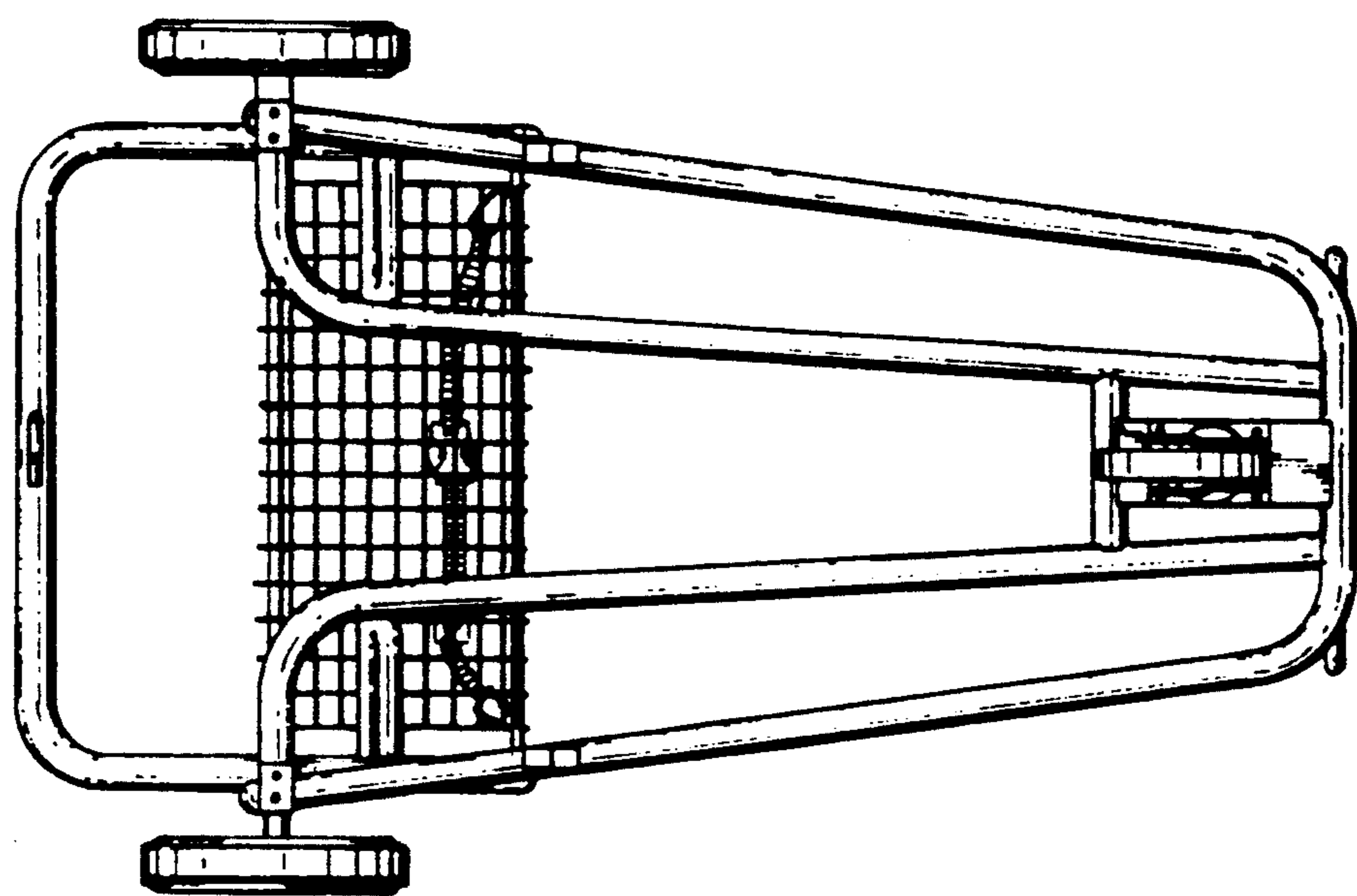

FIG. 4

FIG. 5

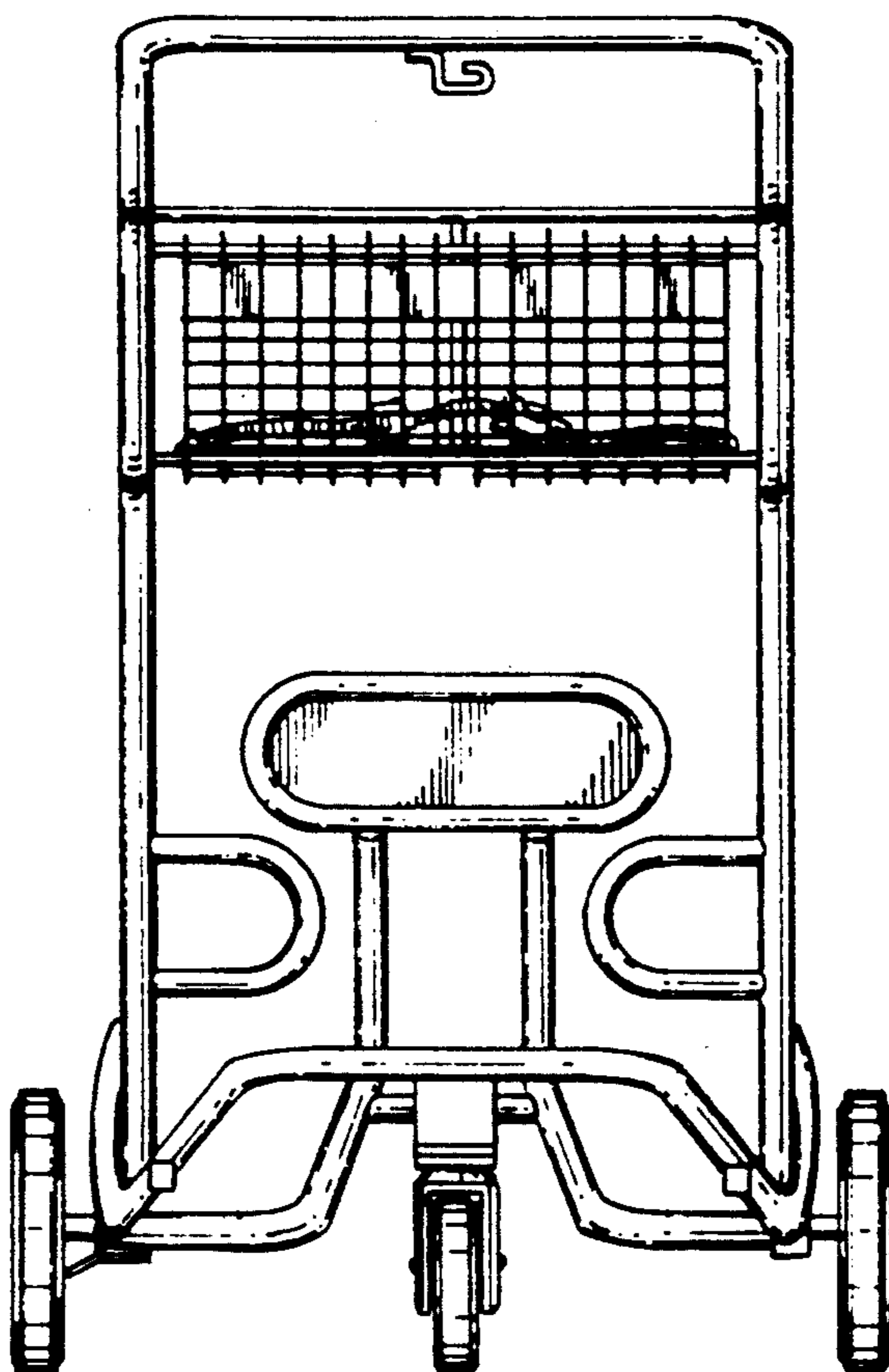

FIG. 6

