



US00D331027S

United States Patent [19]

[11] Patent Number: Des. 331,027

Kitazawa

[45] Date of Patent: ** Nov. 17, 1992

[54] ENGINE TACHOMETER

[75] Inventor: Motoshige Kitazawa, Yokosuka, Japan

[73] Assignee: Oppama Industry Co., Ltd., Kanagawa, Japan

[**] Term: 14 Years

[21] Appl. No.: 447,696

[22] Filed: Dec. 8, 1989

[52] U.S. Cl. D10/98; D10/78

[58] Field of Search D10/78, 98; 73/116; 116/334; 324/156, 158, 170, 379, 402; 340/700, 753

[56] References Cited

U.S. PATENT DOCUMENTS

D. 242,722	12/1976	Bell	D10/78 X
D. 260,085	8/1981	Mitchell	D10/78
D. 268,174	3/1983	Noe	D10/78
D. 310,660	9/1990	Ishida	D14/100
D. 317,417	6/1991	Lin	D10/98
4,694,408	9/1987	Zaleski	73/116 X
4,967,143	10/1990	Raviglione et al.	324/378 X

Primary Examiner—Carmen H. Vales-Lado

Assistant Examiner—Antoine D. Davis
Attorney, Agent, or Firm—Bauer & Schaffer

[57] CLAIM

The ornamental design for an engine tachometer, as shown and described.

DESCRIPTION

FIG. 1 is a front, bottom and right side perspective view of an engine tachometer showing my new design;
 FIG. 2 is a rear elevational view;
 FIG. 3 is a front elevational view;
 FIG. 4 is a top plan view;
 FIG. 5 is a bottom plan view;
 FIG. 6 is a left side elevational view;
 FIG. 7 is a right side elevational view;
 FIG. 8 is a front, bottom and right side perspective view of a second embodiment of FIGS. 1-7 showing my new design;
 FIG. 9 is a rear elevational view;
 FIG. 10 is a front elevational view;
 FIG. 11 is a top plan view;
 FIG. 12 is a bottom plan view;
 FIG. 13 is a left side elevational view; and,
 FIG. 14 is a right side elevational view thereof.
 FIGS. 1 and 8 have been drawn on a slightly enlarged scale with respect to FIGS. 2-7, and 9-14.

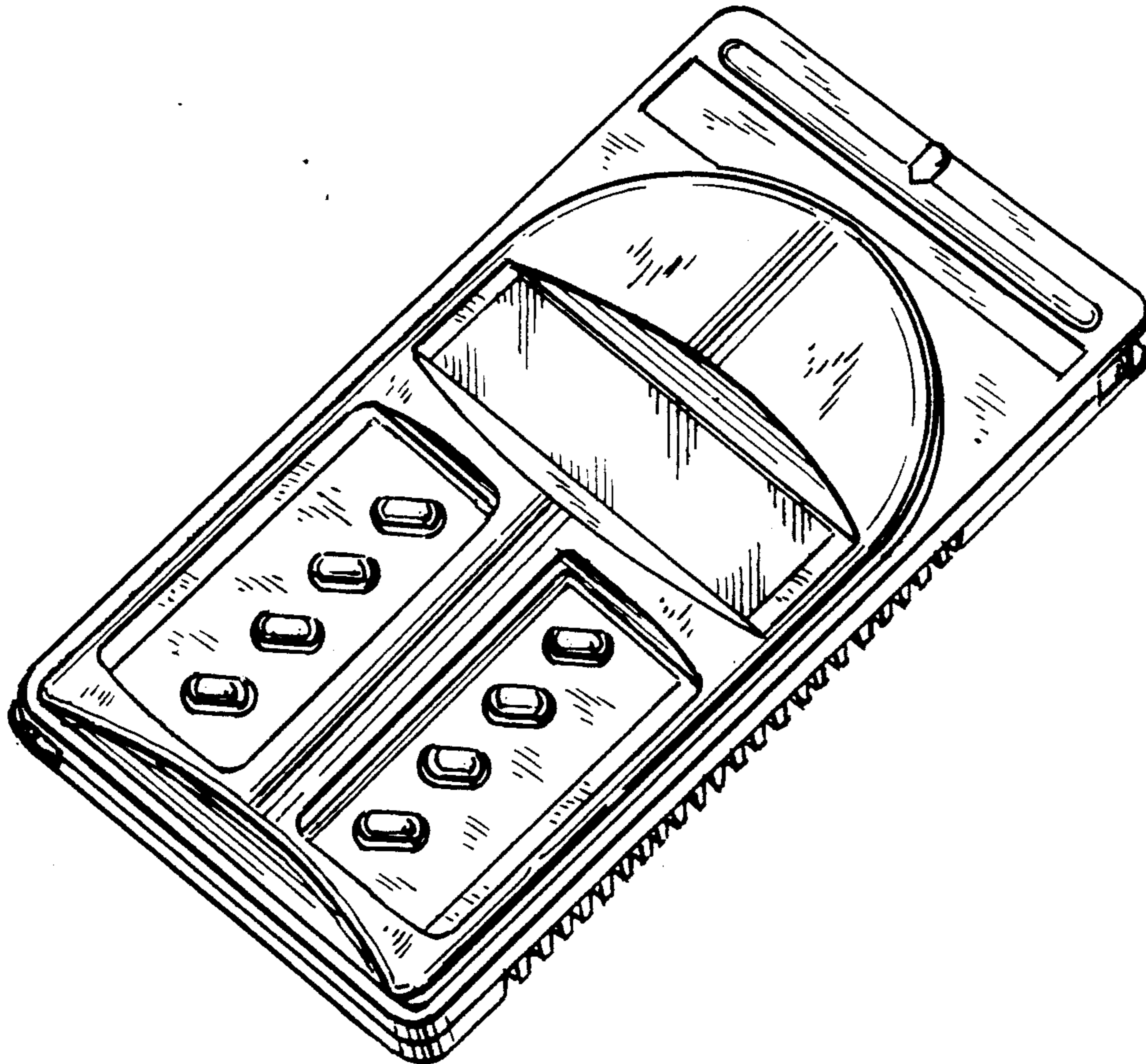

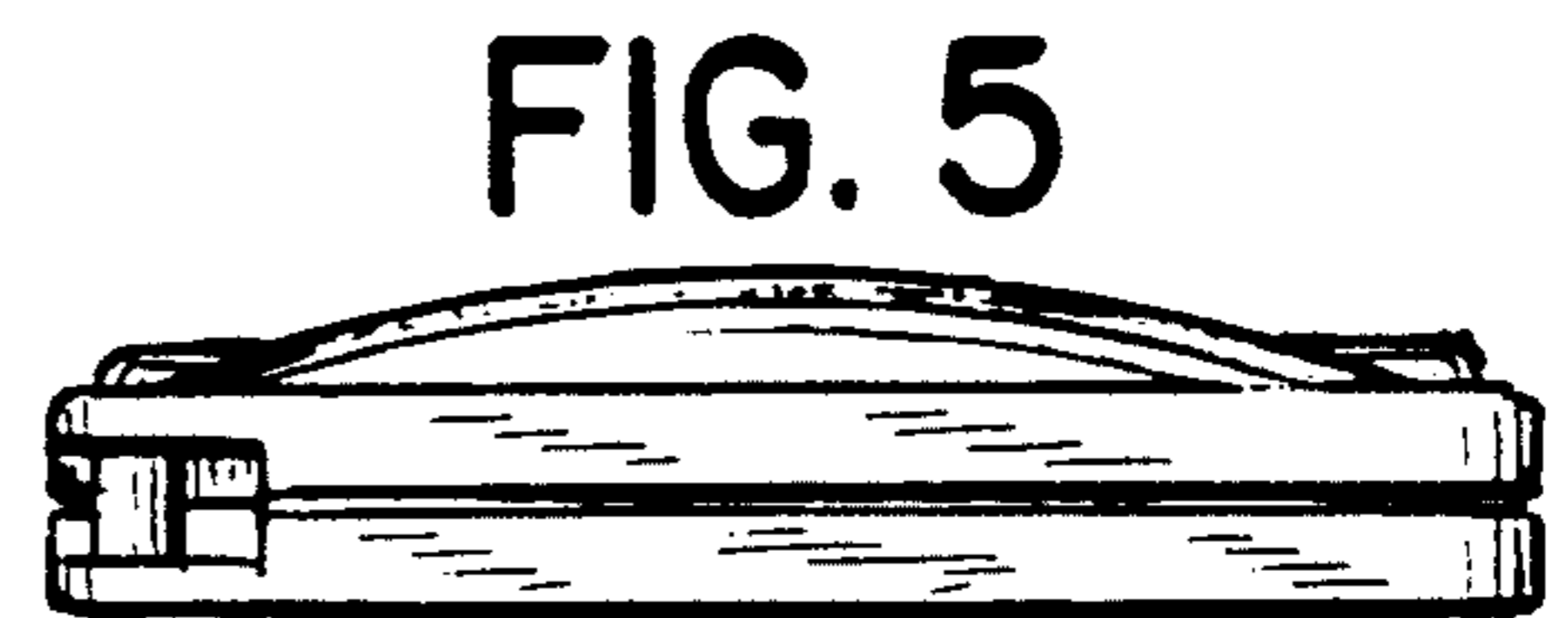
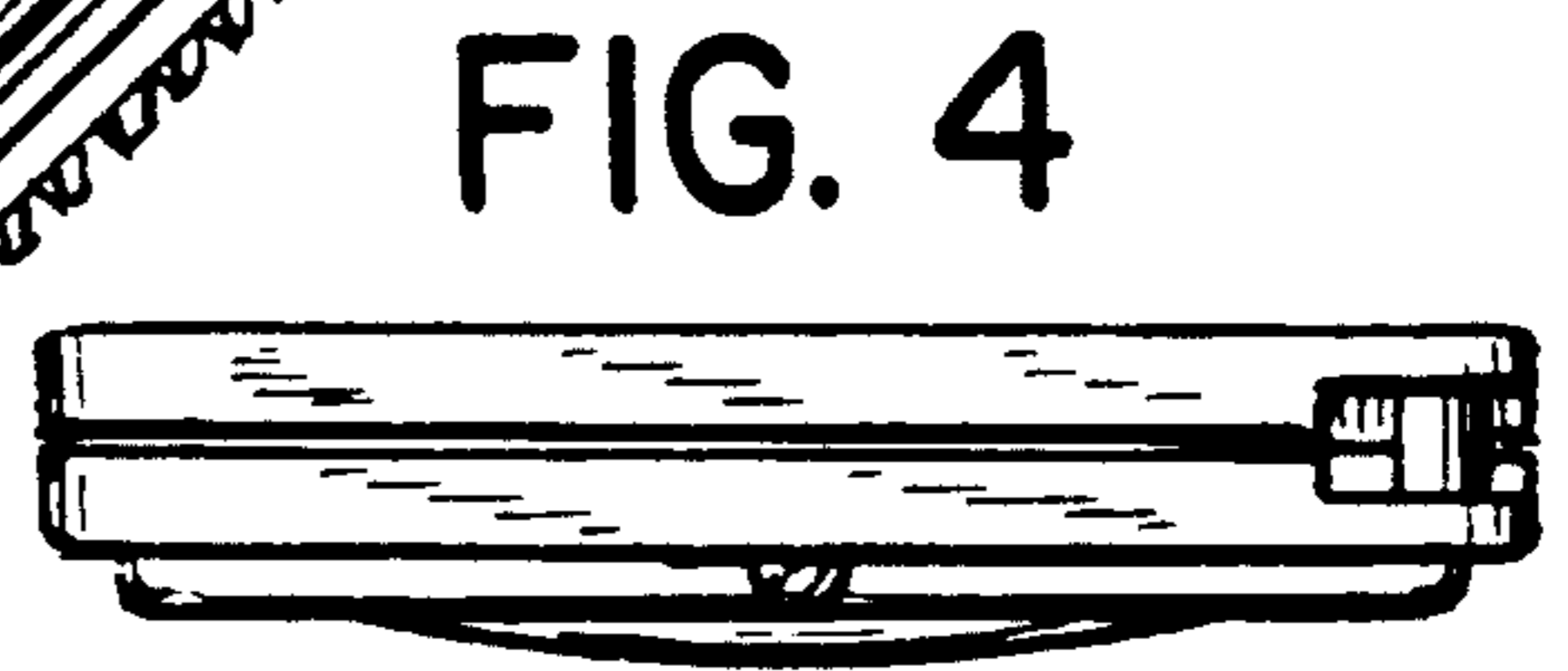
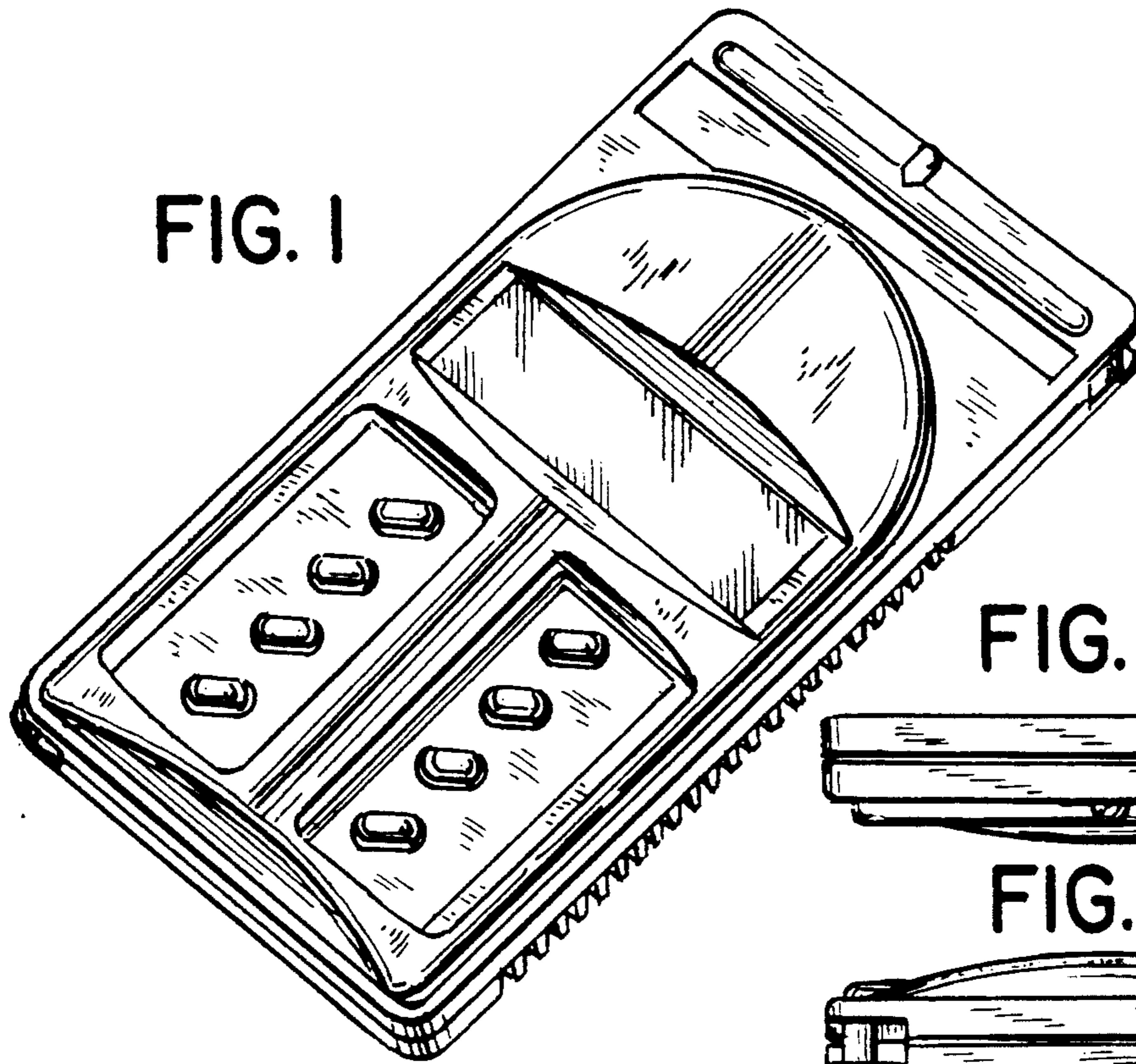

FIG. 2

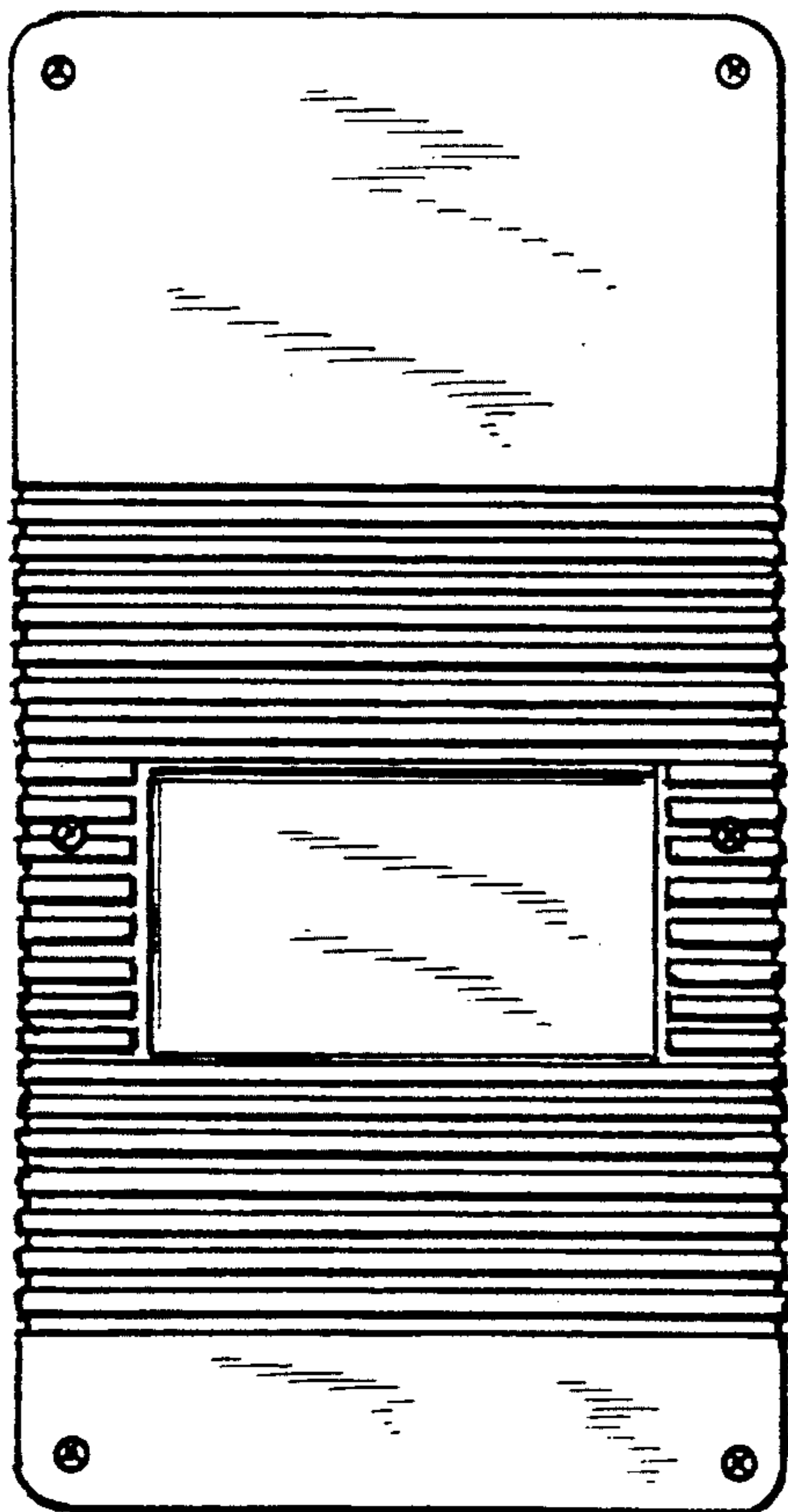

FIG. 3

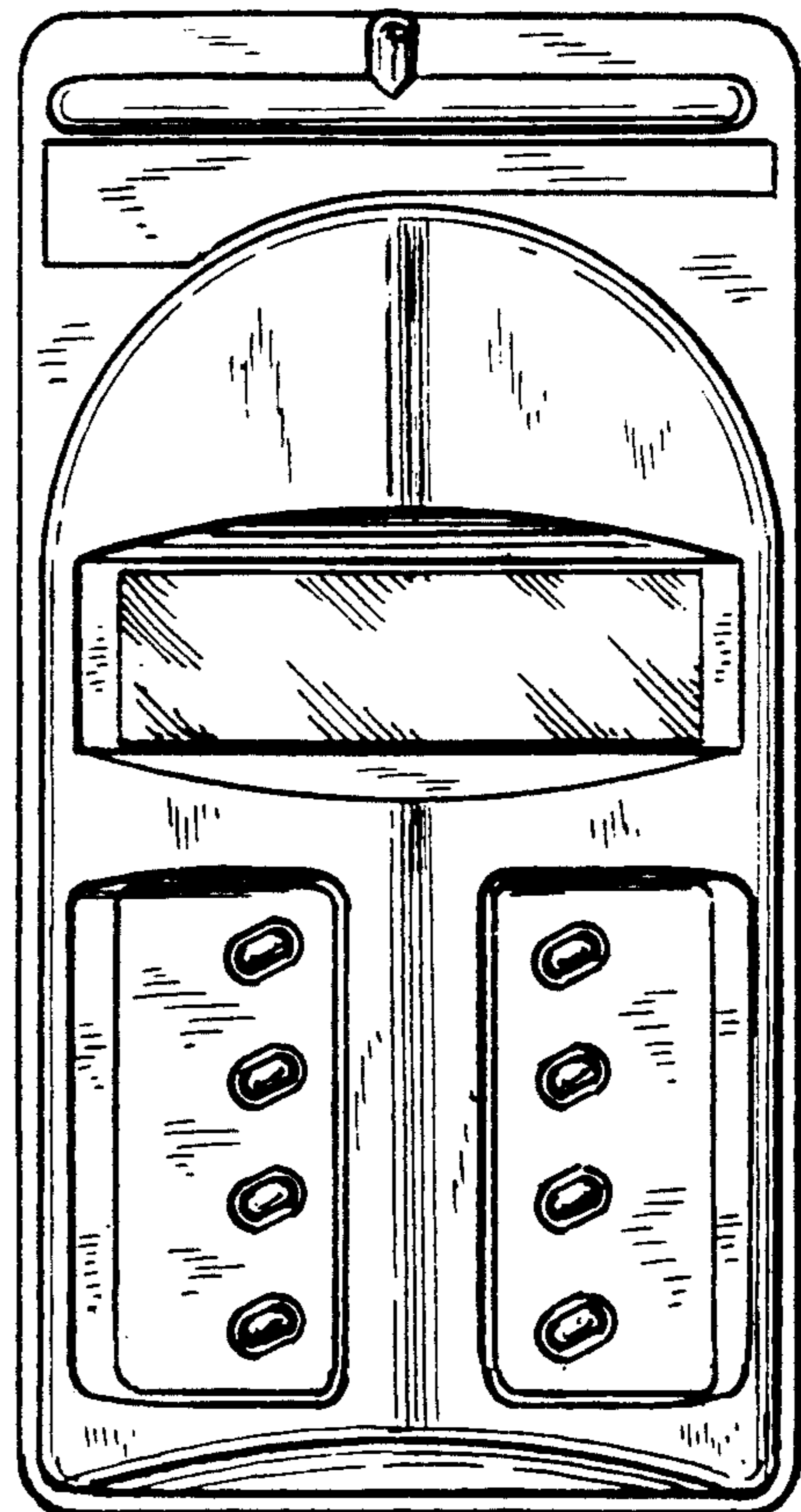

FIG. 6



FIG. 7

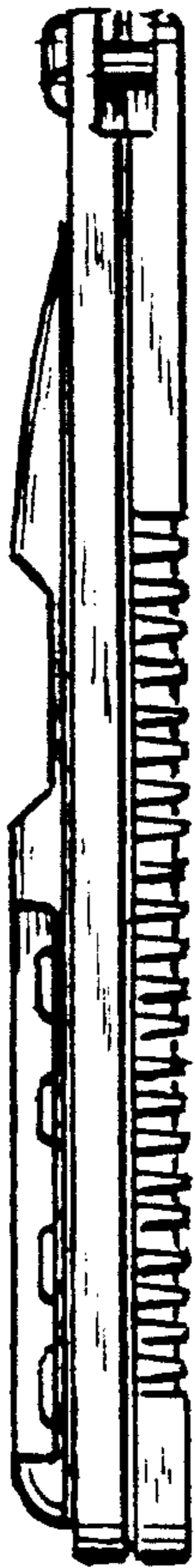

FIG. 13

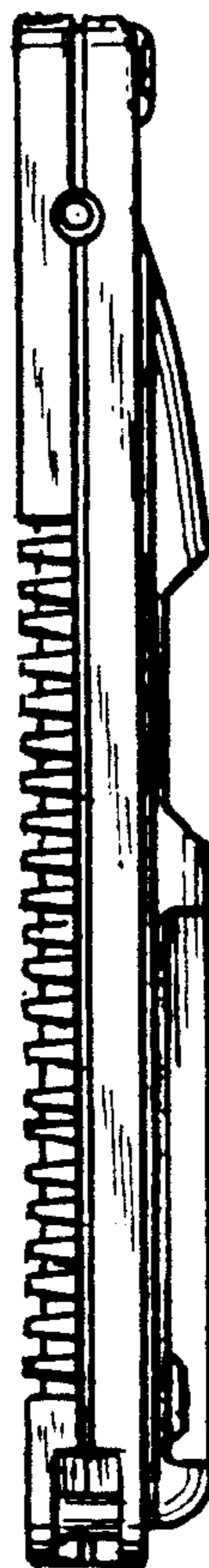

FIG. 14

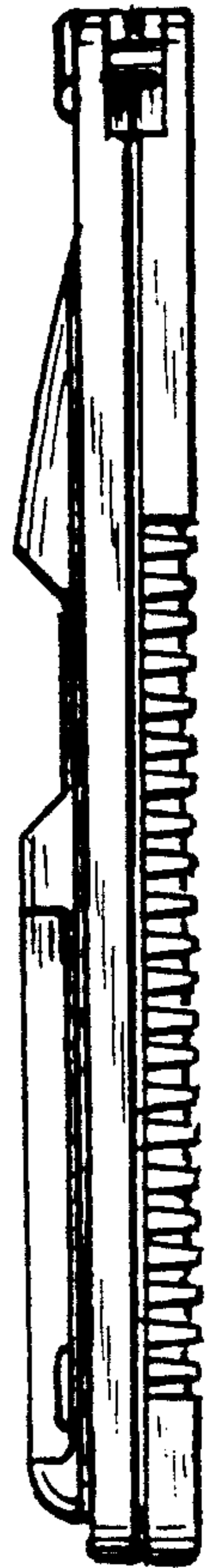

FIG. 8

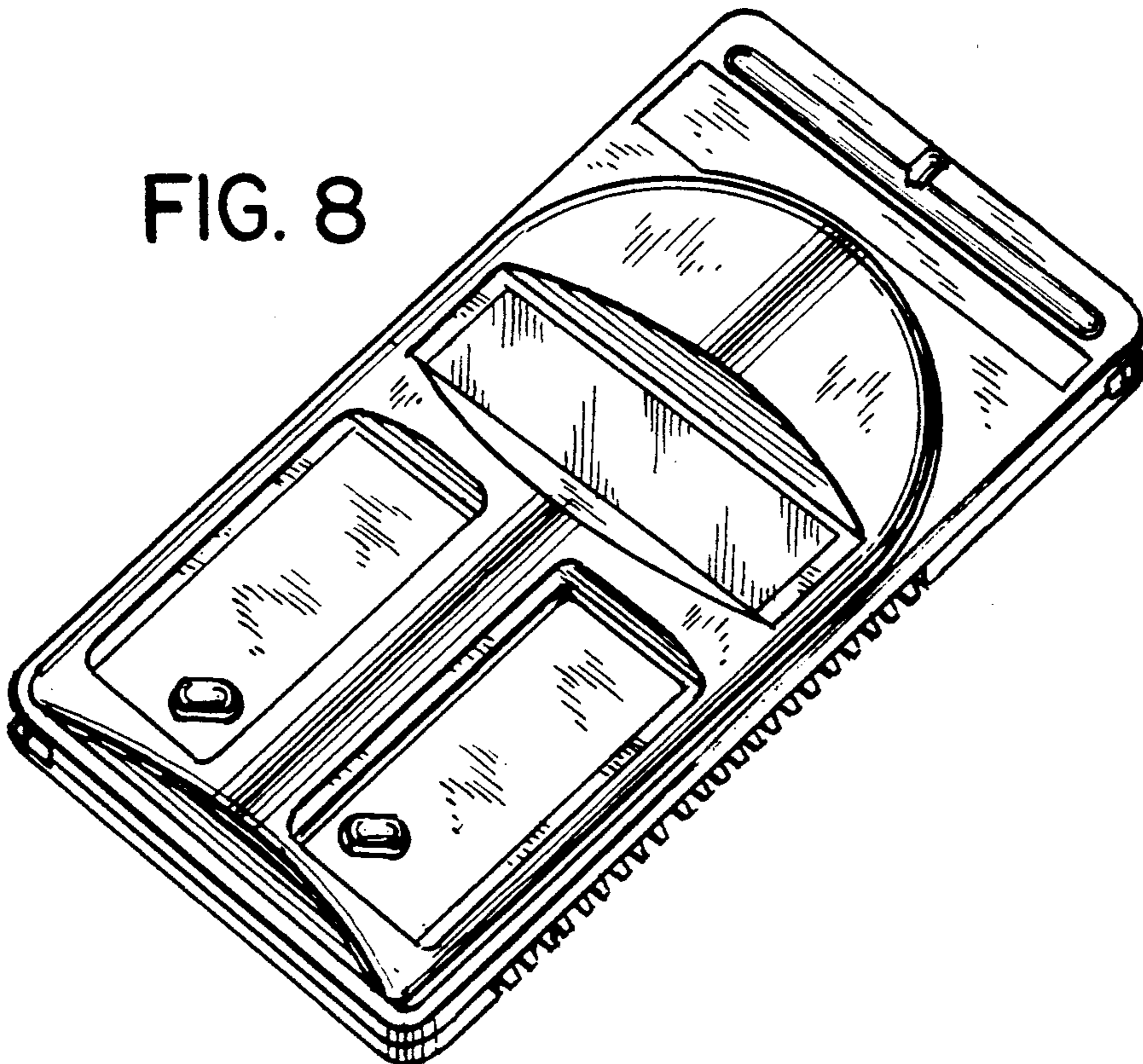

FIG. 9

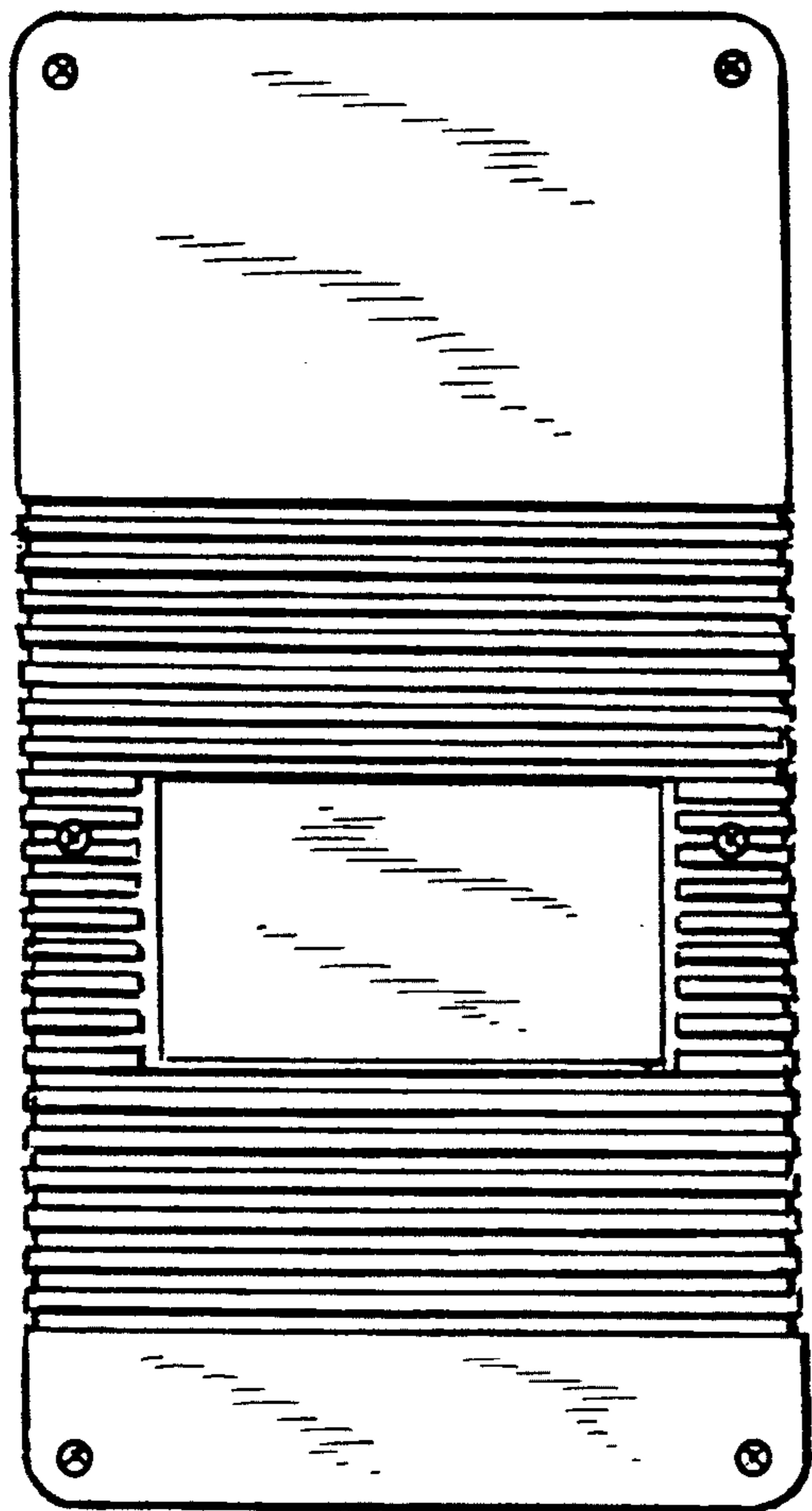

FIG. 10

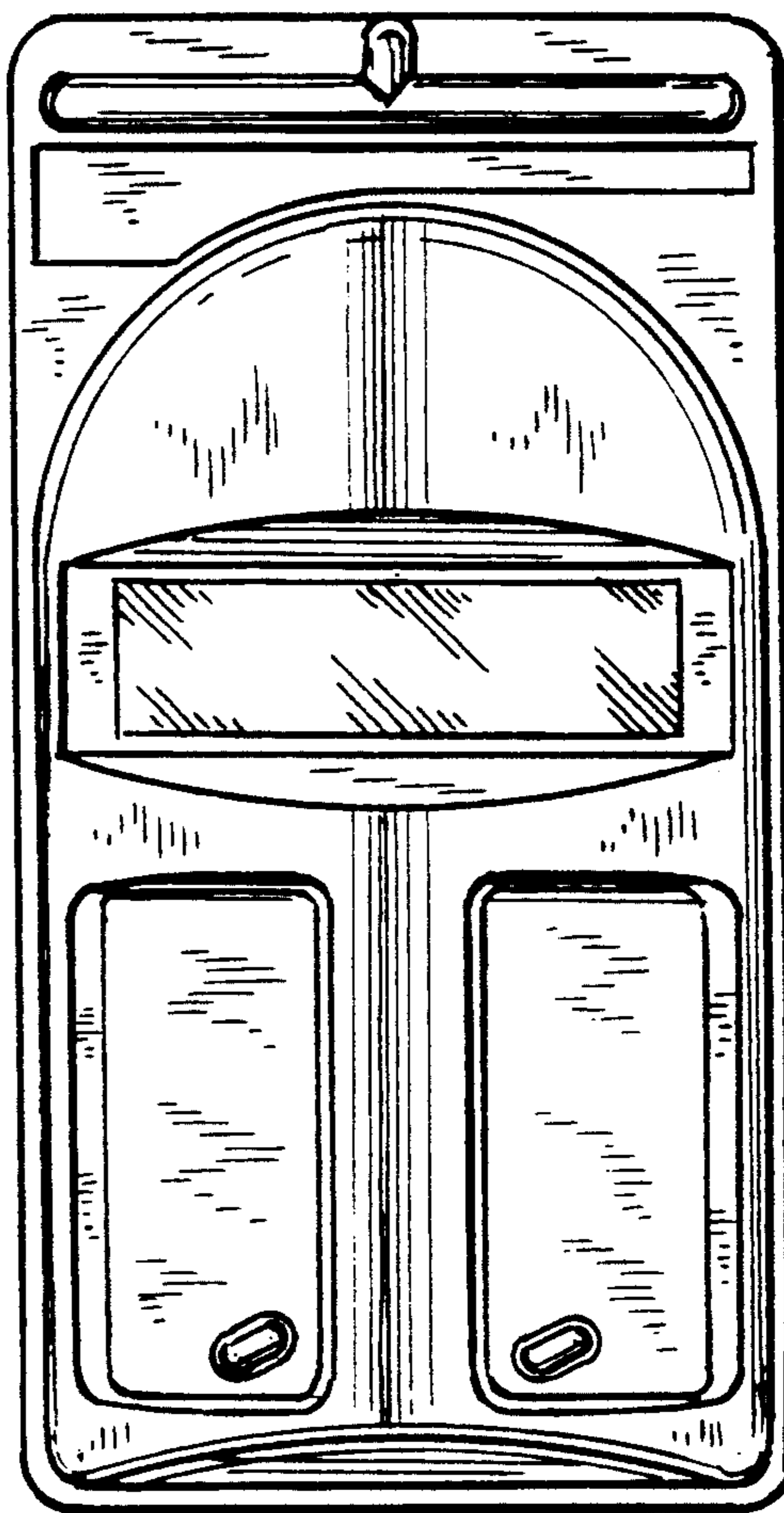

FIG. 11

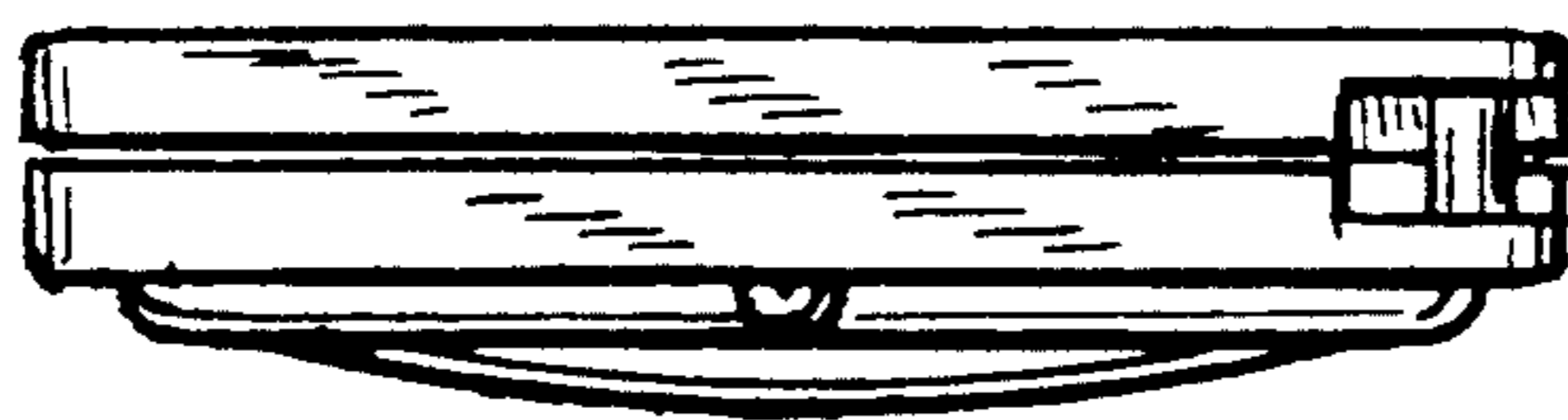

FIG. 12

