



US00D330898S

United States Patent [19]

[11] Patent Number: **Des. 330,898**

Capra

[45] Date of Patent: **** Nov. 10, 1992**

[54] OUTBOARD MOTOR BRACKET

[76] Inventor: **Theodore L. Capra**, 1984 Edgewater Ave., Arden Hills, Minn. 55112

[**] Term: **14 Years**

[21] Appl. No.: **377,916**

[22] Filed: **Jul. 10, 1989**

[52] U.S. Cl. **D15/4; D12/317**

[58] Field of Search **D15/4, 7; 248/640-643, 248/351; 440/900, 56, 61-62, 7; D12/317**

[56] References Cited

U.S. PATENT DOCUMENTS

D. 288,205	2/1987	Bergeron	D12/317
D. 289,296	4/1987	Mahoney	D15/4
D. 297,013	8/1988	McGuire	D15/4
D. 308,850	6/1990	McGuire	D15/4

Primary Examiner—A. Hugo Word

Assistant Examiner—R. Seifers
Attorney, Agent, or Firm—Merchant, Gould, Smith,
Edell, Welter & Schmidt

[57] CLAIM

The ornamental design for an outboard motor bracket, as shown and described.

DESCRIPTION

FIG. 1 is an exploded perspective view of an outboard motor bracket showing my new design; FIG. 2 is a top plan view; FIG. 3 is a side elevational view, the opposite side being a mirror image; FIG. 4 is a bottom plan view; and, FIG. 5 is an end elevational view, the opposite side being a mirror image. The broken line showing of a boat motor is for illustrative purposes only and forms no part of the claimed design.

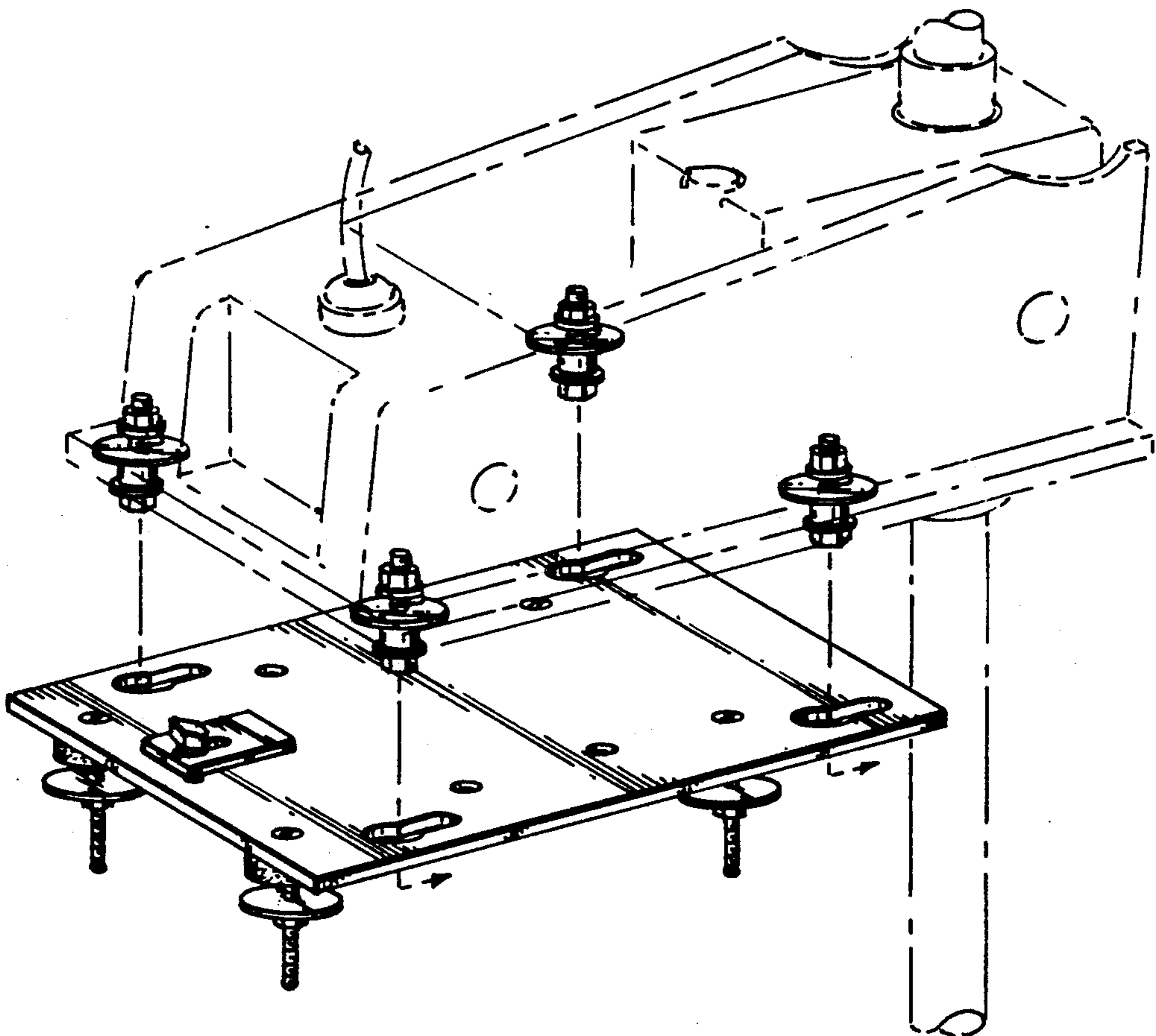

FIG. 1

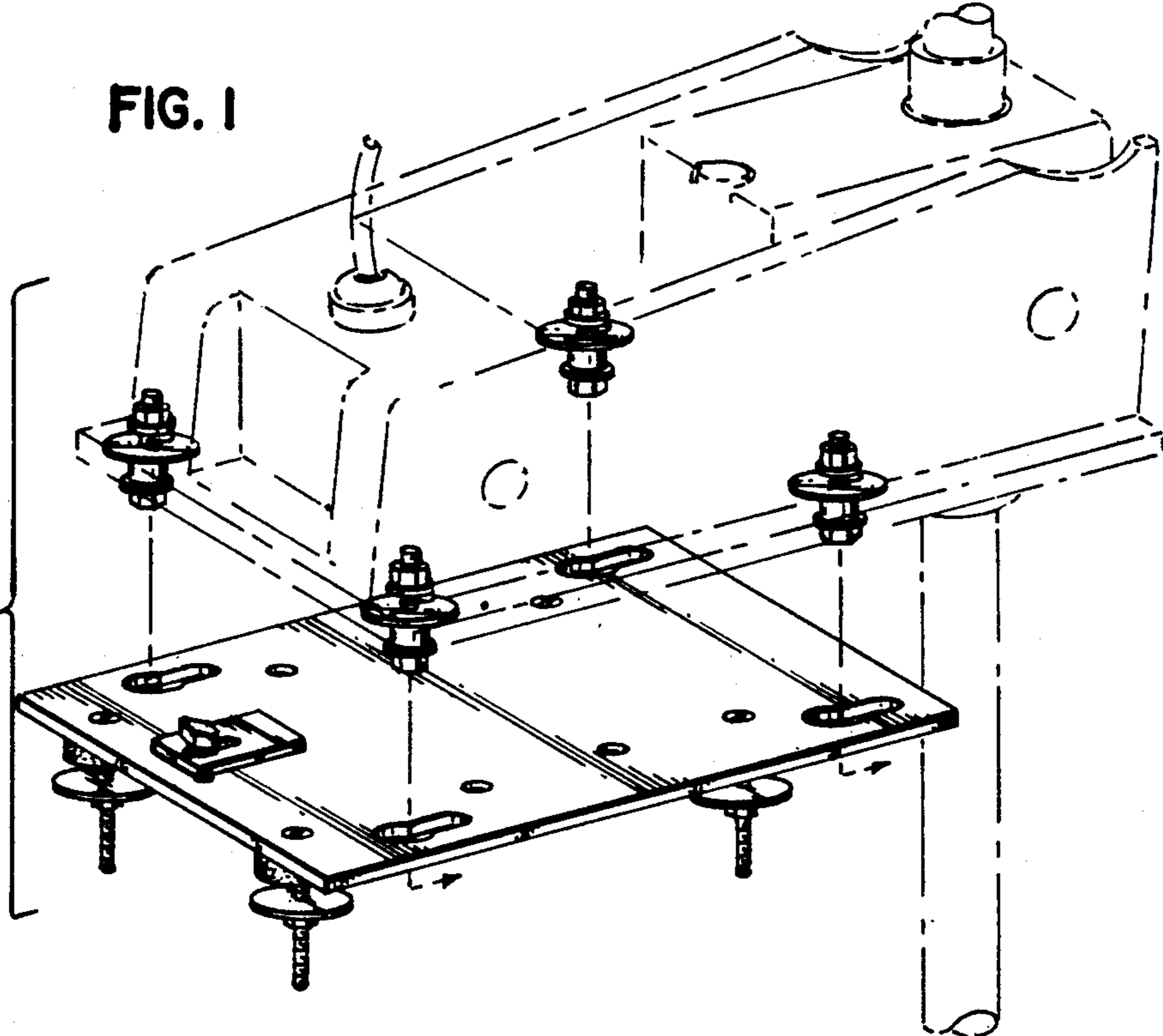

FIG. 2

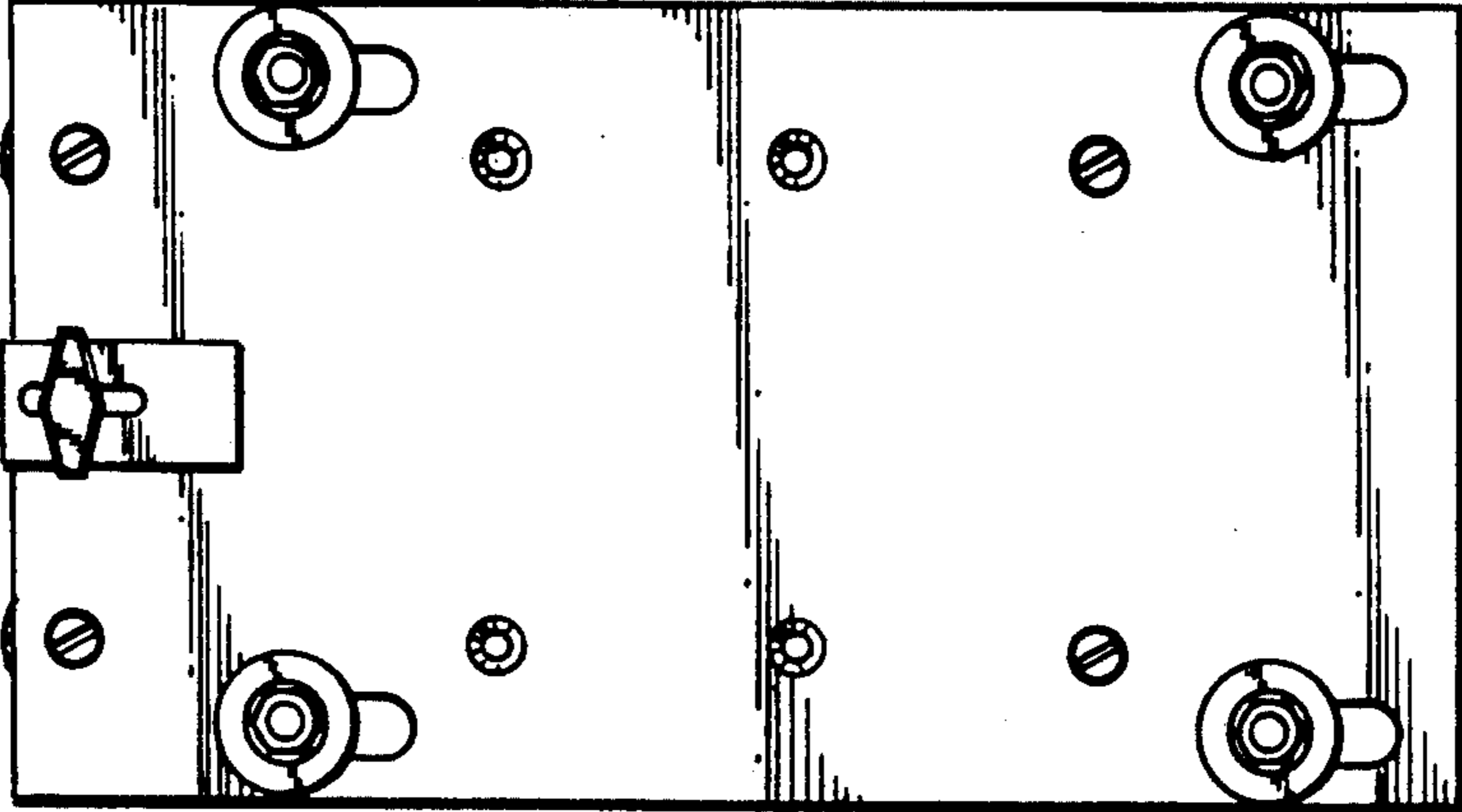

FIG. 3

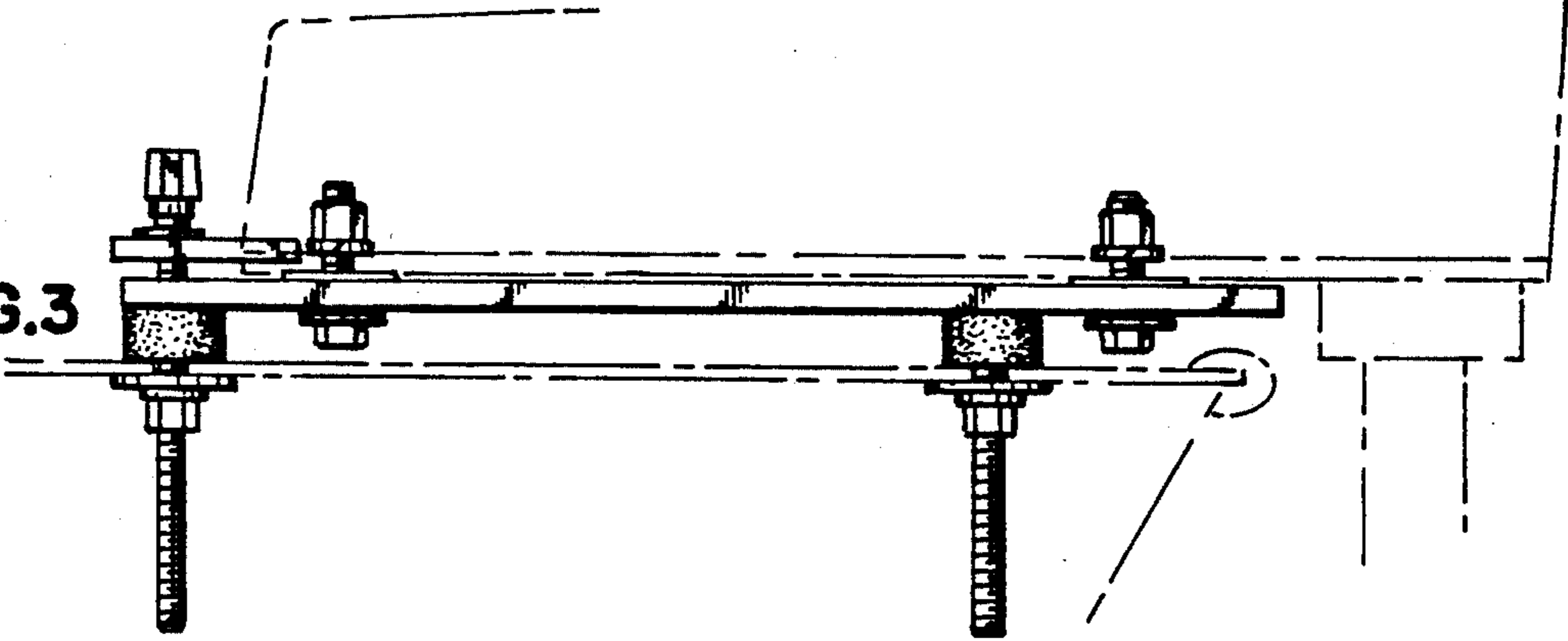

FIG. 4

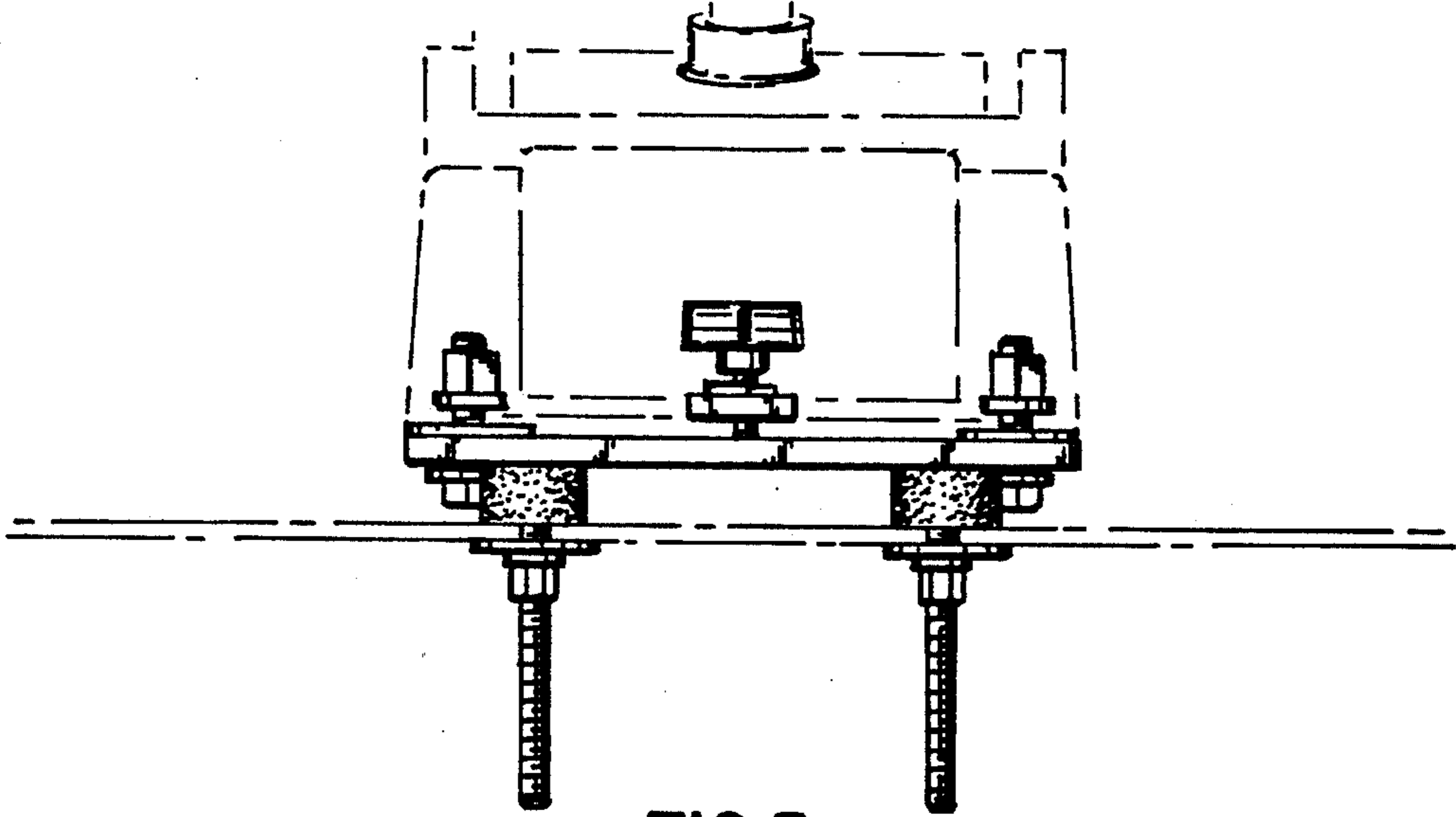
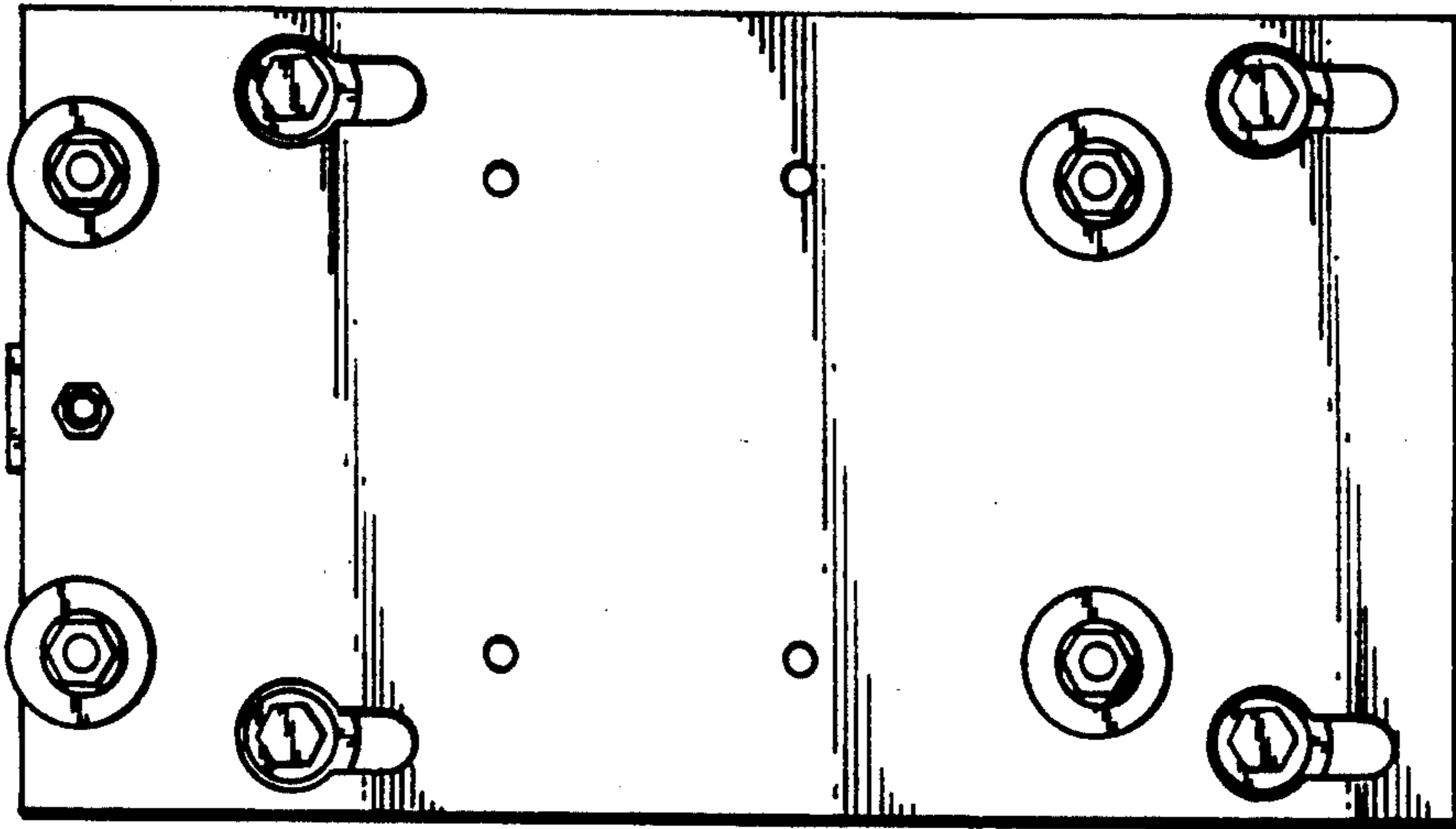

FIG. 5