



US00D330897S

United States Patent [19]

[11] Patent Number: **Des. 330,897**

Carlson et al.

[45] Date of Patent: **** Nov. 10, 1992**

[54] **INTERNAL COMBUSTION ENGINE**

[75] Inventors: **Robert B. Carlson**, Bloomington;
Darrell W. Hinklin, Excelsior, both
of Minn.

[73] Assignee: **The Toro Company**, Minneapolis,
Minn.

[**] Term: **14 Years**

[21] Appl. No.: **616,292**

[22] Filed: **Nov. 19, 1990**

[52] U.S. Cl. **D15/1; D15/3**

[58] Field of Search **D15/1, 3; 123/50 A,
123/50 B, 50 R, 51 R, 51 A, 51 B, 65 R, 70 R,
51 BD, 65 P, 65 PD, 65 PE**

Form No. MP9431, no copyright noted but believed to be a 1988 publication.

Toro leaflet entitled "OHV 4-Cycle Engines", Form No. 490-4881-C, copyright 1985.

Lawn-Boy leaflet entitled "The Most Important Oil Change in Mower History", Form No. 215715, copyright 1989.

Honda leaflet entitled "Honda Engines", Form No. C0800, copyright 1988.

Primary Examiner—A. Hugo Word

Assistant Examiner—R. Seifert

Attorney, Agent, or Firm—Donald S. Trevarthen

[57] **CLAIM**

The ornamental design for an internal combustion engine, as shown.

[56] **References Cited**

U.S. PATENT DOCUMENTS

D. 305,432	1/1990	Hashigaki	D15/1
D. 307,147	4/1990	Sasaki et al.	D15/1
D. 309,457	7/1990	Eifert et al.	D15/1
D. 309,458	7/1990	Johnson et al.	D15/1

OTHER PUBLICATIONS

Vanguard leaflet entitled "The Vanguard Engines",

DESCRIPTION

FIG. 1 is a front perspective of an internal combustion engine showing our new design;

FIG. 2 is a top plan view thereof, the bottom plan view being plain and unornamented;

FIG. 3 is a left side elevational view thereof;

FIG. 4 is a front elevational view thereof;

FIG. 5 is a right side elevational view thereof; and,

FIG. 6 is a rear elevational view thereof.

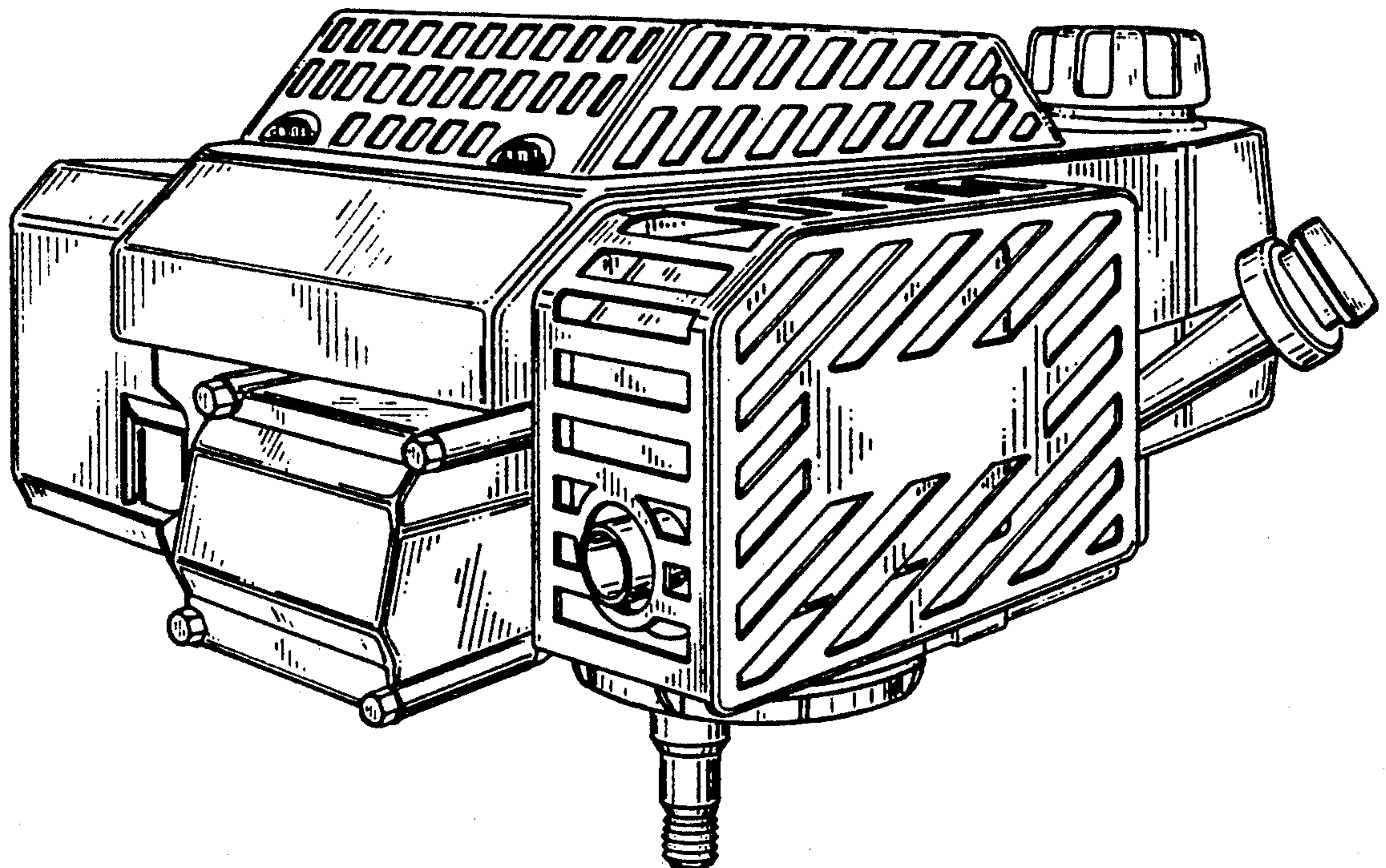

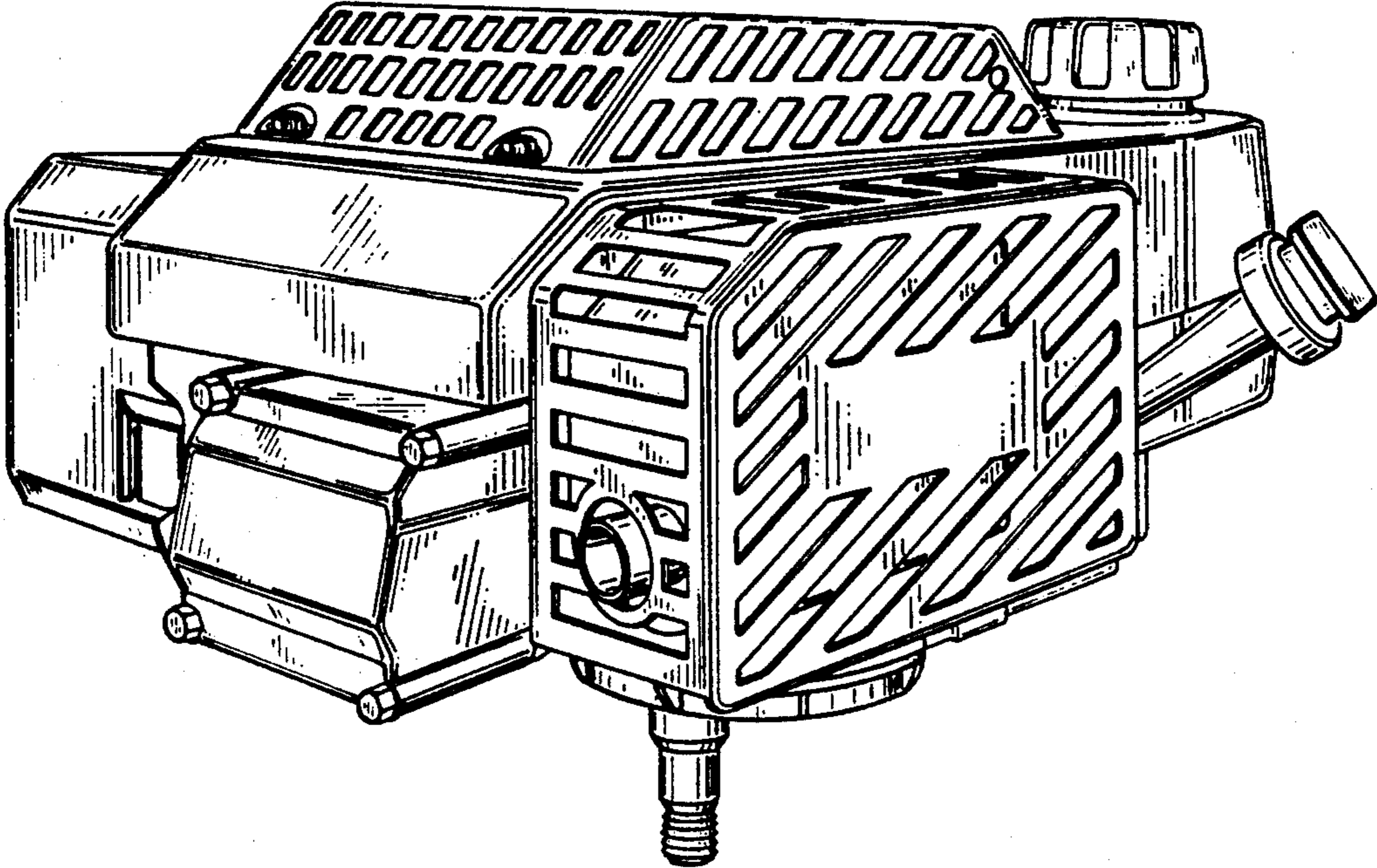

Fig. 1

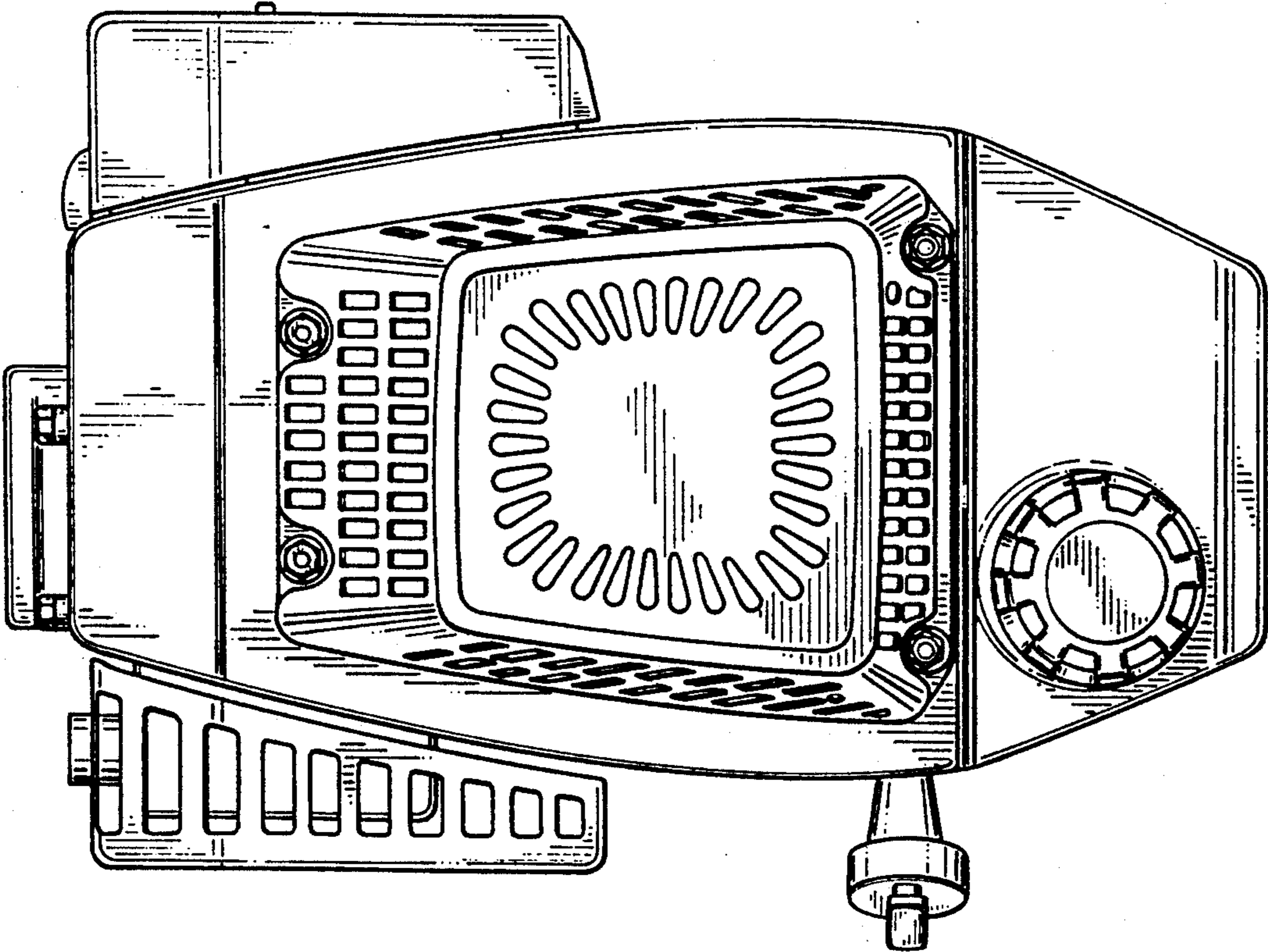

Fig. 2

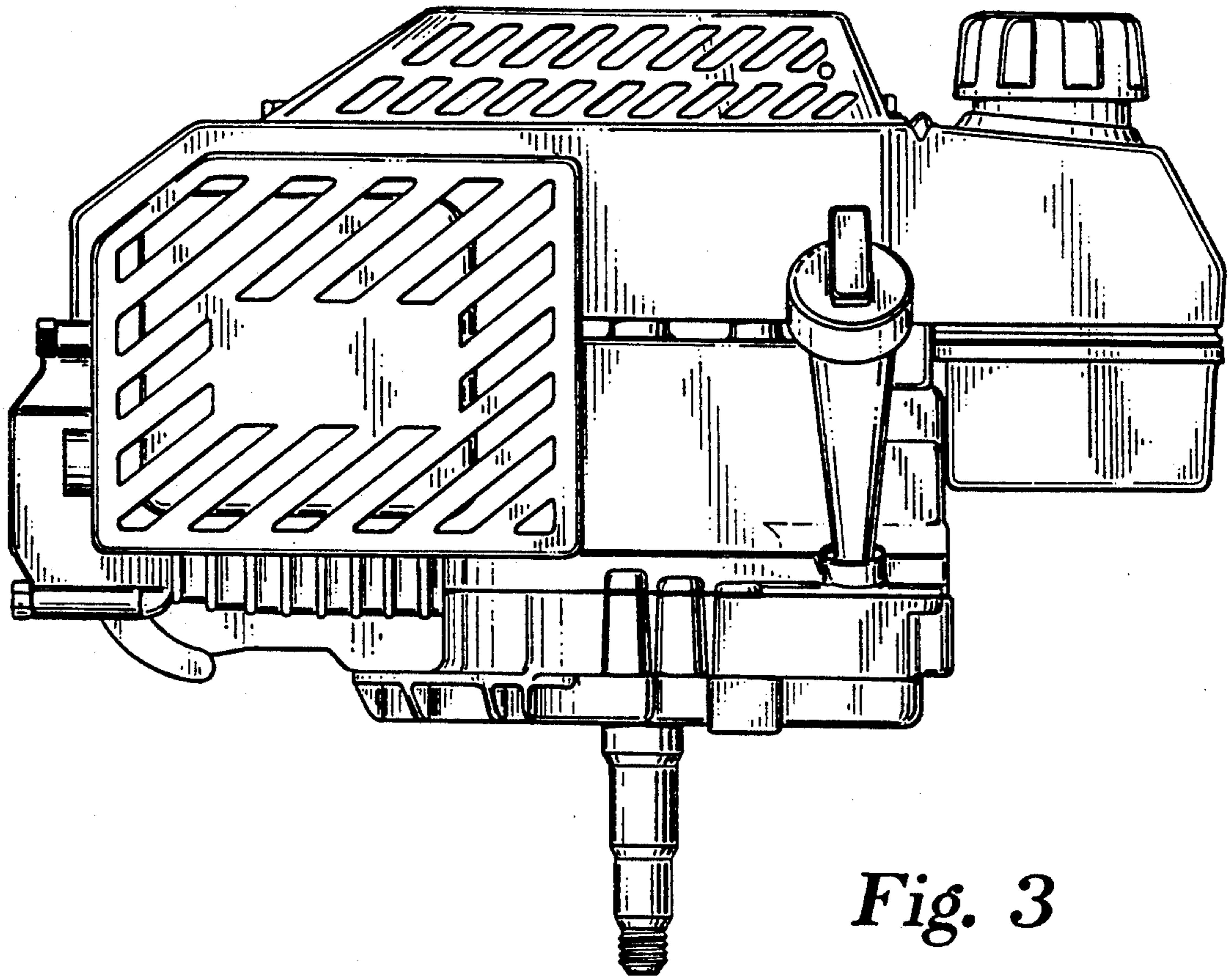

Fig. 3

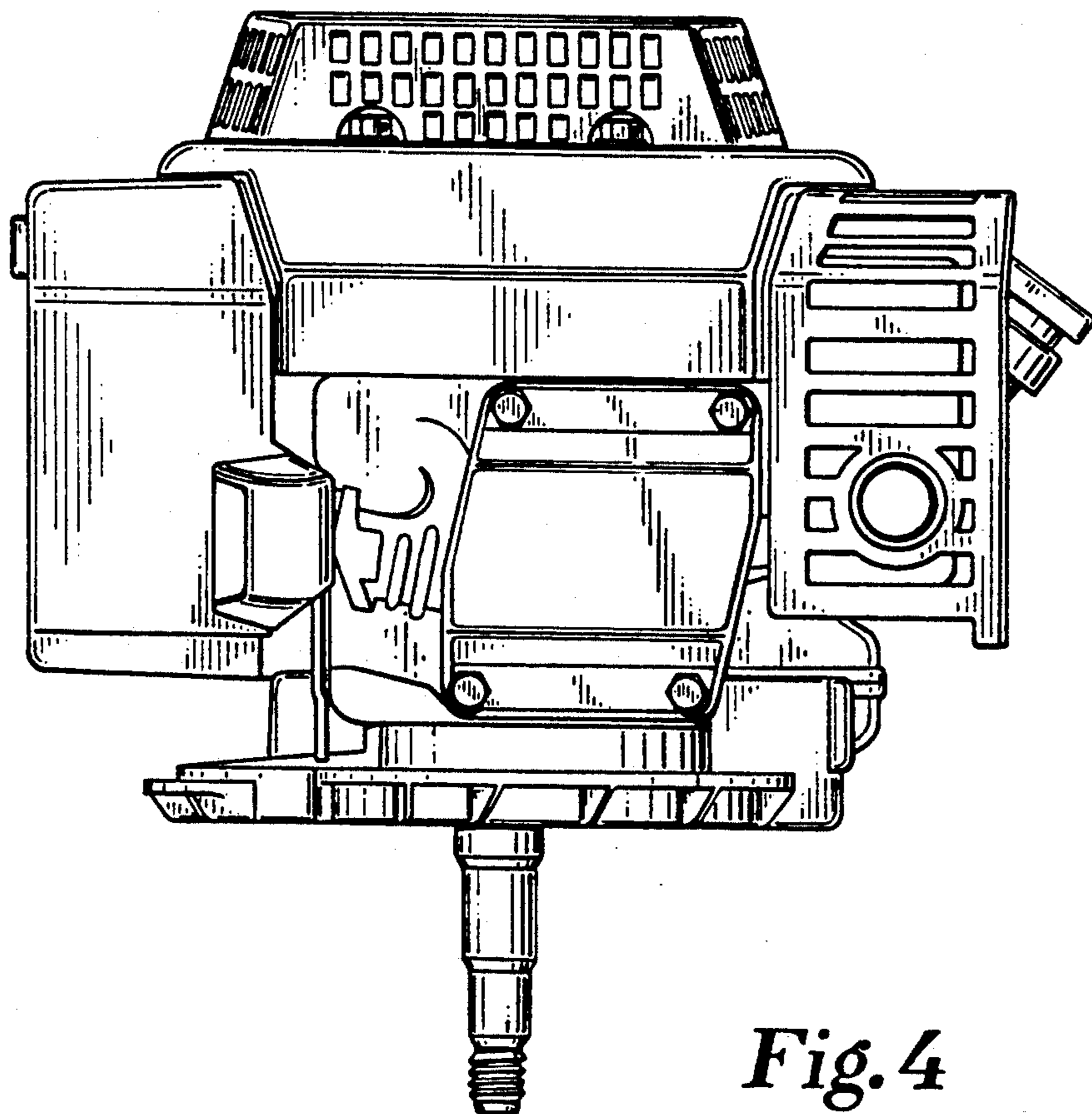

Fig. 4

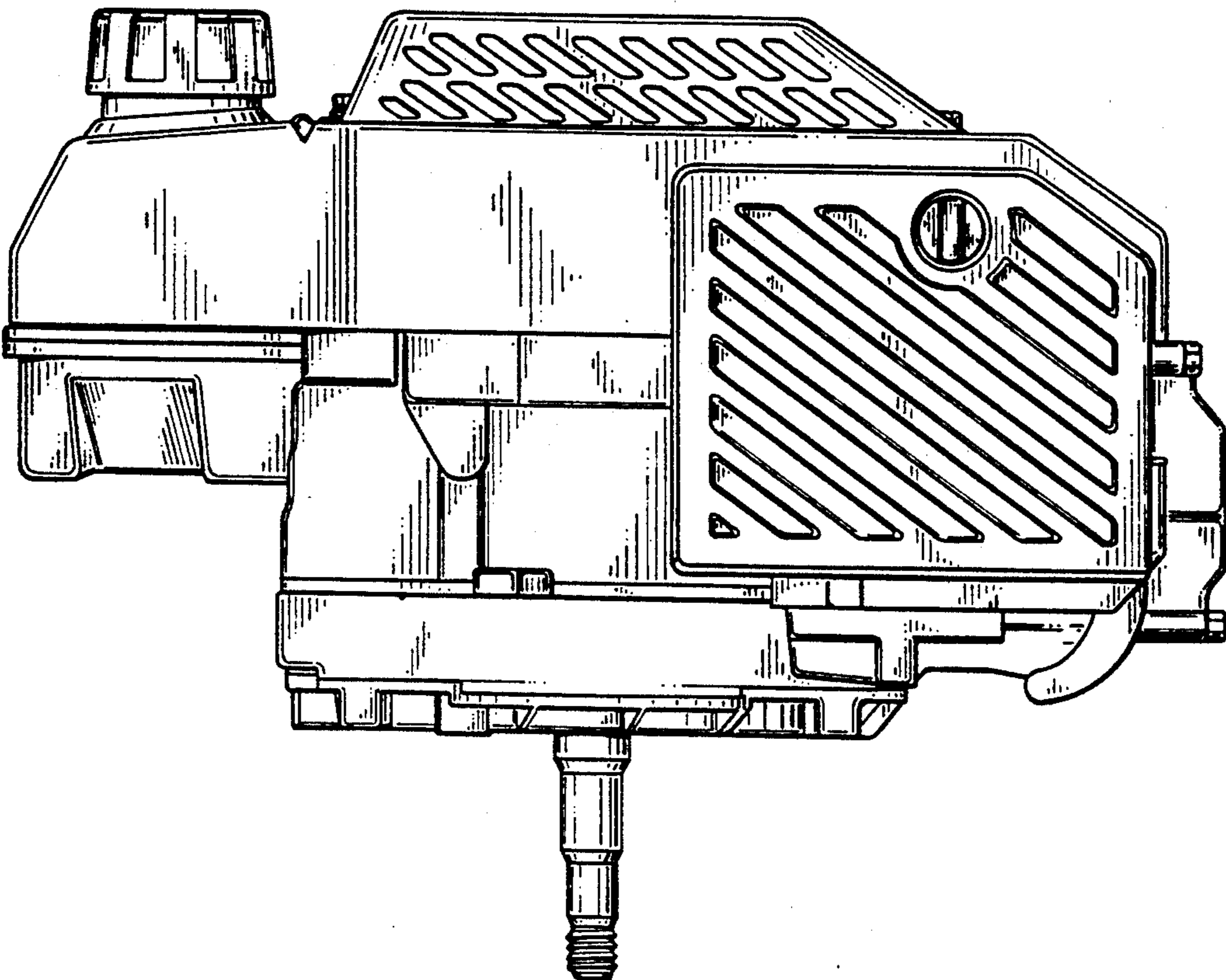

Fig. 5

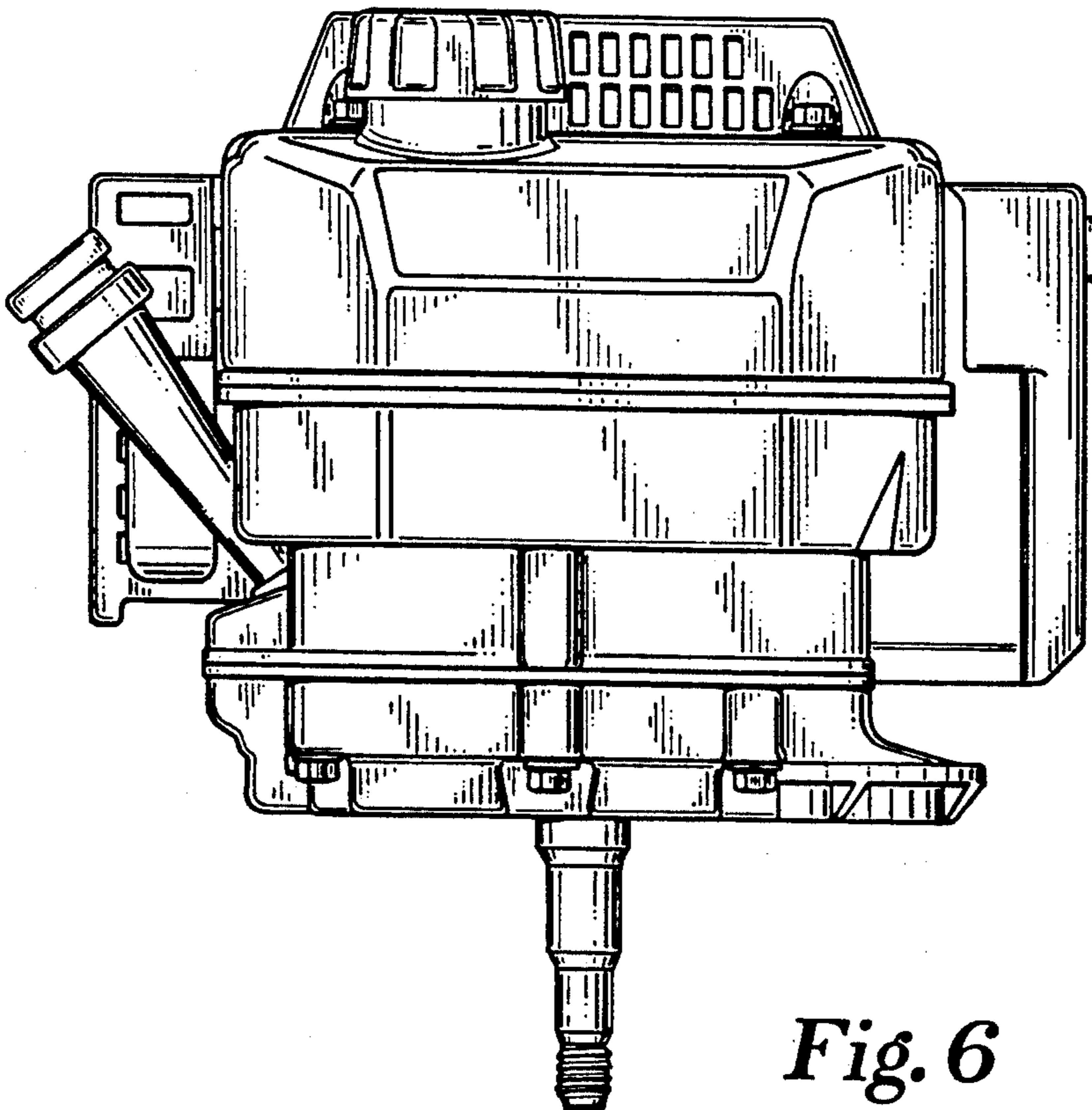

Fig. 6