



US00D330892S

# United States Patent [19]

[11] Patent Number: **Des. 330,892**

Hassel et al.

[45] Date of Patent: **\*\* Nov. 10, 1992**

## [54] COMPARTMENTED KEYBOARD DRAWER

[75] Inventors: **H. Charles Hassel, Los Angeles;**  
**Alan W. B. Nash, Northridge, both of Calif.**

[73] Assignee: **MicroComputer Accessories, Inc.,**  
**Los Angeles, Calif.**

[\*\*] Term: **14 Years**

[21] Appl. No.: **685,012**

[22] Filed: **Apr. 15, 1991**

[52] U.S. Cl. .... **D14/114**

[58] Field of Search ..... **D14/114; D6/449, 429-431,**  
**D6/474, 509-510; 340/700; 312/196, 322;**  
**D18/55, 52, 53; 248/917-924, 678, 676**

### [56] References Cited

#### U.S. PATENT DOCUMENTS

D. 279,441	7/1985	Fudala et al. ....	D6/436 X
D. 285,270	8/1986	Hannah et al. ....	D6/430 X
D. 287,678	1/1987	Hatcher et al. ....	D14/114 X
D. 302,425	7/1989	LaBudde et al. ....	D14/114
D. 316,710	5/1991	Drake et al. ....	D14/114
4,657,214	4/1987	Foster .....	D14/114 X

### OTHER PUBLICATIONS

Bell Atlantic Business Supplies item keyboard platform, p. 62, 1988.

*Primary Examiner*—Susan J. Lucas

*Assistant Examiner*—M. H. Tung

### [57] CLAIM

The ornamental design for a compartmented keyboard drawer, as shown and described.

### DESCRIPTION

FIG. 1 is a perspective view of a compartmented keyboard drawer showing our new design, the broken line drawing of a computer stand is for illustrative purposes only and forms no part of the claimed design;

FIG. 2 is a perspective view thereof, the side shelf shown in an "out" position;

FIG. 3 is a perspective view thereof, the utility compartment shown in an "open" position;

FIG. 4 is a top plan view thereof;

FIG. 5 is a front elevational view thereof;

FIG. 6 is a left side elevational view thereof, the right side being a mirror image; and,

FIG. 7 is a rear elevational view thereof.

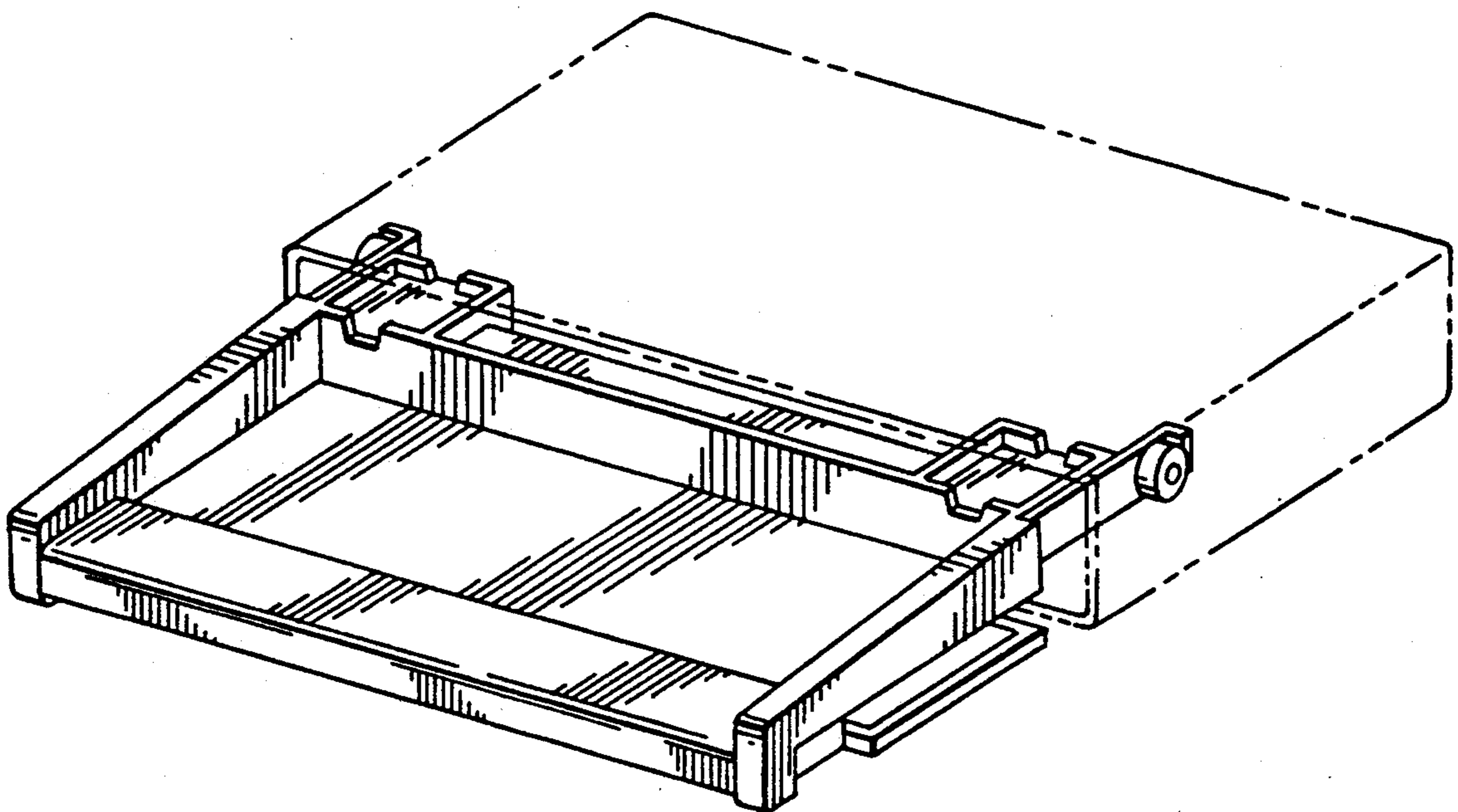

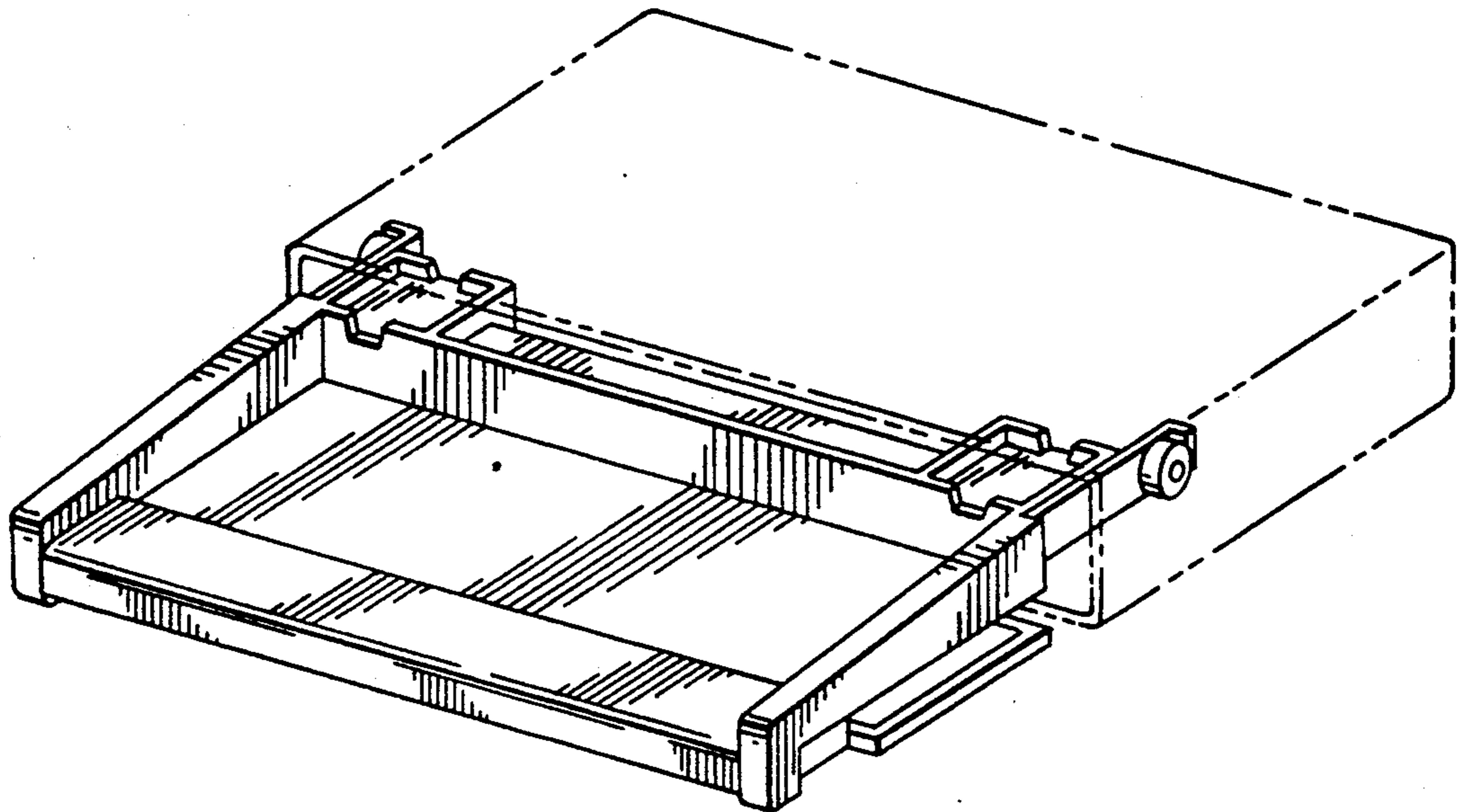

*FIG. 1*

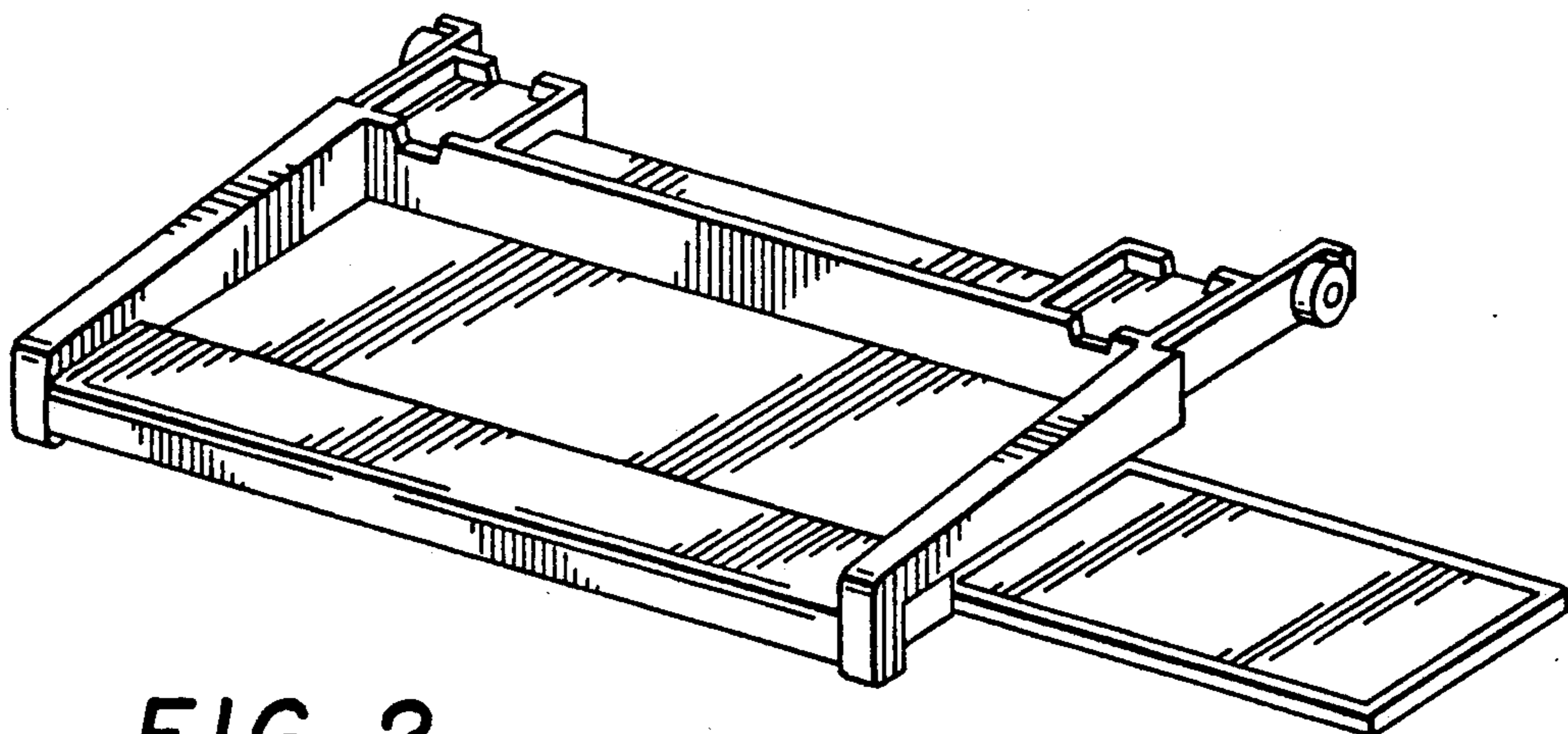

*FIG. 2*

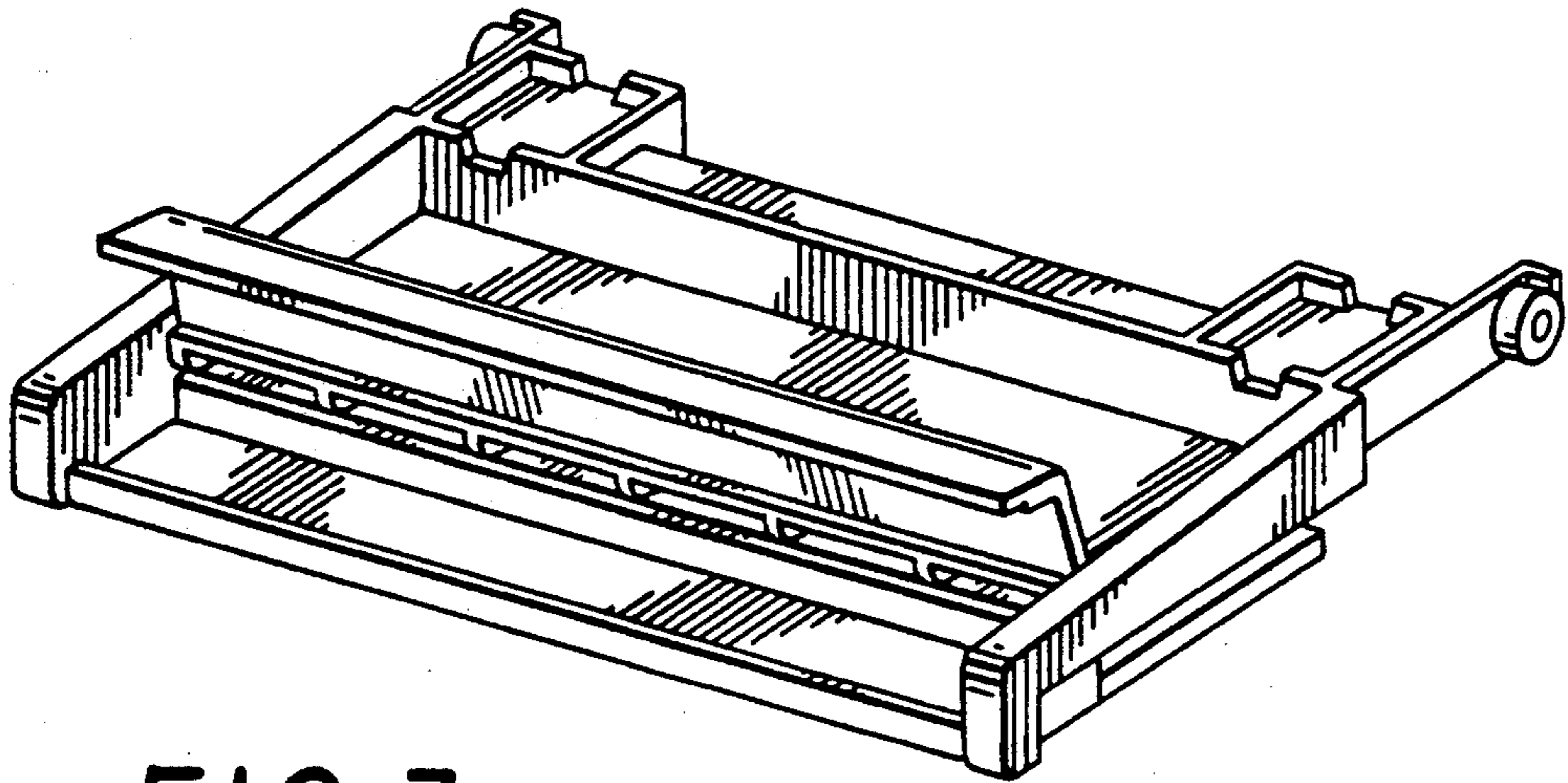

FIG. 3

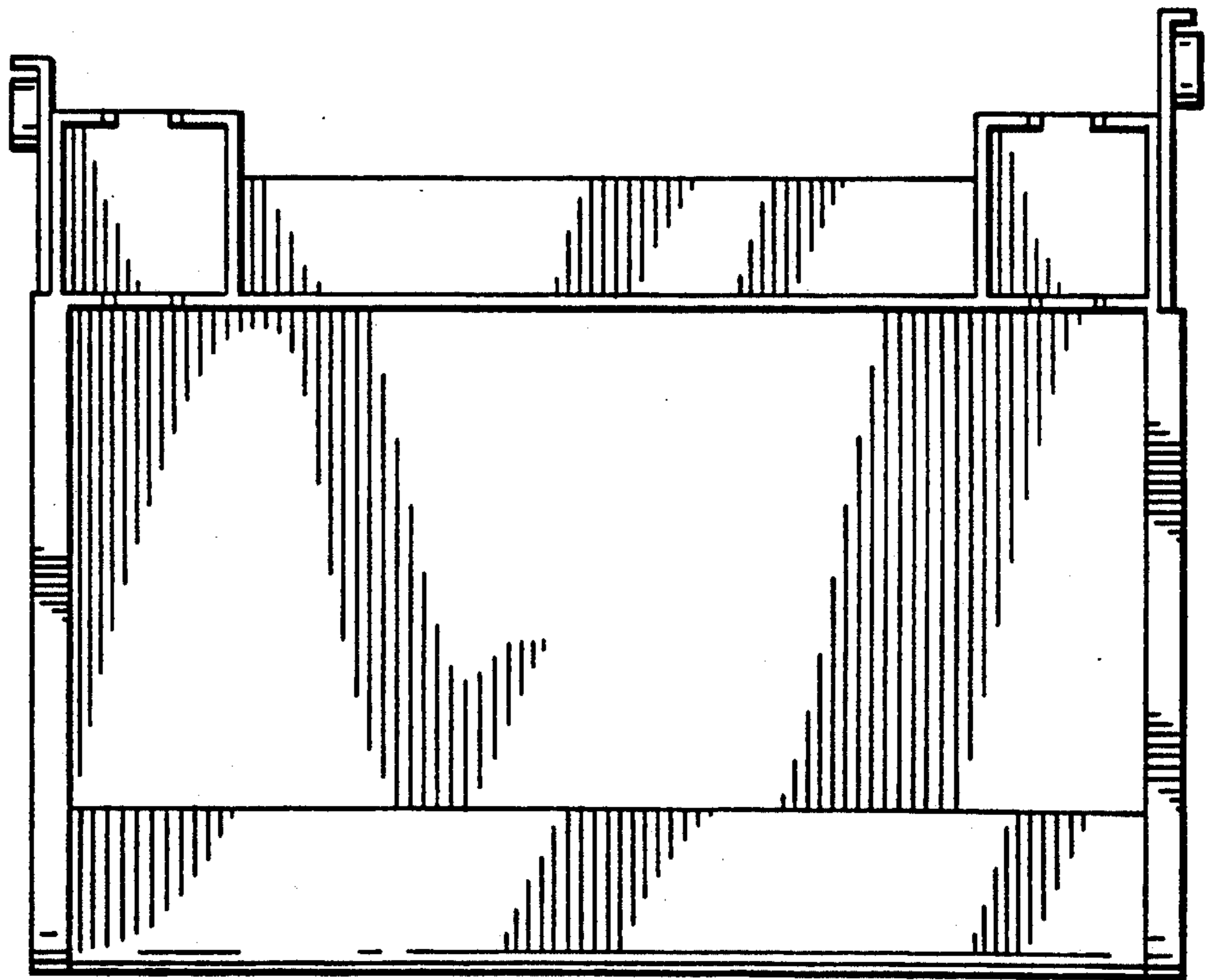
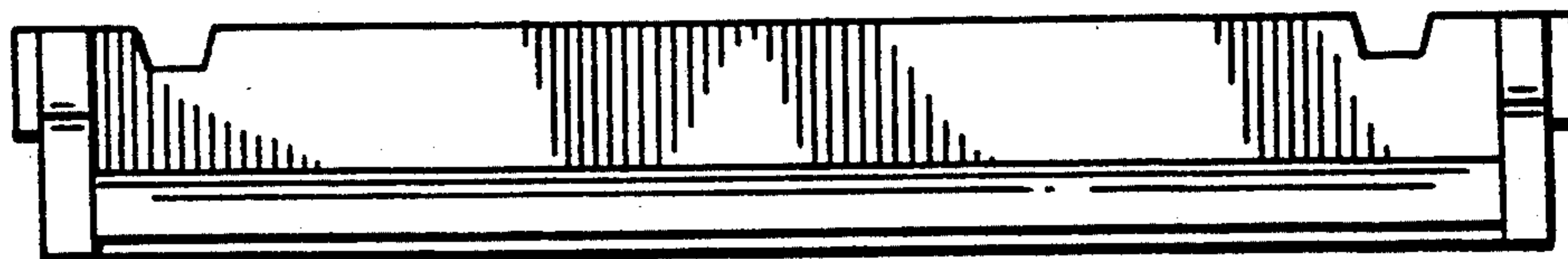
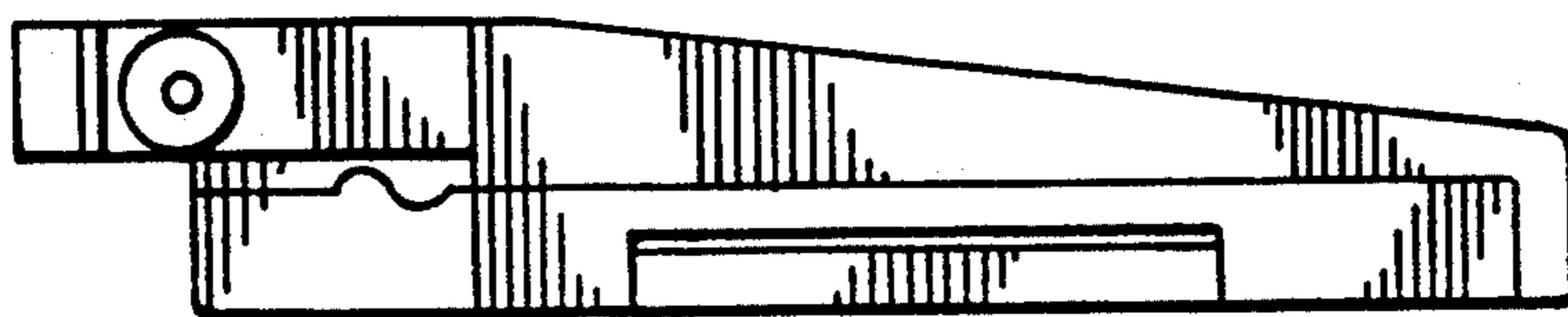

FIG. 4



**FIG. 5**



**FIG. 6**

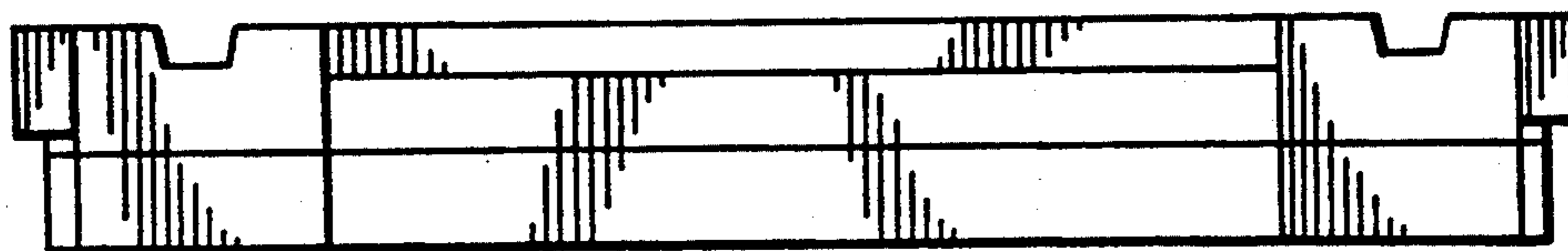

**FIG. 7**