



US00D330880S

United States Patent [19]

Lively

[11] Patent Number: **Des. 330,880**

[45] Date of Patent: **** Nov. 10, 1992**

[54] **BUMPER UNIT**

[76] Inventor: **Thomas J. Lively, 676 - 20th Ave., Yuma, Ariz. 85364**

[**] Term: **14 Years**

[21] Appl. No.: **574,947**

[22] Filed: **Aug. 30, 1990**

[52] U.S. Cl. **D12/169**

[58] Field of Search **D12/169; 293/30, 102, 293/118, 134, 135, 137**

[56] **References Cited**

U.S. PATENT DOCUMENTS

1,925,461	9/1933	Ridge	293/137
3,433,520	3/1969	Kearns et al.	293/137
3,677,595	7/1972	Hamilton	293/118

3,756,643	9/1973	Weed	293/137
4,679,837	7/1987	Bayer et al.	293/102

Primary Examiner—James M. Gandy
Attorney, Agent, or Firm—Leon Gilden

[57] **CLAIM**

The ornamental design for a bumper unit, as shown.

DESCRIPTION

FIG. 1 is a front elevational view of the bumper unit showing my new design;
FIG. 2 is a rear elevational view thereof;
FIG. 3 is an enlarged left side elevational view thereof;
FIG. 4 is an enlarged right side elevational view thereof;
FIG. 5 is a top plan view thereof; and,
FIG. 6 is a bottom plan view thereof.

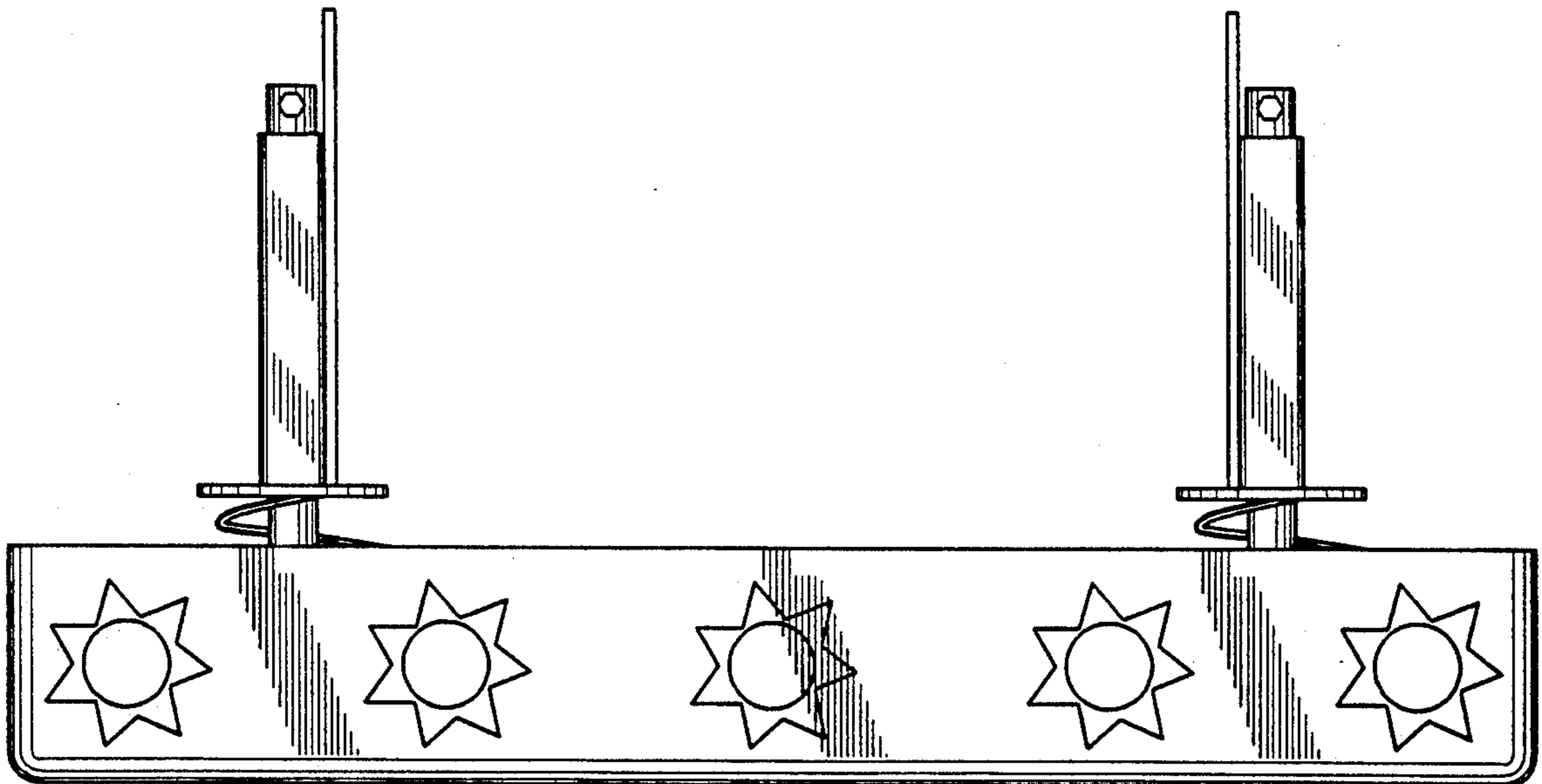

FIG. 1

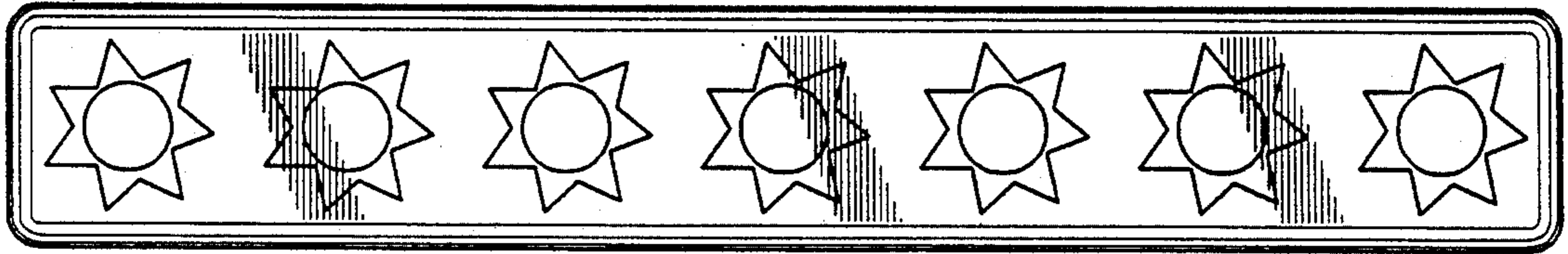

FIG. 2

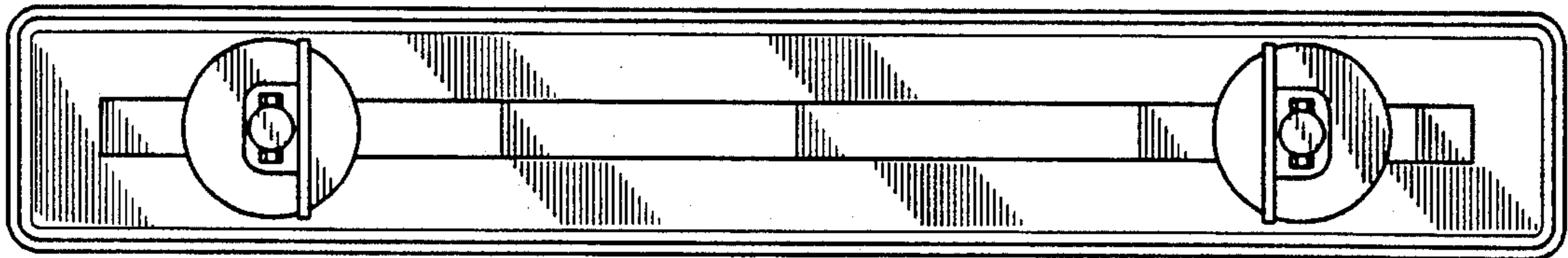

FIG. 3

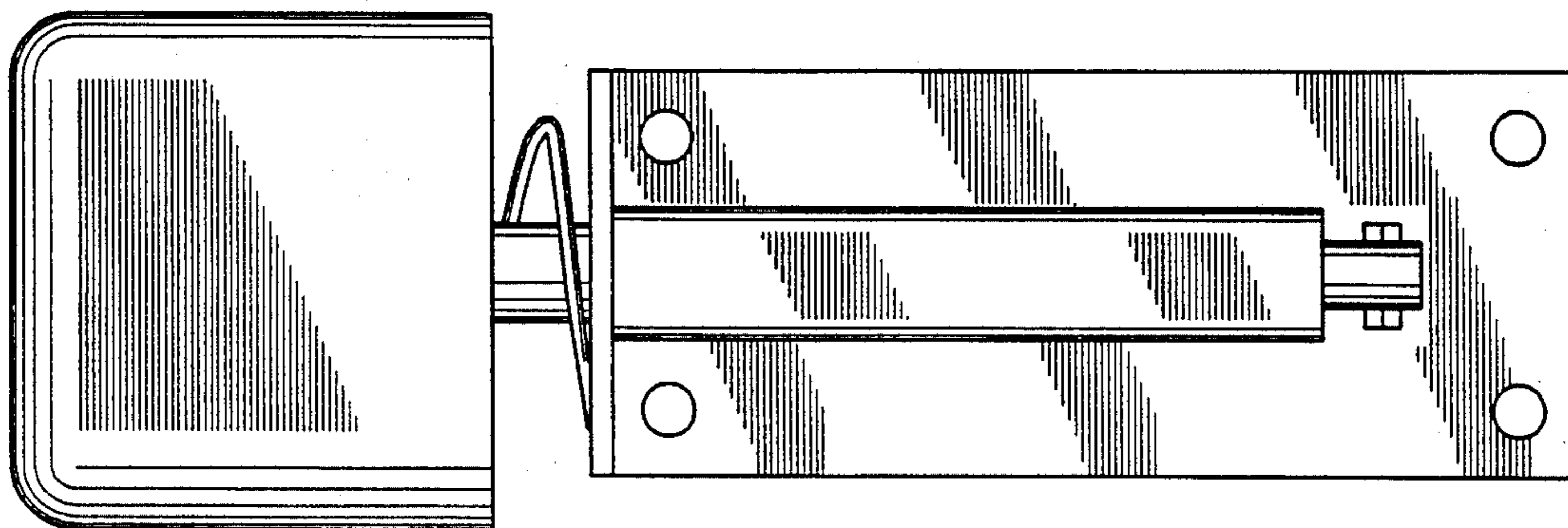

FIG. 4

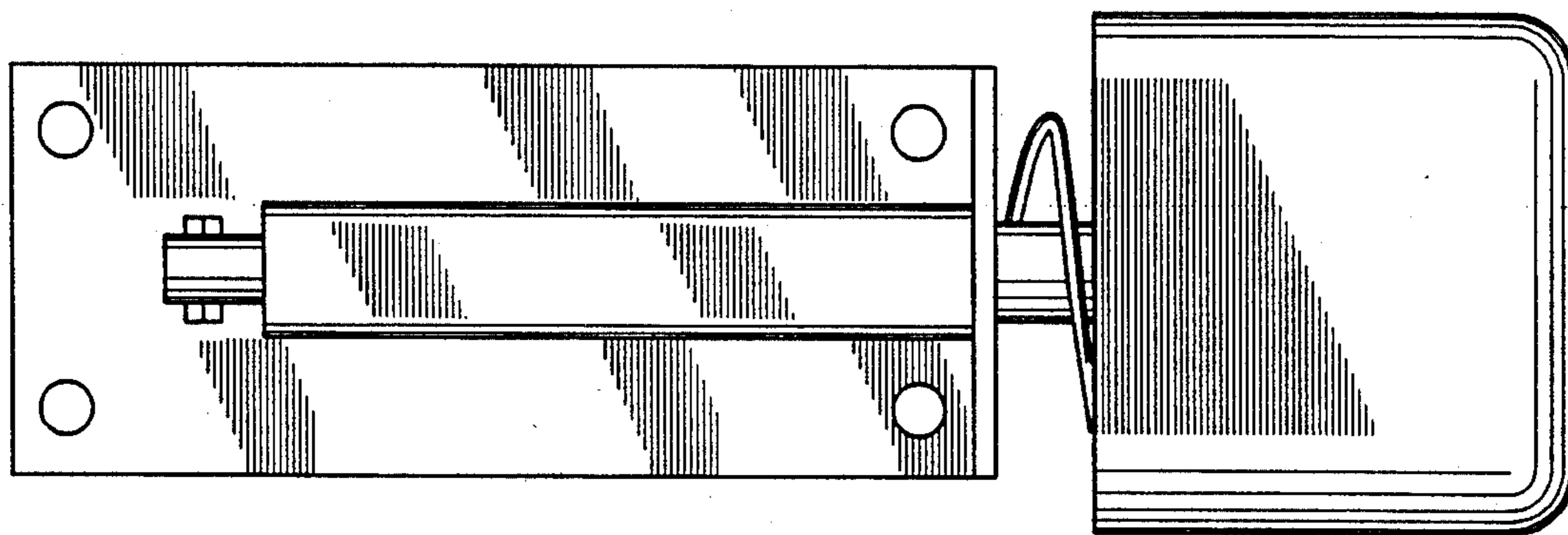

FIG. 5

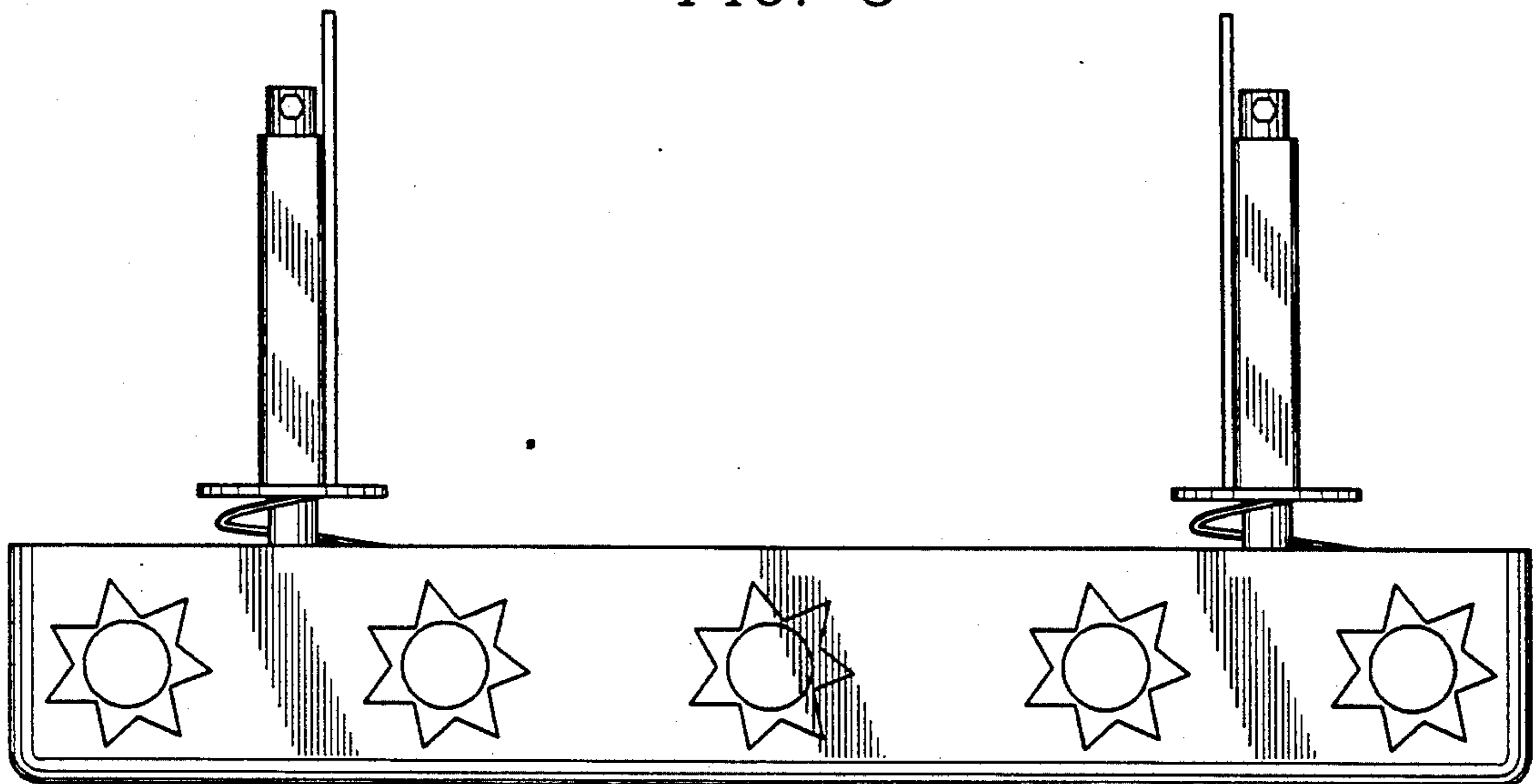

FIG. 6

