



US00D330714S

# United States Patent [19]

[11] Patent Number: **Des. 330,714**

**Kimura**

[45] Date of Patent: **\*\* Nov. 3, 1992**

[54] **PORTABLE HYDRAULIC PUNCHING INSTRUMENT**

3,924,330	12/1975	Mitsuhashi et al.	.....	30/362
4,468,995	9/1984	Mireles-Saldivac	.....	D15/128 X
4,731,929	3/1988	McClure	.....	30/361
4,786,215	11/1988	McClure	.....	408/79 X

[75] Inventor: **Kiyoshi Kimura, Fujisawa, Japan**

[73] Assignee: **Kabushiki Kaisha Ogura, Japan**

[\*\*] Term: **14 Years**

[21] Appl. No.: **440,013**

[22] Filed: **Nov. 21, 1989**

[30] **Foreign Application Priority Data**

May 22, 1989 [JP] Japan ..... 1-18559

[52] U.S. Cl. .... **D15/128; D15/127**

[58] Field of Search ..... **D8/61; D15/128, 127; 83/513, 514, 515, 516, 517, 518, 519, 33, 34, 50, 639.1, 684, 745; 408/1 R, 79; 30/360, 361, 358**

[56] **References Cited**

### U.S. PATENT DOCUMENTS

2,782,855	2/1957	Marcoux	.....	30/360
3,008,234	11/1961	Mattera	.....	30/358 X
3,126,630	3/1964	Catlin et al.	.....	30/358

*Primary Examiner*—Donald P. Walsh  
*Assistant Examiner*—Antoine D. Davis  
*Attorney, Agent, or Firm*—Bruce L. Adams; Van C. Wilks

### [57] CLAIM

The ornamental design for a portable hydraulic punching instrument, as shown and described.

### DESCRIPTION

FIG. 1 is a top, front and right side perspective view of a portable hydraulic punching instrument showing my new design;

FIG. 2 is a right side elevational view;

FIG. 3 is a left side elevational view;

FIG. 4 is a top plan view;

FIG. 5 is a bottom plan view;

FIG. 6 is a rear elevational view; and,

FIG. 7 is a front elevational view thereof.

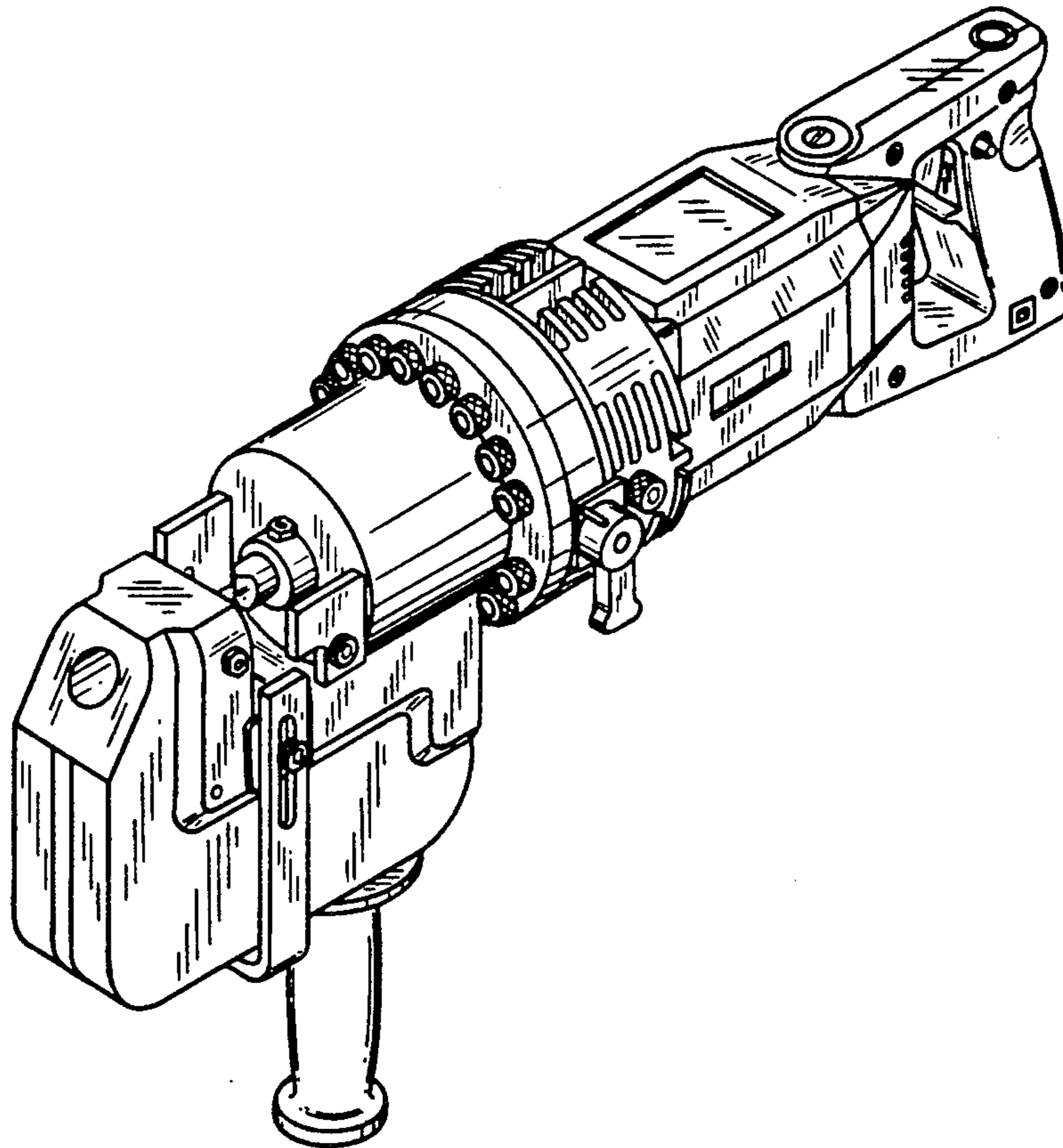

FIG. 1

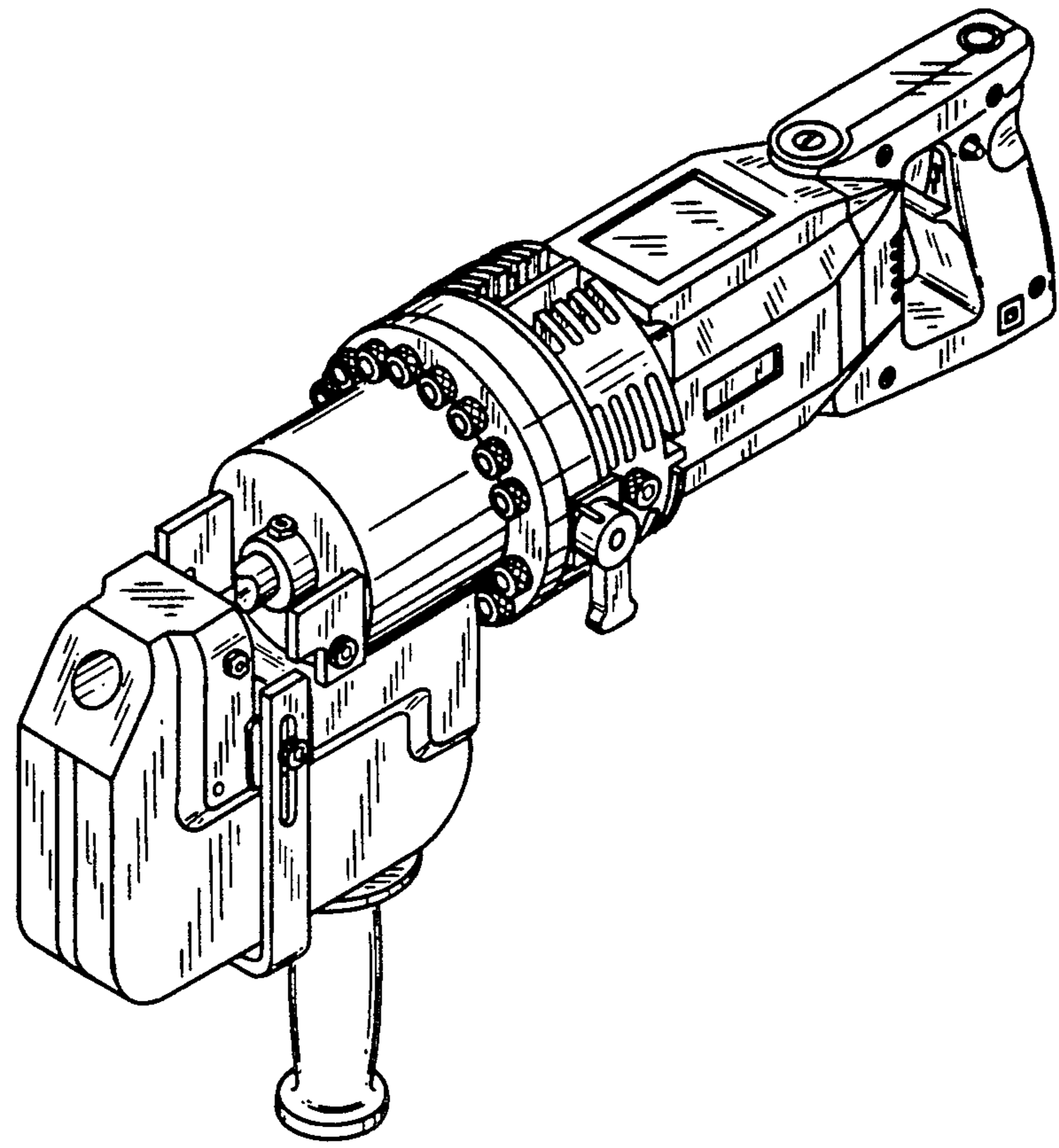

FIG. 2

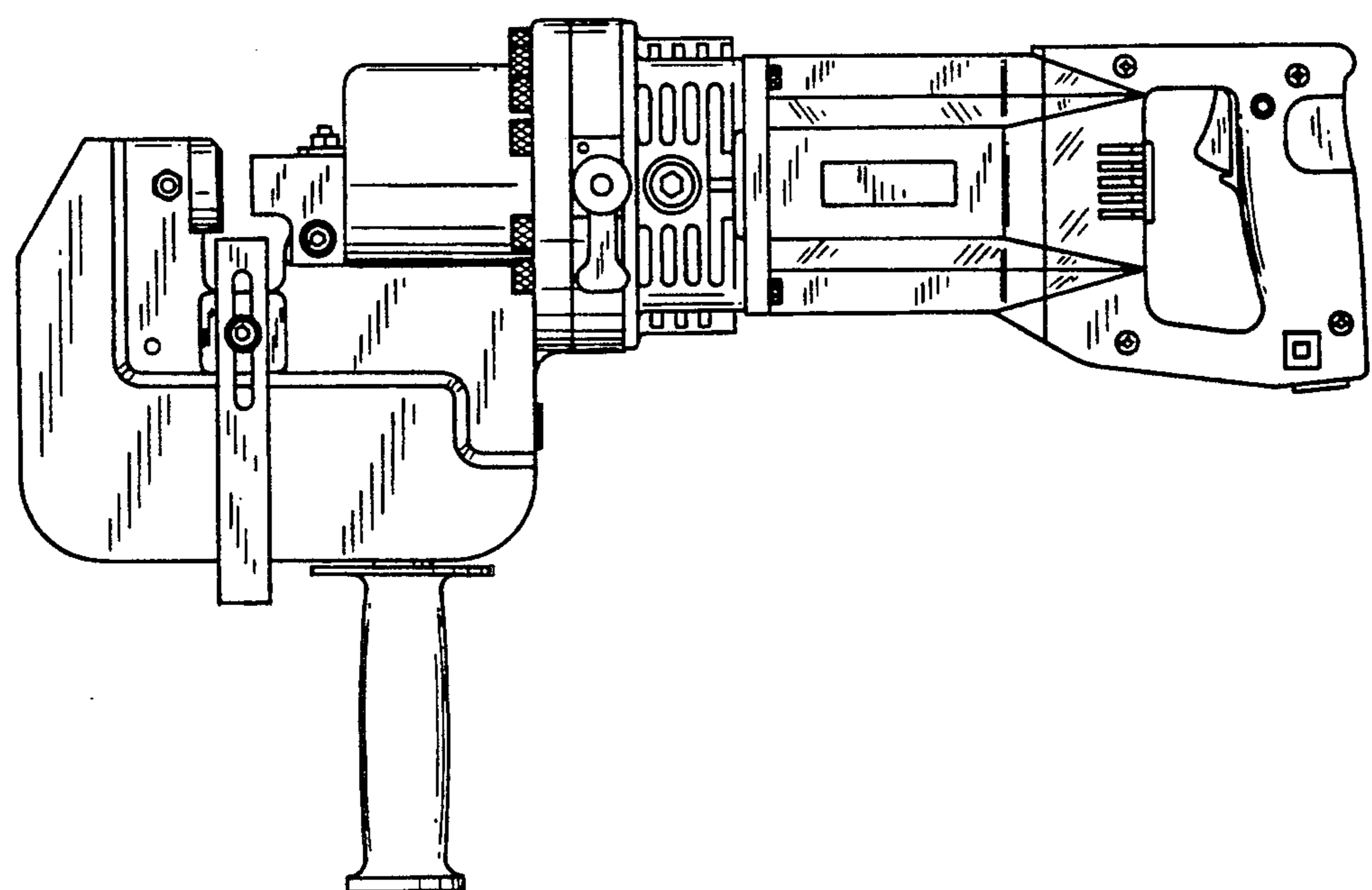

FIG. 3

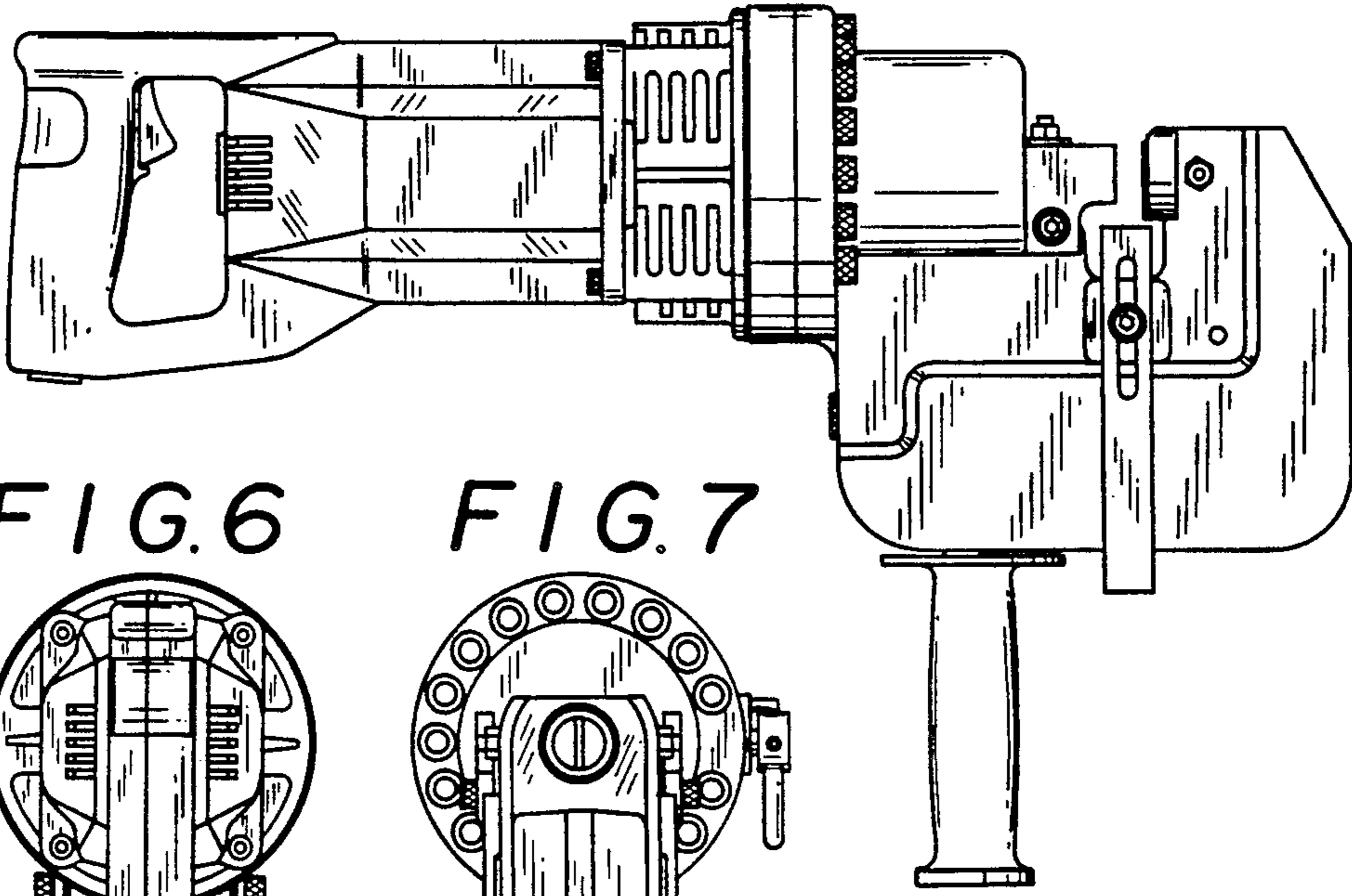

FIG. 6

FIG. 7

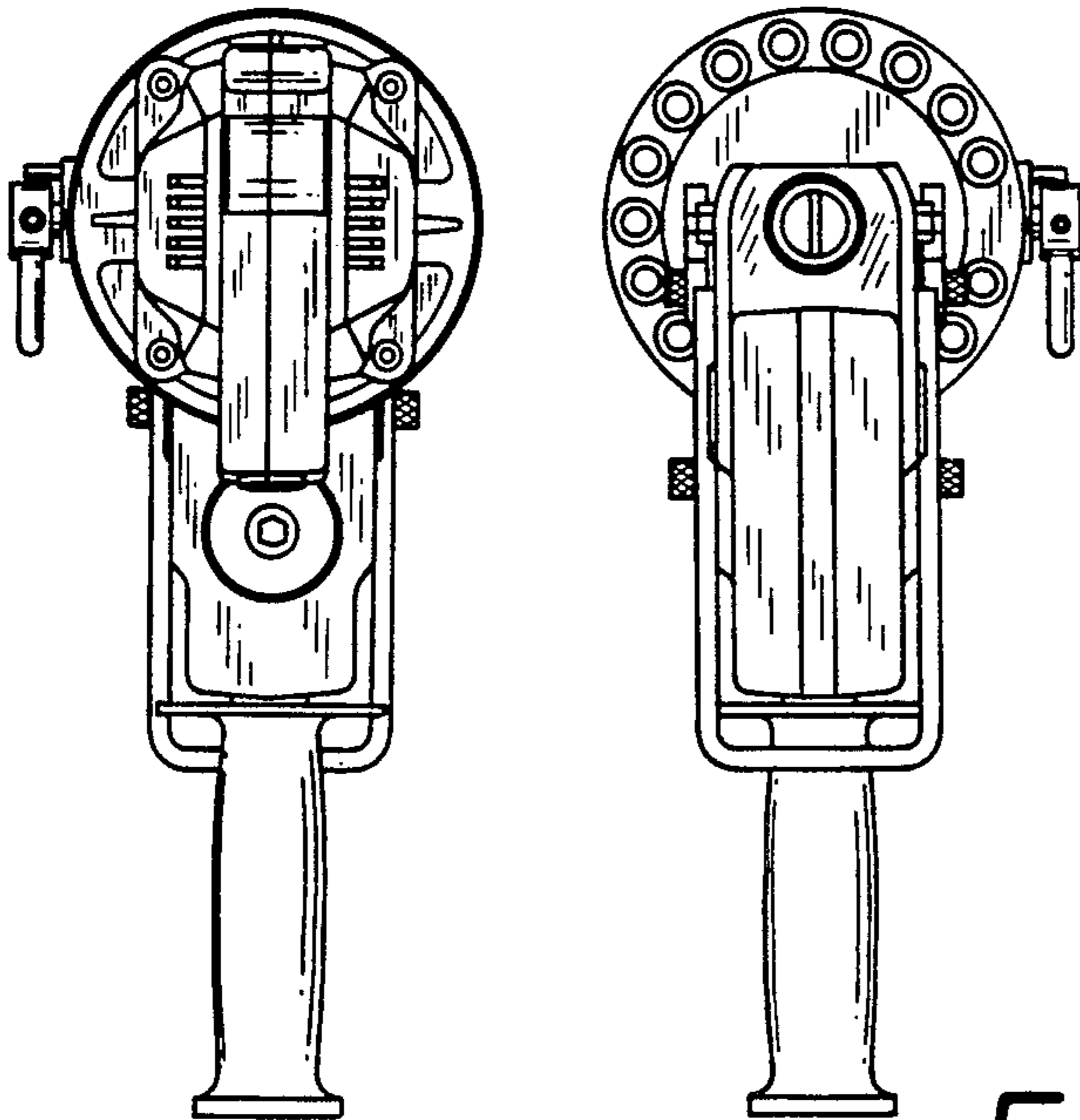

FIG. 4

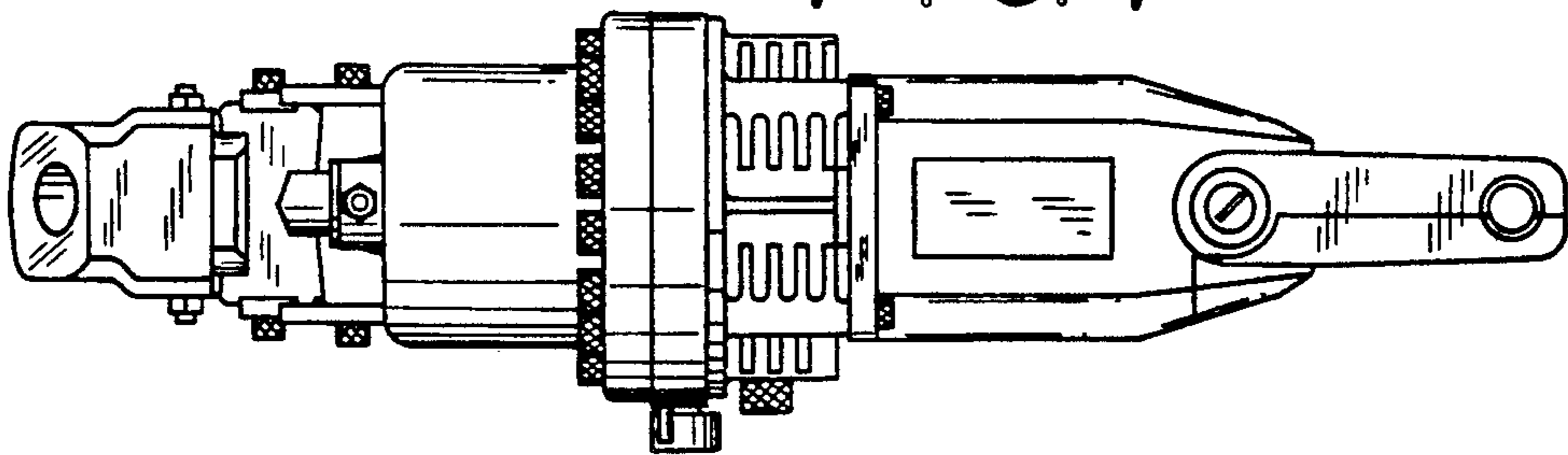

FIG. 5

