



US00D330692S

United States Patent [19]

Hammond, Jr.

[11] Patent Number: **Des. 330,692**

[45] Date of Patent: **** Nov. 3, 1992**

[54] **REMOVABLE MUD FLAP FOR VEHICLES**

4,726,599 2/1988 Antekeier et al. 280/154.5 R

[76] Inventor: **Arden D. Hammond, Jr.**, 721
Prescotts Heights Dr., Prescott,
Ariz. 86301

Primary Examiner—James M. Gandy
Attorney, Agent, or Firm—S. Pal Asija

[**] Term: **14 Years**

[57] **CLAIM**

The ornamental design for a removable mud flap for vehicles, as shown and described.

[21] Appl. No.: **700,907**

DESCRIPTION

[22] Filed: **May 17, 1991**

[52] U.S. Cl. **D12/185**

[58] Field of Search **D12/185; 280/851;**
D11/166; D10/109

FIG. 1 is a perspective view of the top, front and right side of a removable mud flap for vehicles showing my new design it being understood that the broken lines are for illustrative purposes only and form no part of the claimed design;

[56] **References Cited**

U.S. PATENT DOCUMENTS

2,683,612	7/1954	Bacino	280/154.5
3,388,884	6/1968	Eggler et al.	248/224
3,401,953	9/1968	Prohl et al.	280/154.5
3,700,260	10/1972	Moore et al.	280/154.5 R
3,711,119	1/1973	Hollingsworth	280/154.5 R
3,934,901	1/1976	Hammerly	280/154.5 R
4,627,594	12/1986	Reed	248/632

FIG. 2 is a front elevation view thereof;
FIG. 3 is a rear elevation view thereof;
FIG. 4 is a right side elevation view thereof;
FIG. 5 is a left side elevation view thereof;
FIG. 6 is a top plan view thereof;
FIG. 7 is a bottom plan view thereof; and,
FIG. 8 is an enlarged fragmentary right side elevation view of the upper portion thereof shown in greater detail.

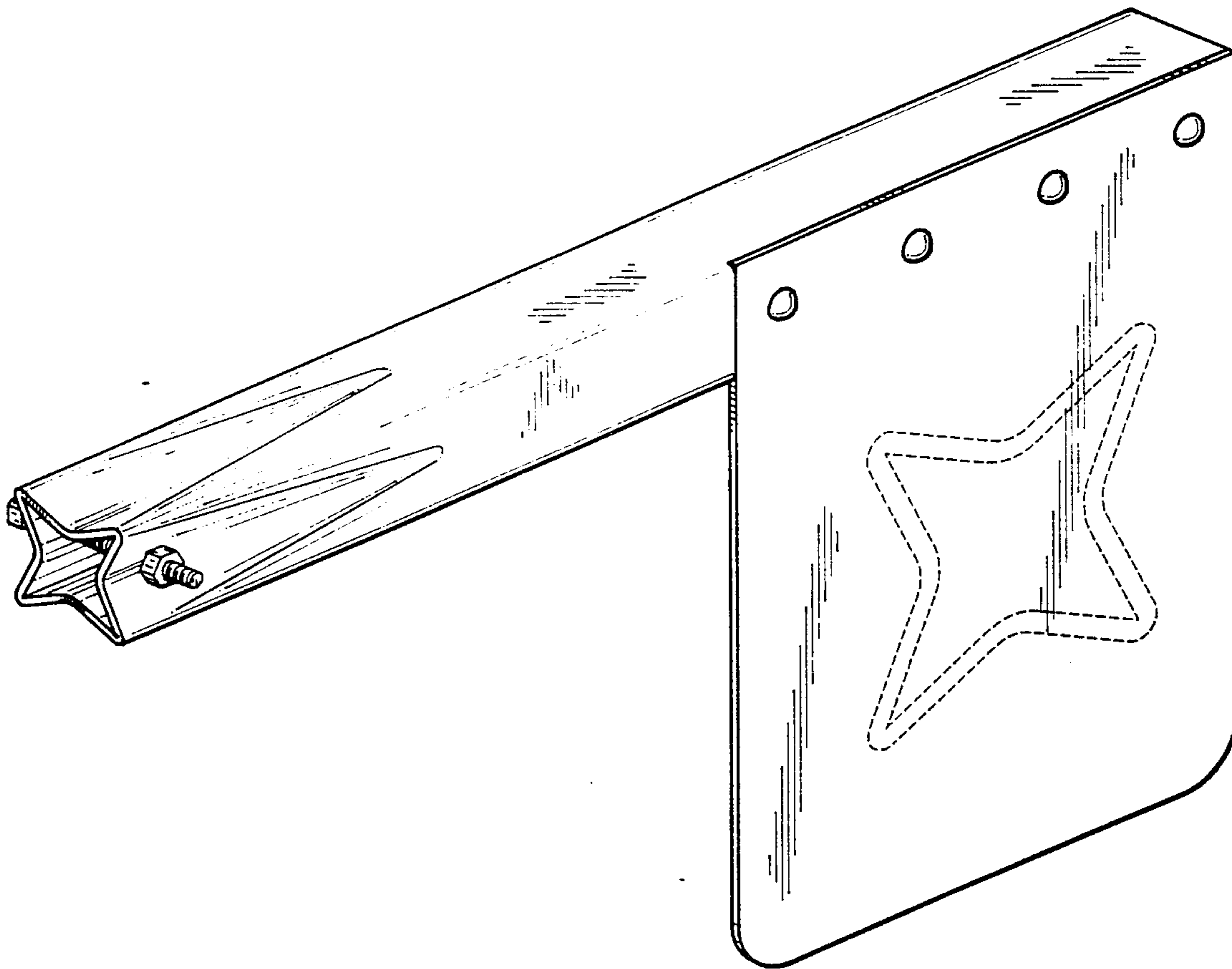

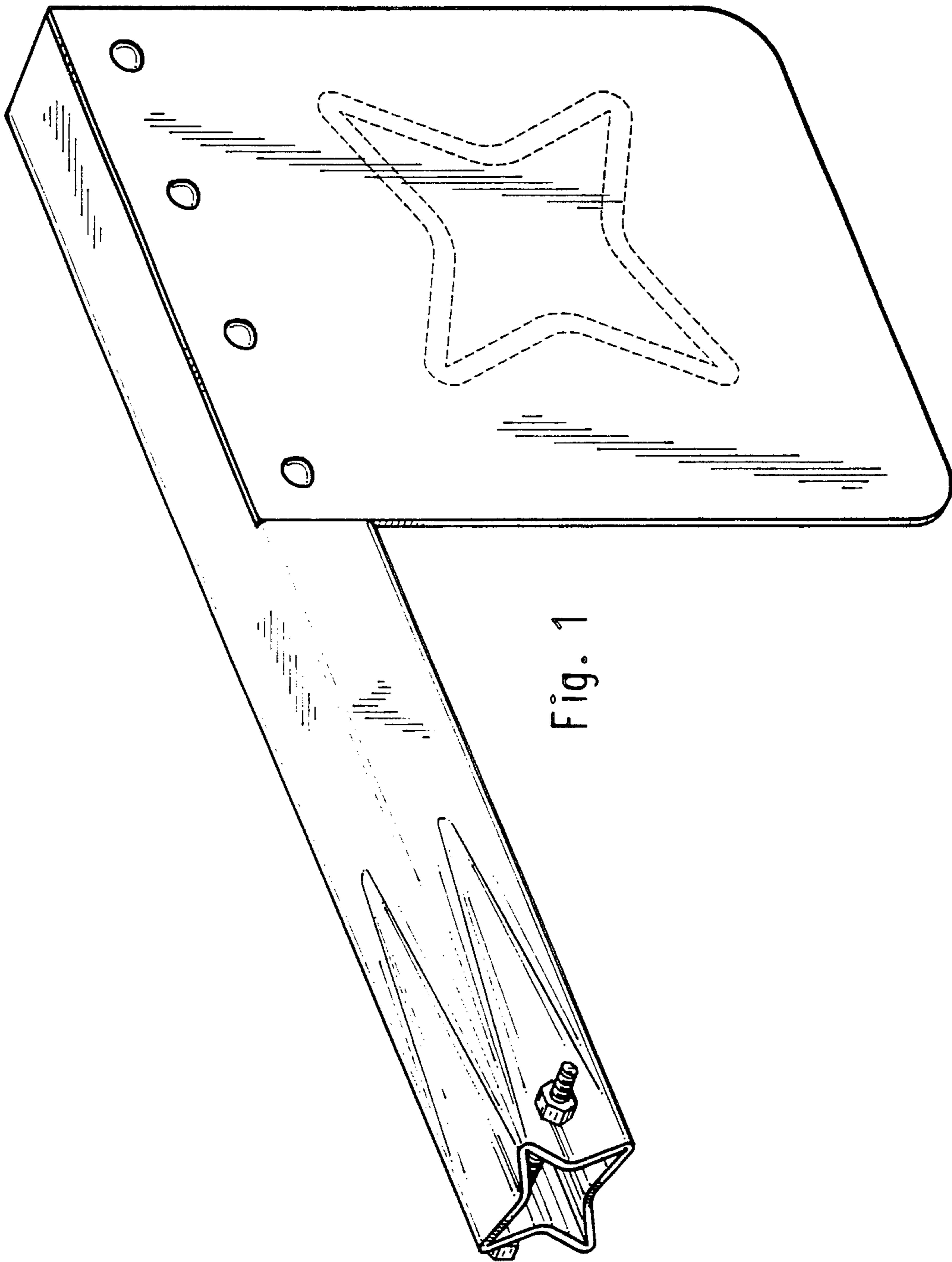

Fig. 1

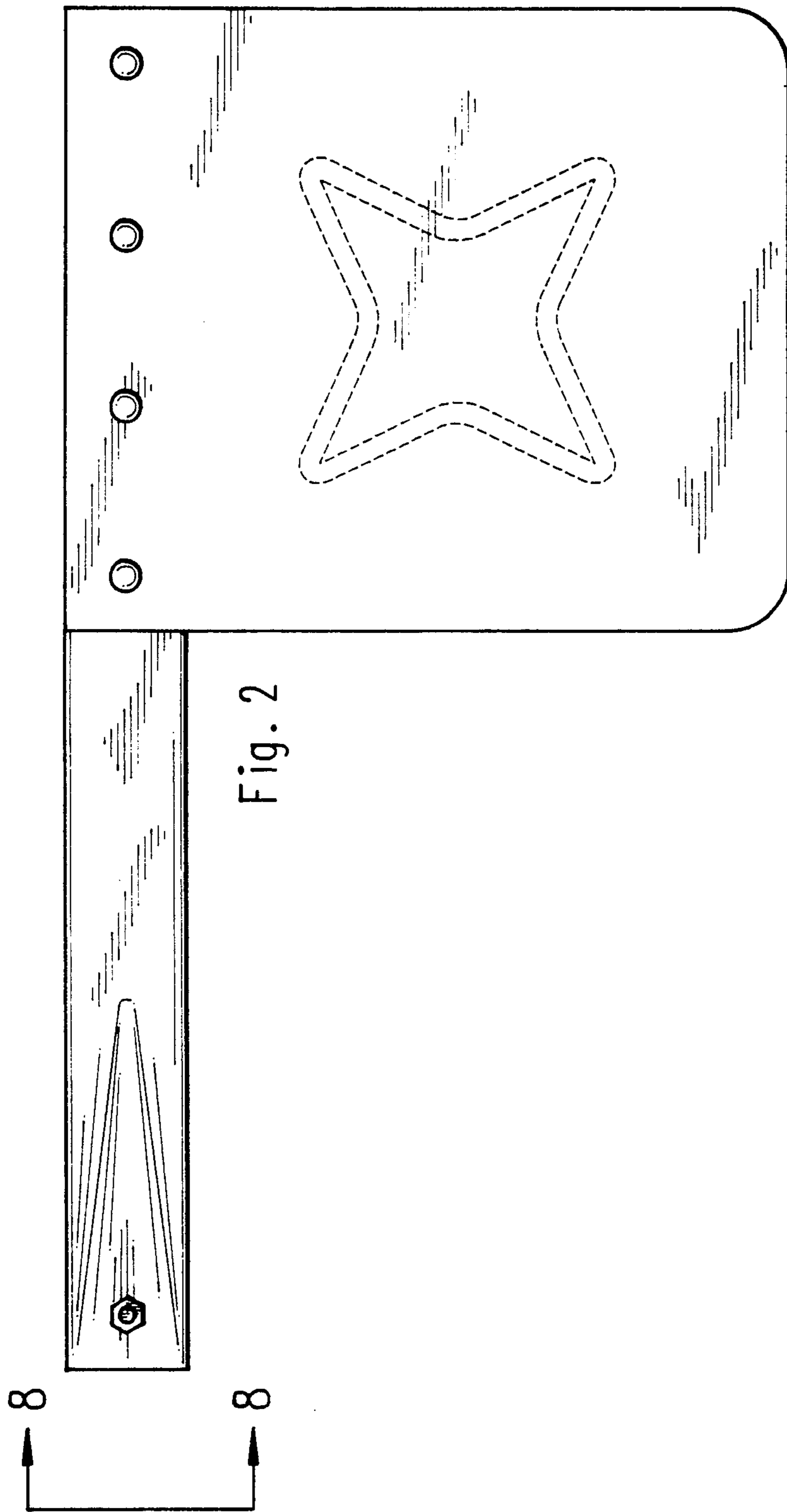

Fig. 2

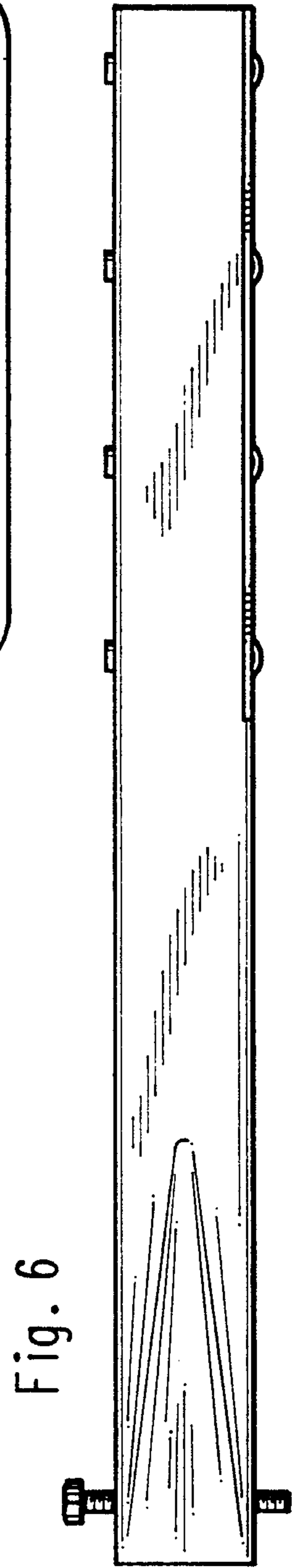

Fig. 6

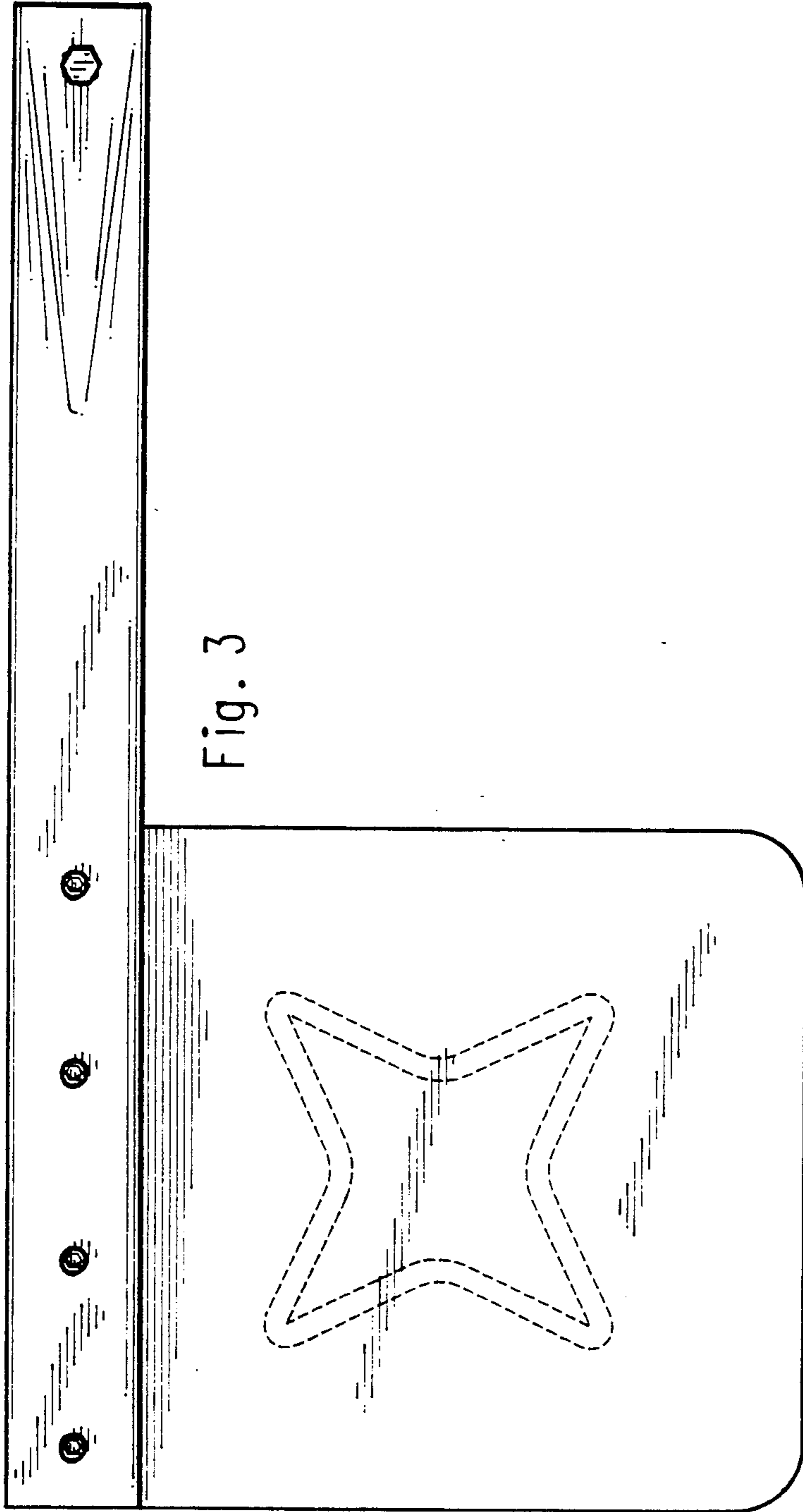

Fig. 3

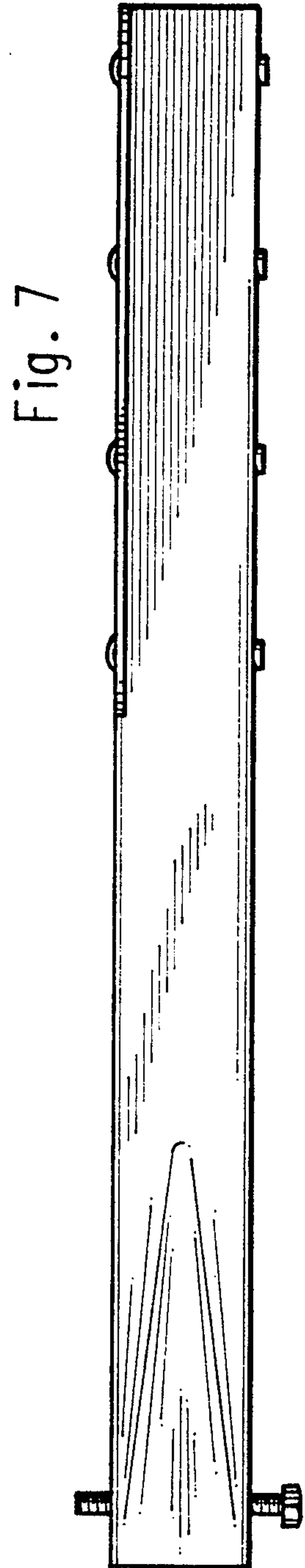

Fig. 7

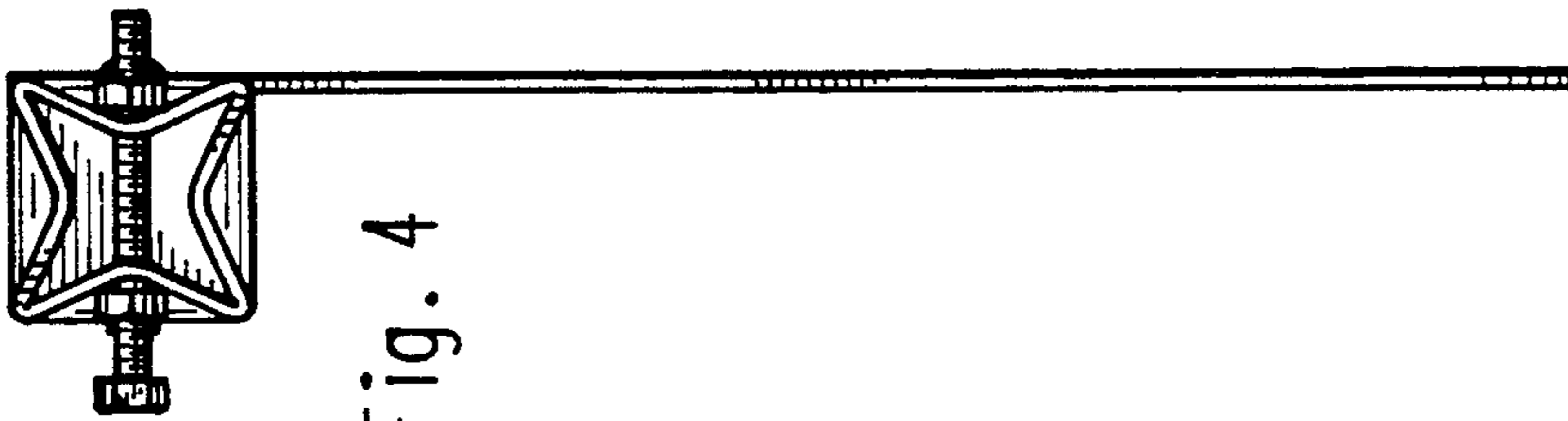

Fig. 4



Fig. 5

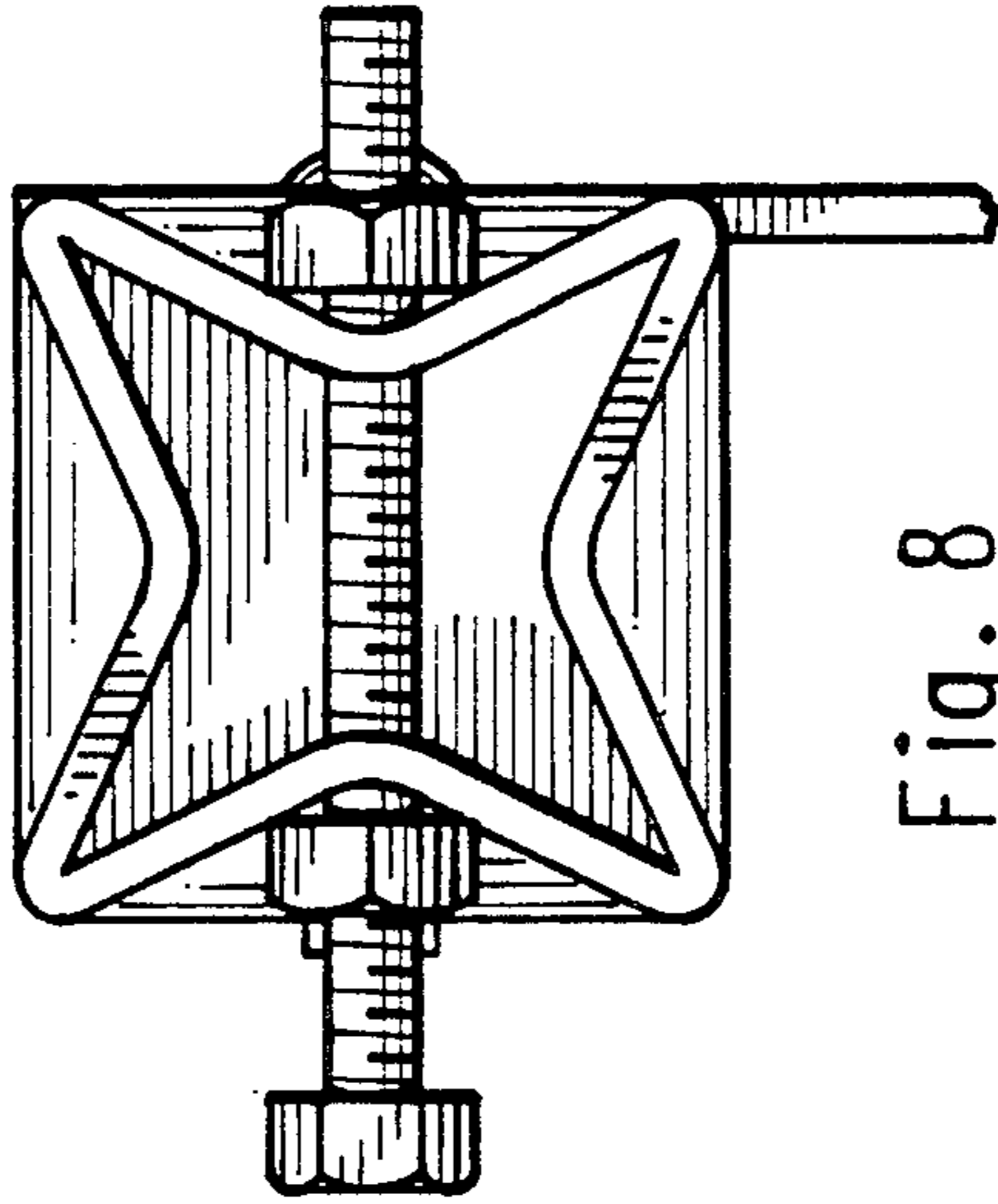

Fig. 8