



US00D330556S

# United States Patent [19]

Stires, Jr.

[11] Patent Number: **Des. 330,556**

[45] Date of Patent: **\*\* Oct. 27, 1992**

[54] **AIR VENT VALVE FOR AN INTERNAL COMBUSTION ENGINE FUEL HEAT SYSTEM**

[76] Inventor: **Sylvester Stires, Jr.**, 9405 Elm Ave., Fontana, Calif. 92335

[\*\*] Term: **14 Years**

[21] Appl. No.: **501,511**

[22] Filed: **Mar. 30, 1990**

[52] U.S. Cl. .... **D15/5; D15/9.1**

[58] Field of Search ..... **D15/1-5, D15/9.1; D12/317; 123/522, 557**

[56] **References Cited**

**U.S. PATENT DOCUMENTS**

D. 259,934	7/1981	Lovret .....	D15/5
D. 260,810	9/1981	Cleveland .....	D15/5
D. 314,548	2/1991	Whitley, II .....	D12/317
4,836,173	6/1989	Stires, Jr. ....	123/522

*Primary Examiner*—A. Hugo Word  
*Assistant Examiner*—R. Seifert  
*Attorney, Agent, or Firm*—John H. Crowe

[57] **CLAIM**

The ornamental design for an air vent valve for an internal combustion engine fuel heat system, as shown and described.

**DESCRIPTION**

FIG. 1 is a perspective view of an air vent valve for an internal combustion engine fuel heat system showing my new design;

FIG. 2 is a front elevational view shown on a reduced scale;

FIG. 3 is a rear elevational view thereof;

FIG. 4 is a top plan view thereof;

FIG. 5 is a bottom plan view thereof;

FIG. 6 is a left side elevational view thereof; and,

FIG. 7 is a right side elevational view thereof.

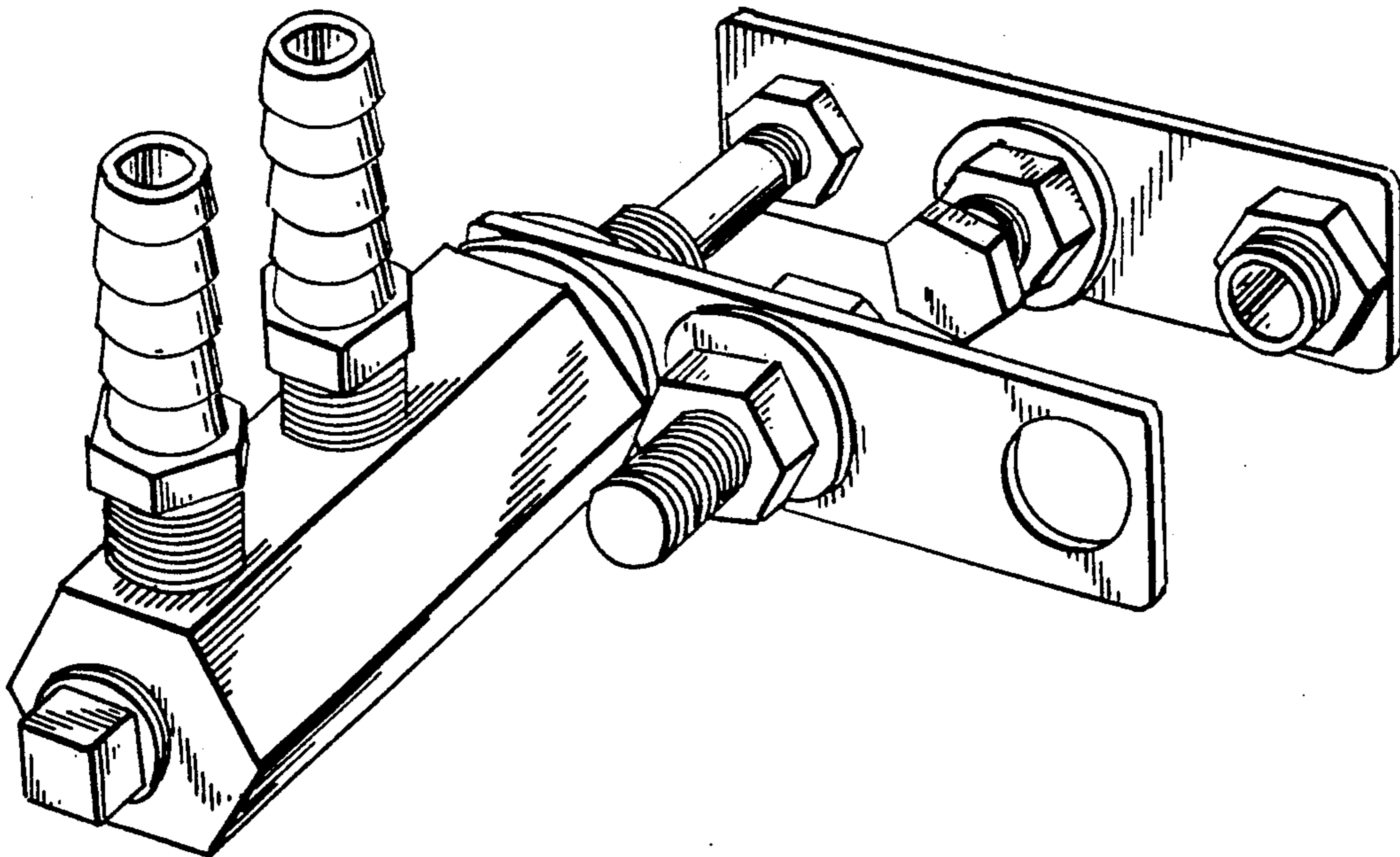

FIG. 1

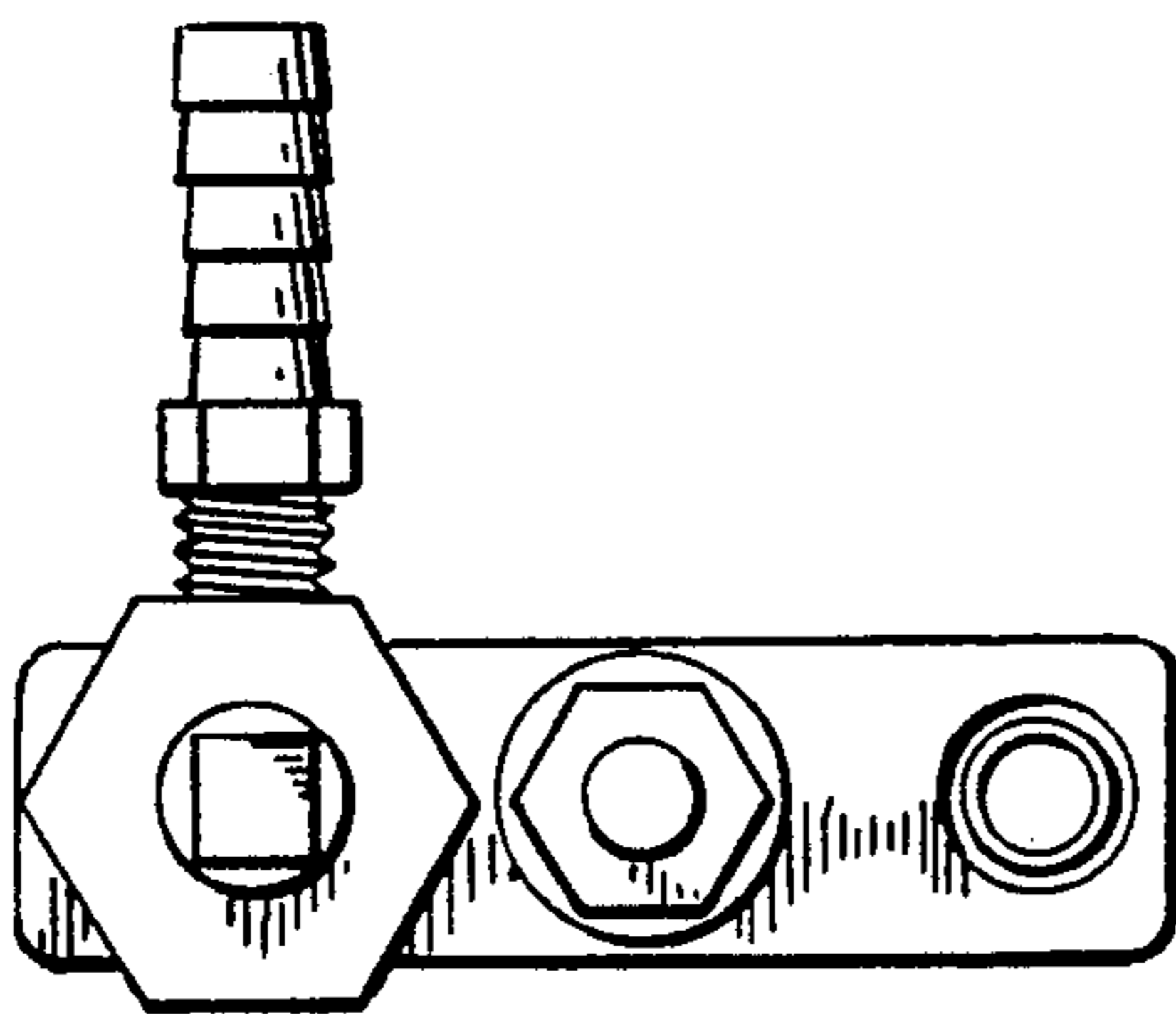
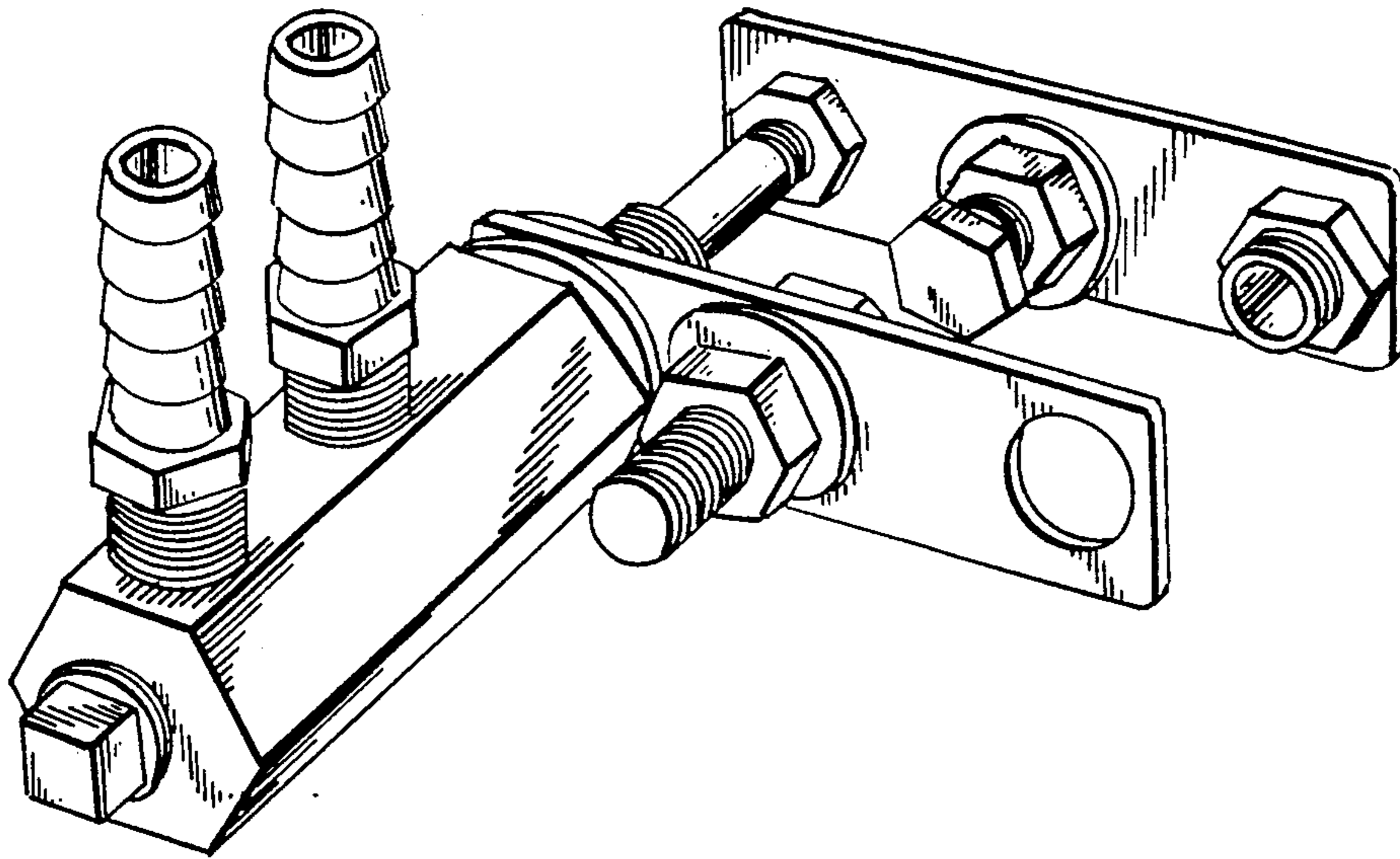

FIG. 2

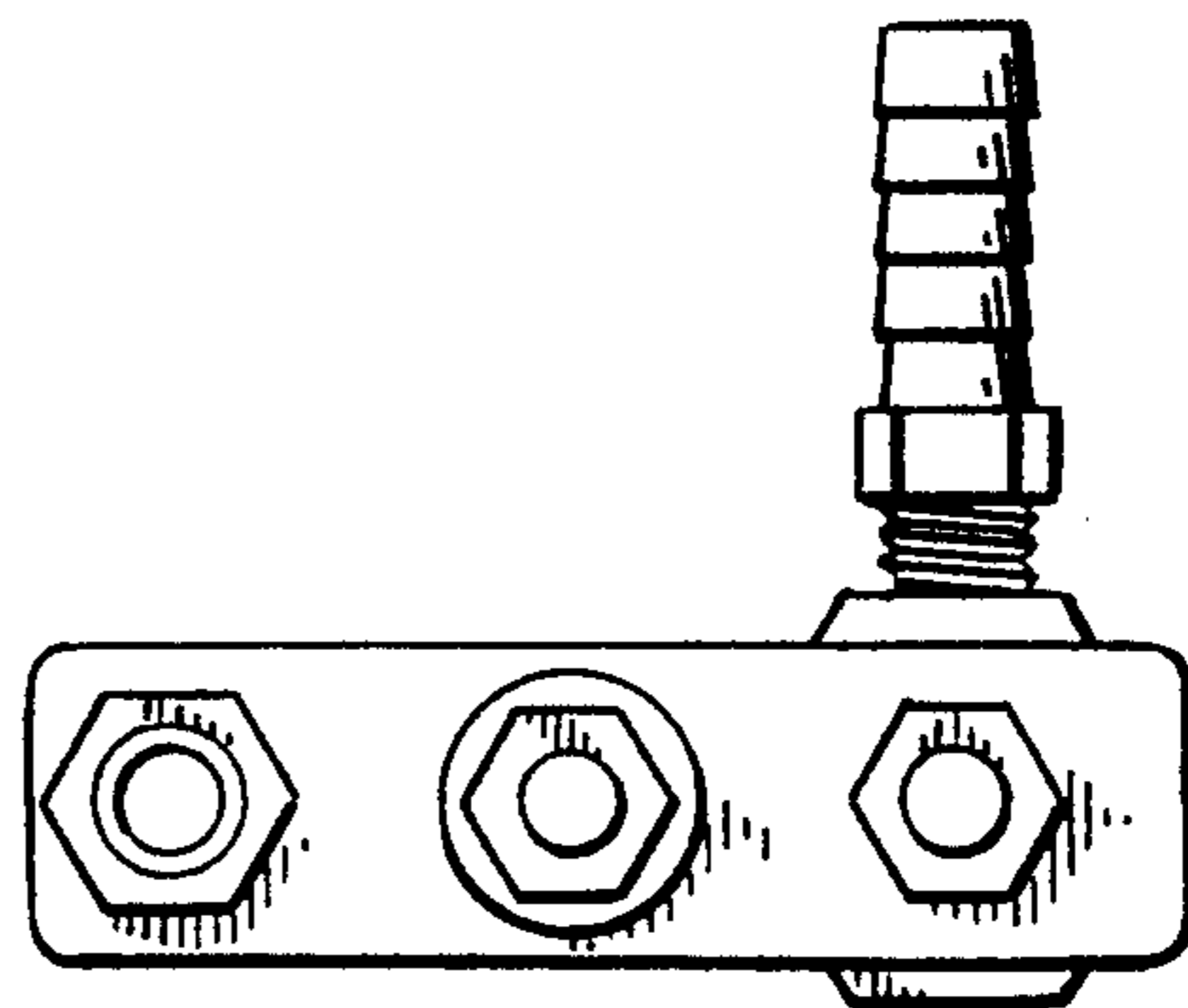

FIG. 3

FIG. 4

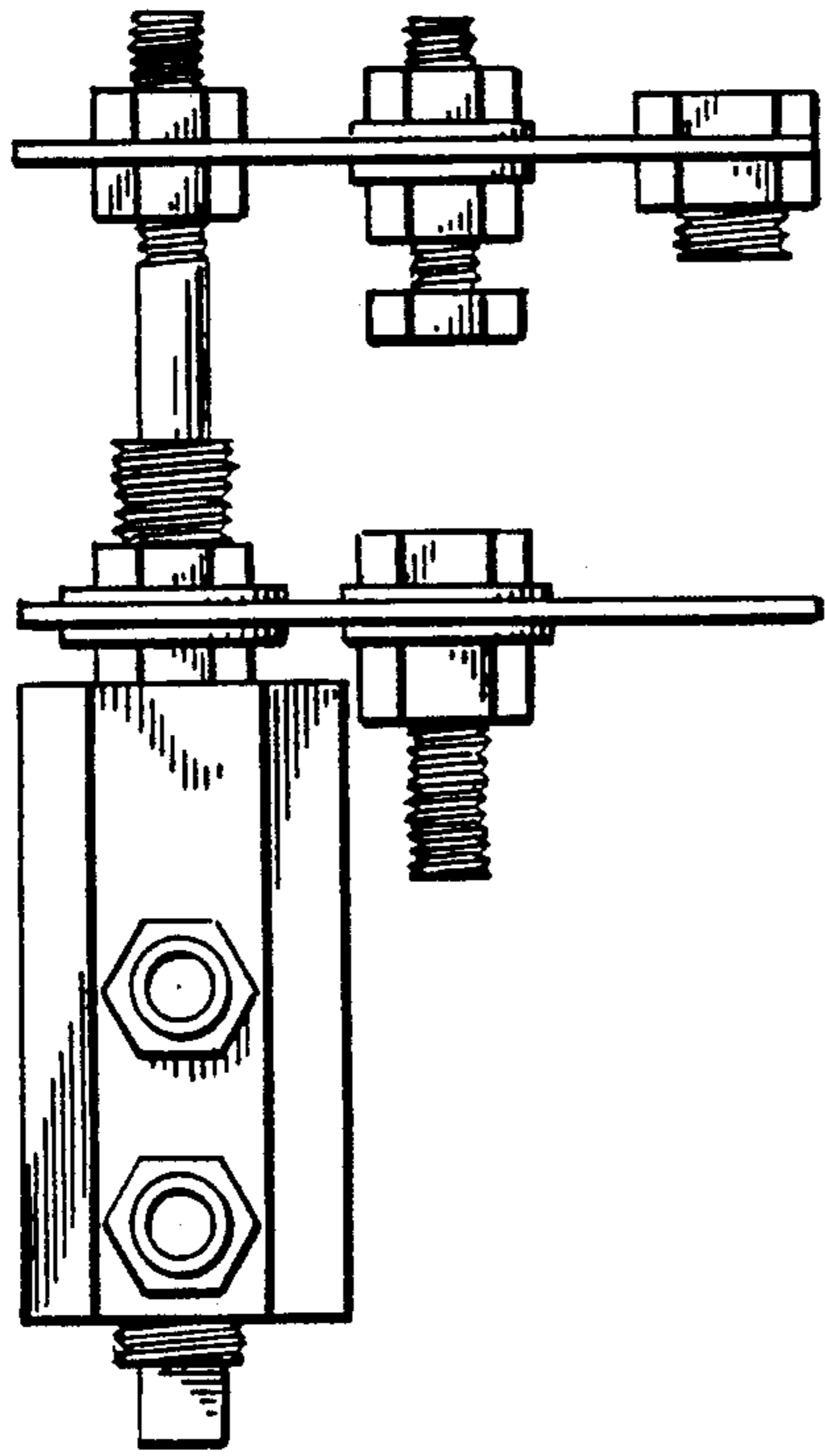

FIG. 5

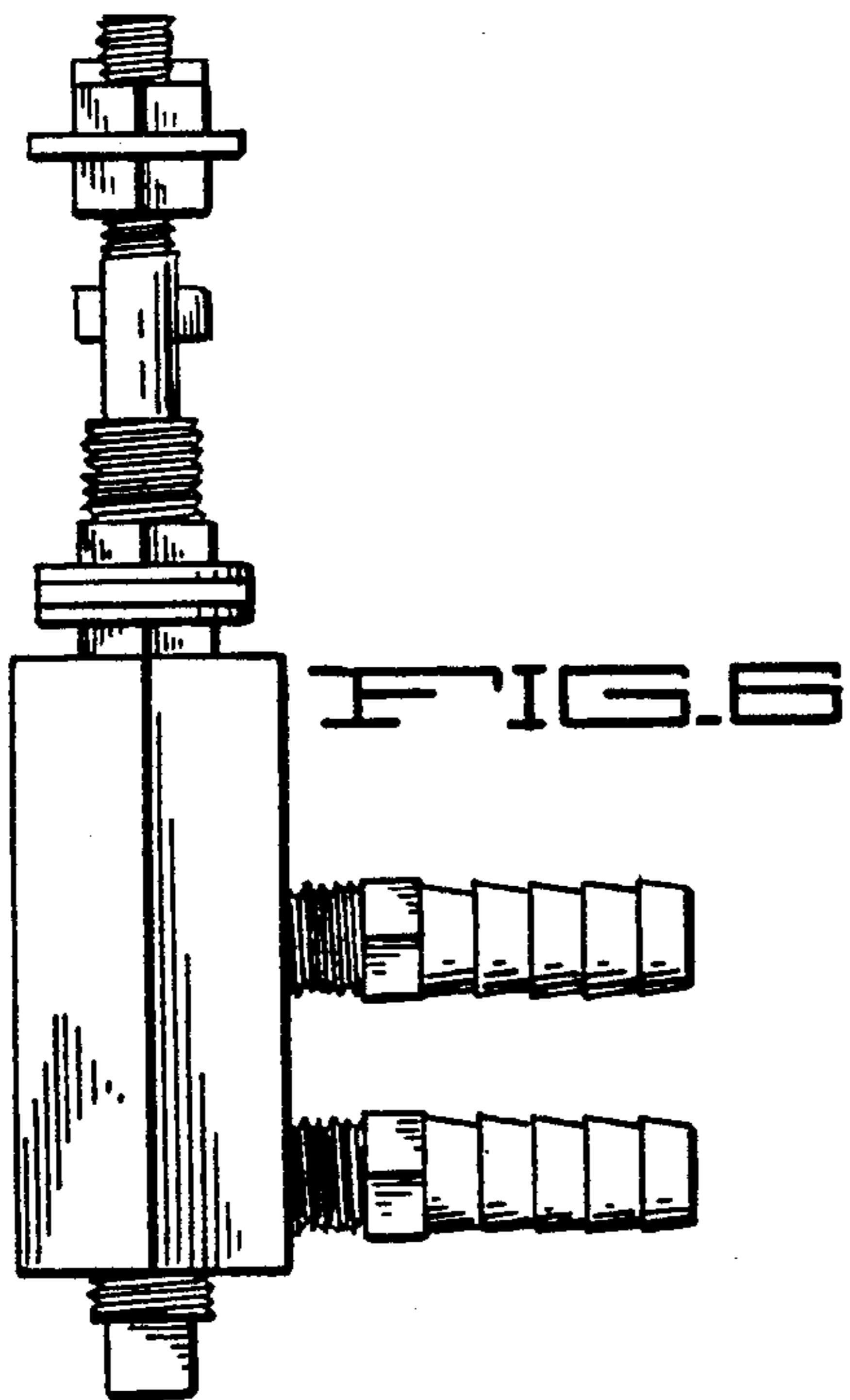
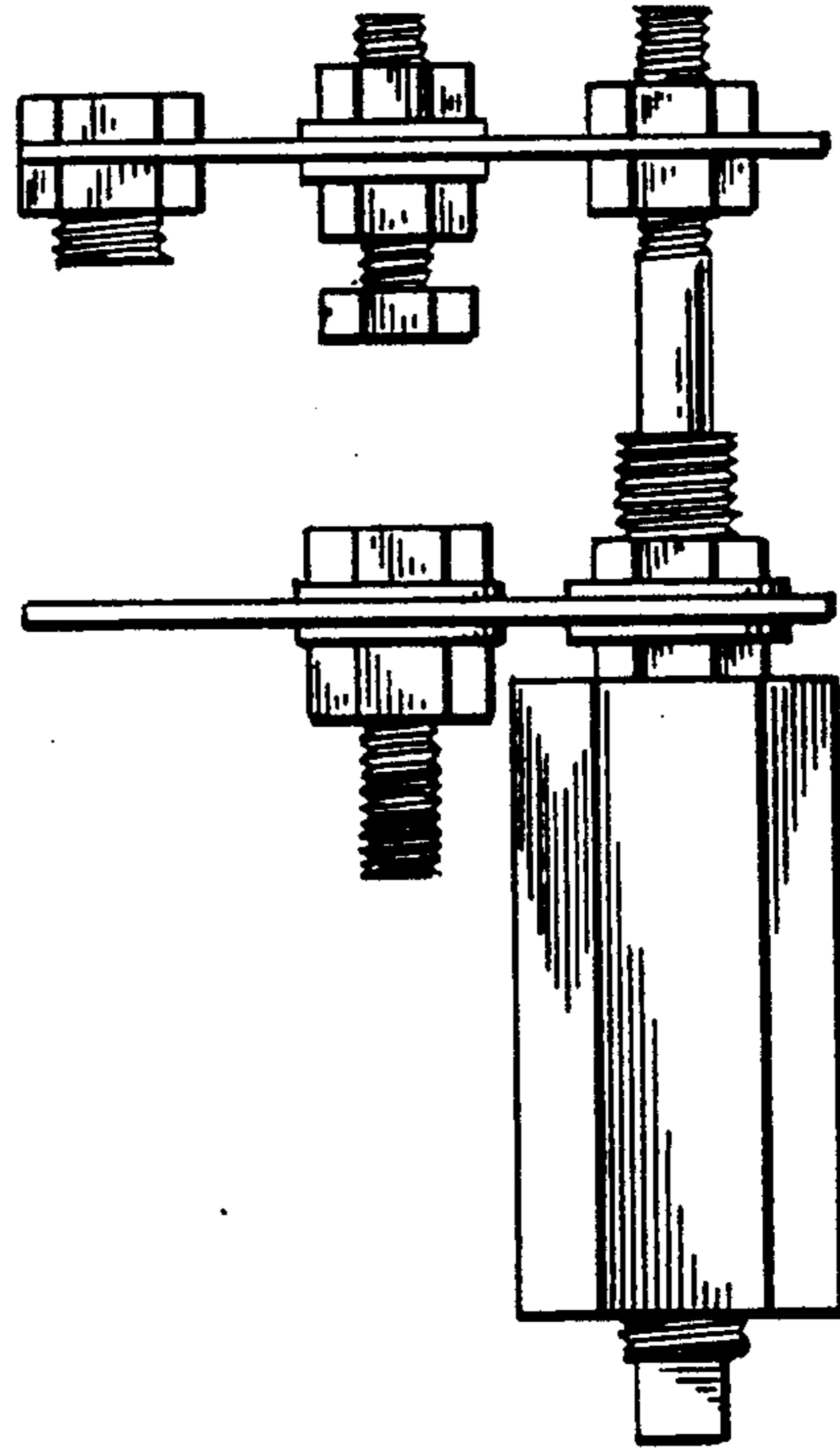

FIG. 7

