



US00D330500S

United States Patent [19] Chen

[11] Patent Number: **Des. 330,500**
[45] Date of Patent: **** Oct. 27, 1992**

[54] **AUTOMOBILE STEERING WHEEL LOCK**

5,115,652 5/1992 Starmer 70/209

[76] Inventor: **Tian-Yuan Chen, No. 95-4,
Min-Hsiang Road, Chung-Ho,
Taiwan**

Primary Examiner—Brian N. Vinson

[**] Term: **14 Years**

[57] **CLAIM**

The ornamental design for an automobile steering wheel lock, as shown and described.

[21] Appl. No.: **738,725**

DESCRIPTION

[22] Filed: **Jul. 22, 1991**

FIG. 1 is a top, front, and left side perspective view of an automobile steering wheel lock showing my new design;

[52] U.S. Cl. **D8/331**

FIG. 2 is a front elevational view thereof;

[58] Field of Search **D8/330-331,
D8/336, 338-339, 341-342; 70/207-211,
214-215, 225-226, 237-238; 292/289**

FIG. 3 is a rear elevational view thereof;

FIG. 4 is a left side elevational view thereof;

[56] **References Cited**

U.S. PATENT DOCUMENTS

3,828,593	8/1974	Bolton	70/209
4,829,797	5/1989	Wu	70/209
4,882,920	11/1989	Wu	70/209
5,052,201	10/1991	Liou	70/209
5,095,723	3/1992	Lin	70/226 X

FIG. 5 is a right side elevational view thereof;

FIG. 6 is a top plan view thereof;

FIG. 7 is a bottom plan view thereof; and,

FIG. 8 is a reduced top, front, and left side perspective view thereof, the partial broken-line disclosure of a steering wheel assembly being for illustrative purposes only and forming no part of the claimed design.

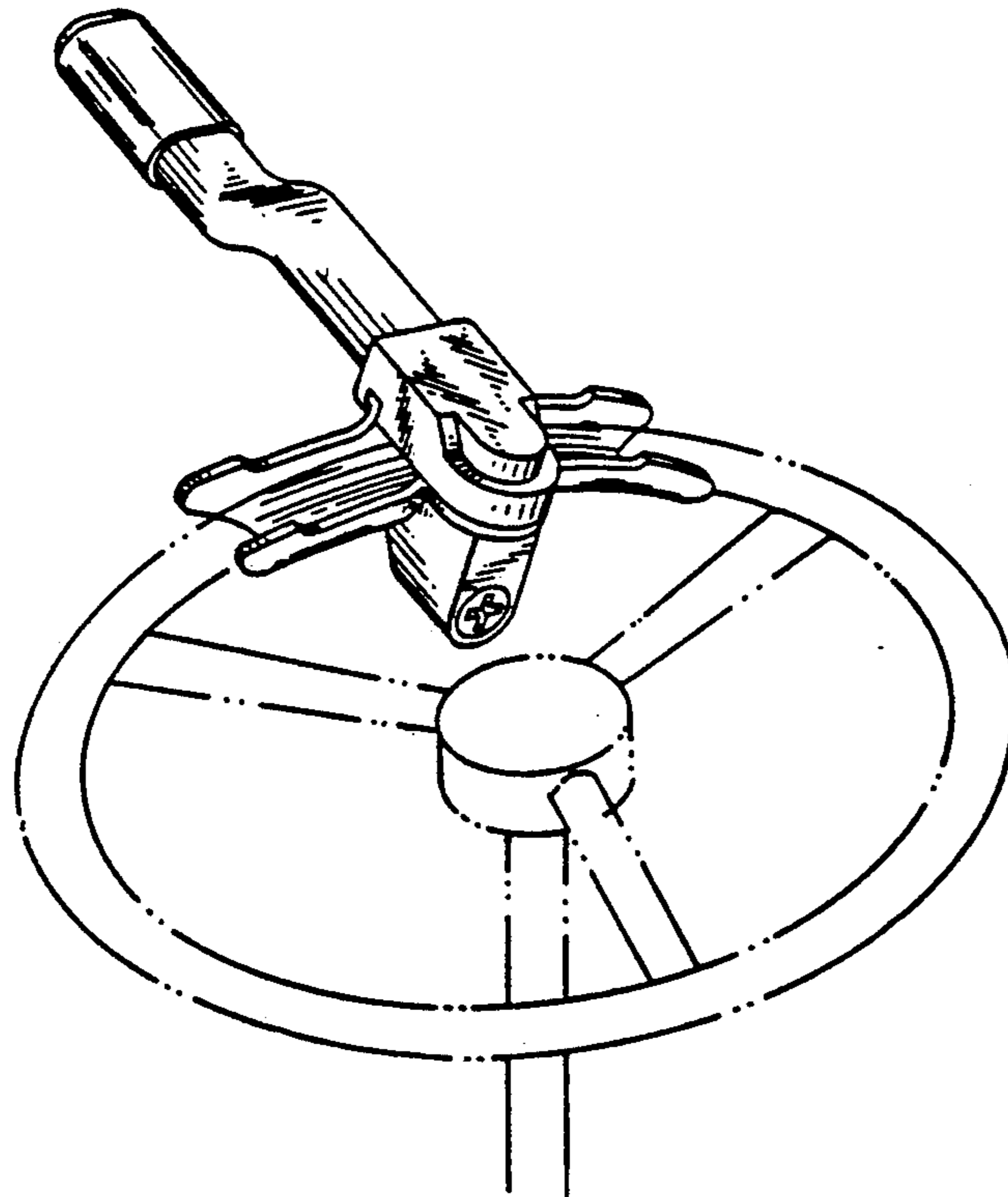

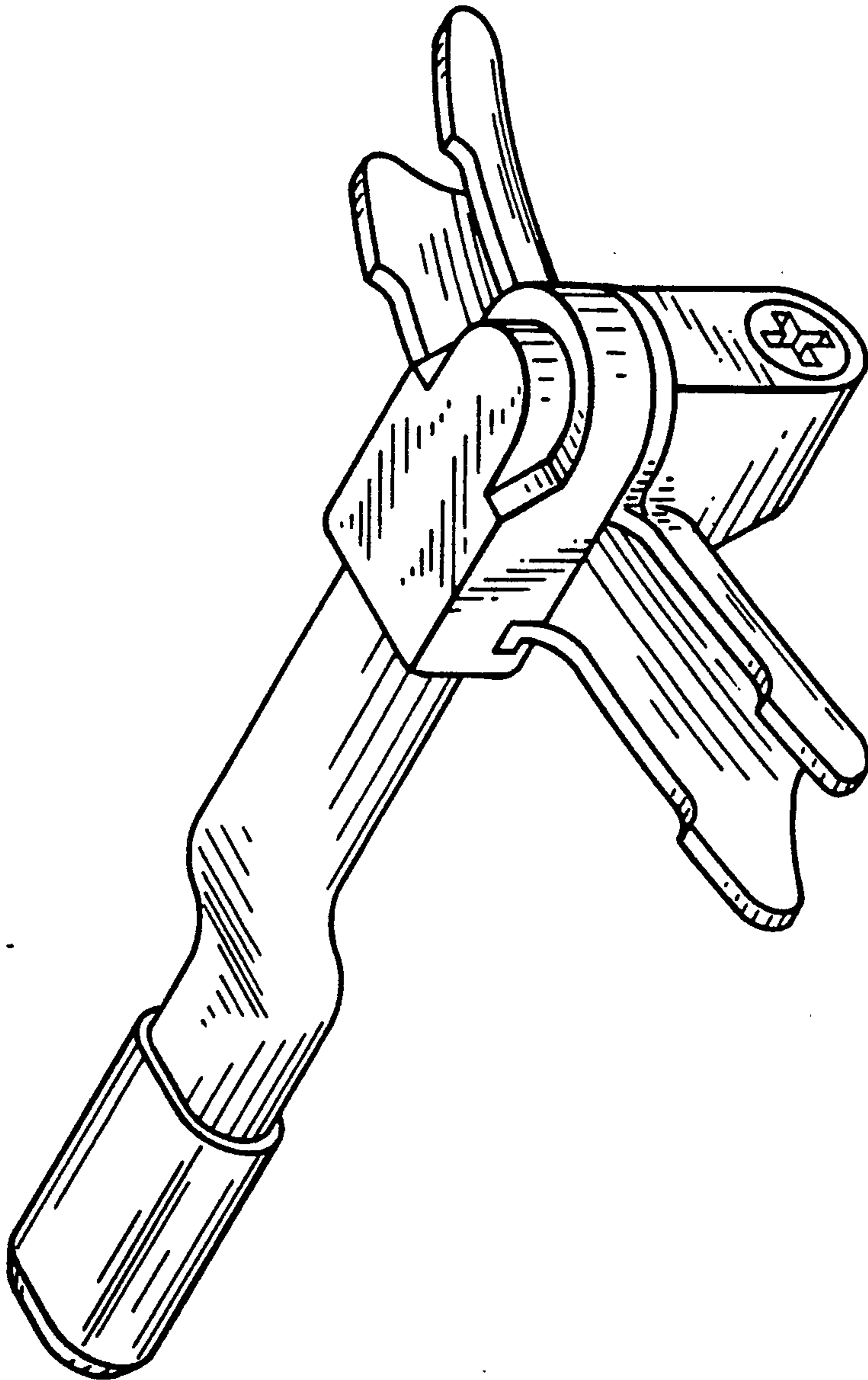

FIG. 1

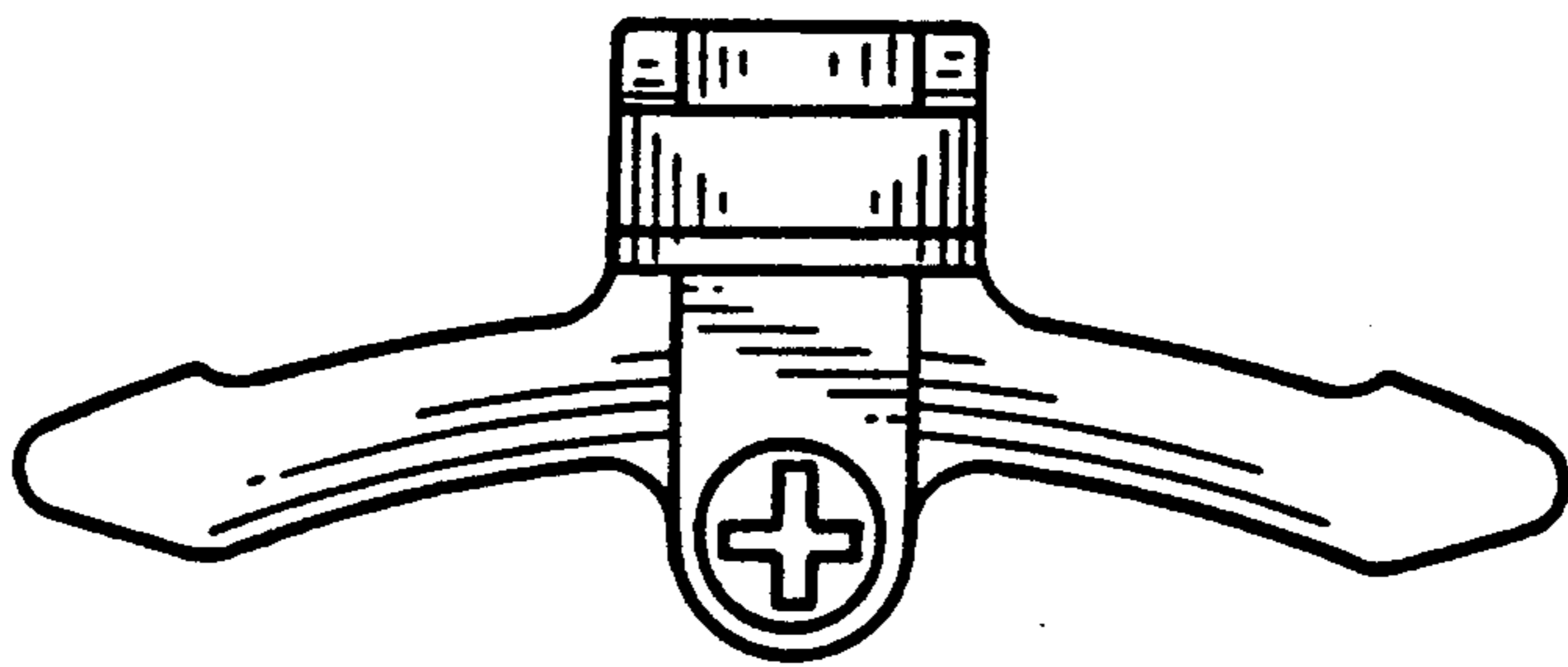

FIG. 2

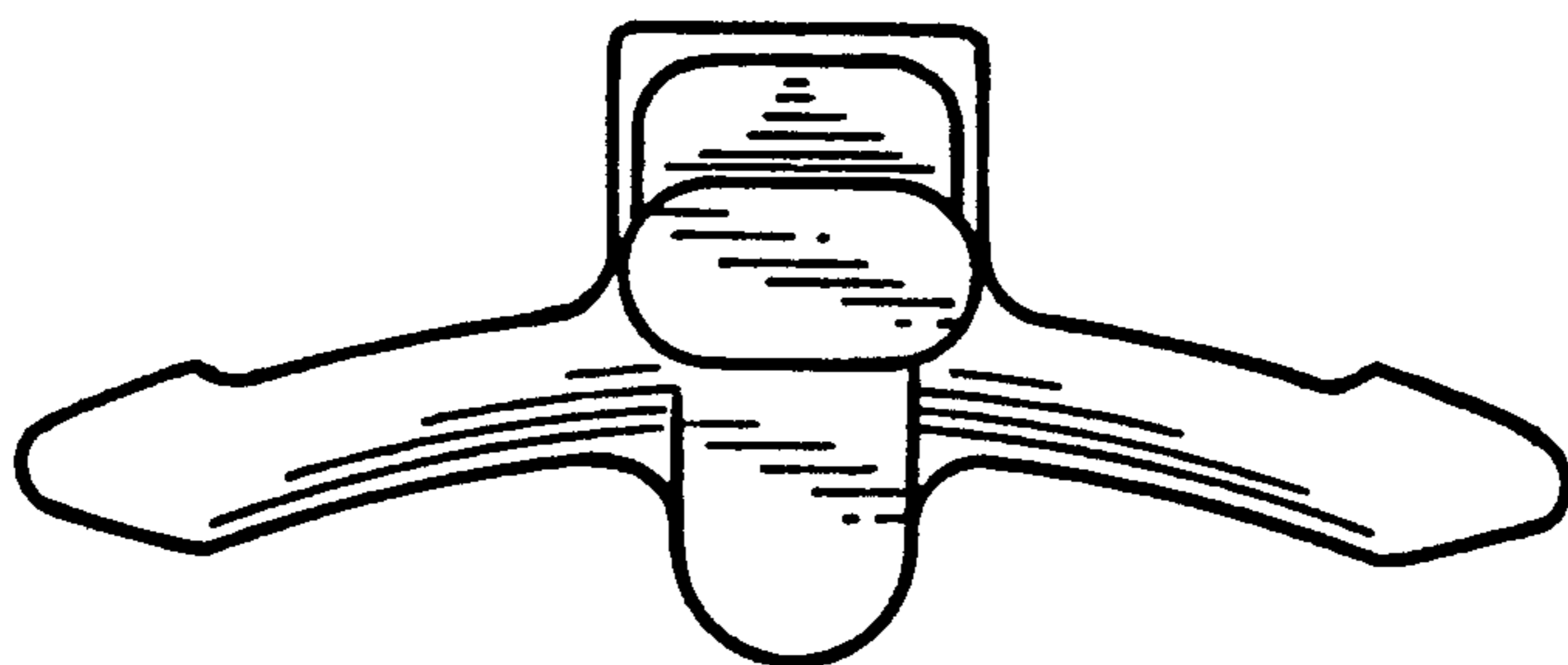

FIG. 3

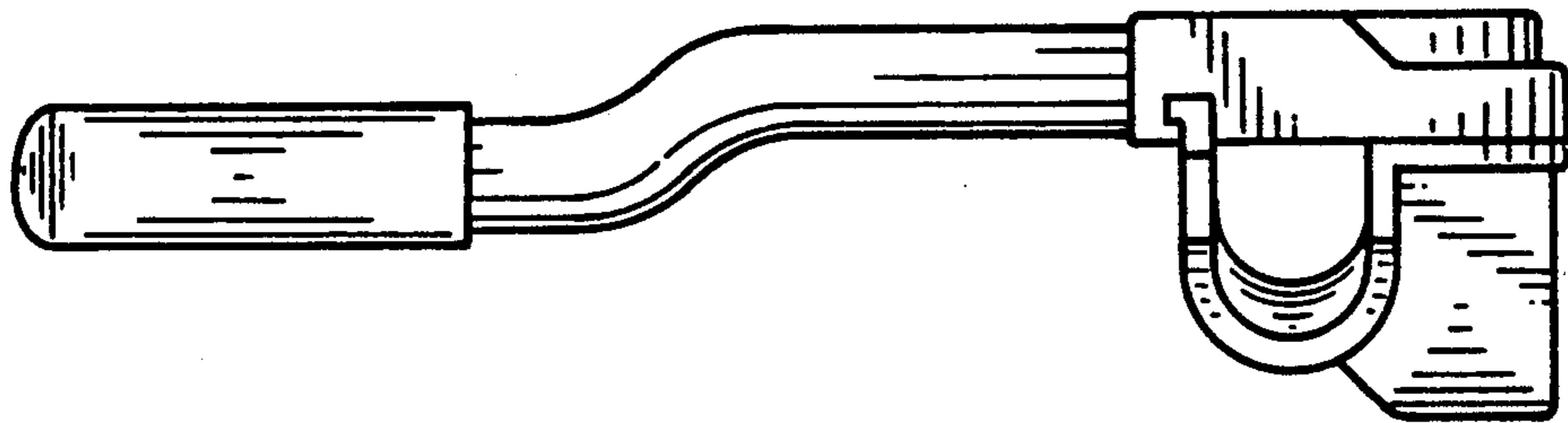

FIG. 4

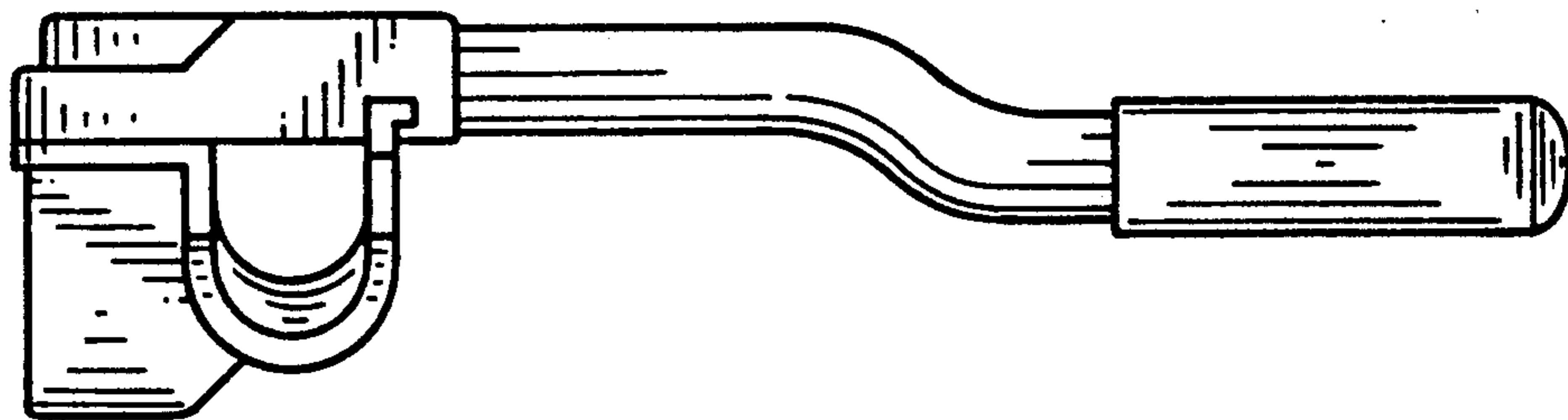

FIG. 5

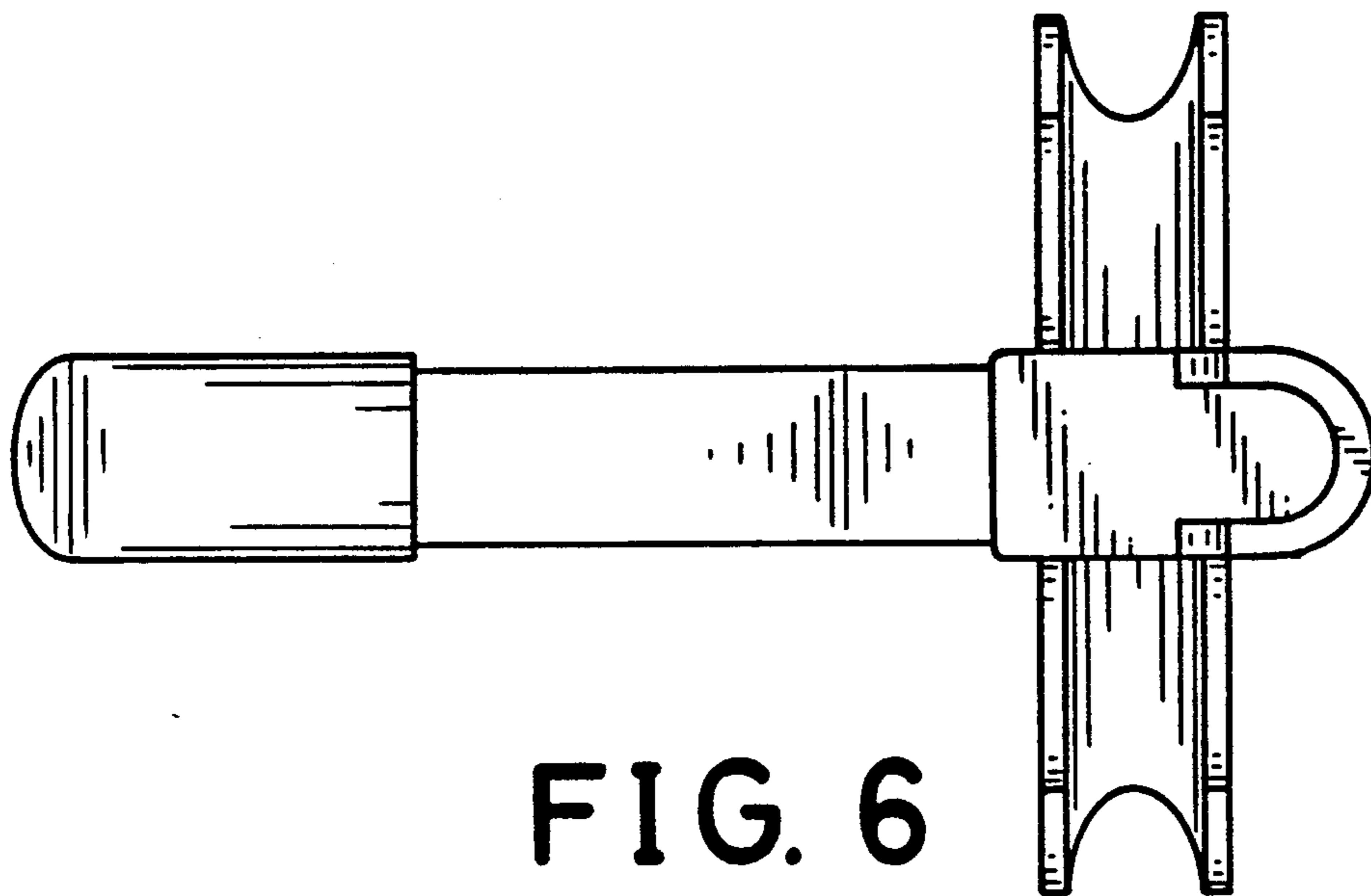

FIG. 6

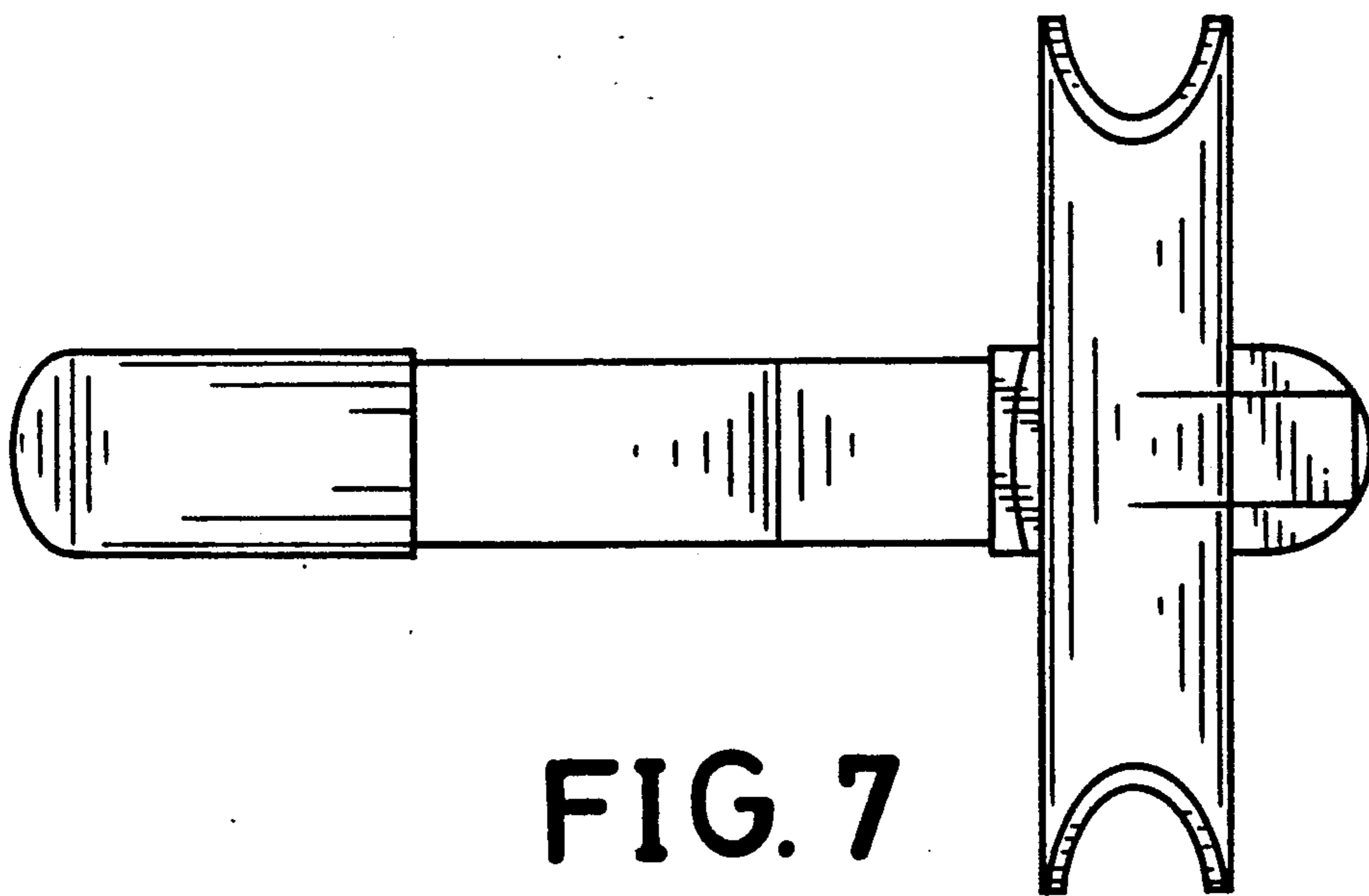

FIG. 7

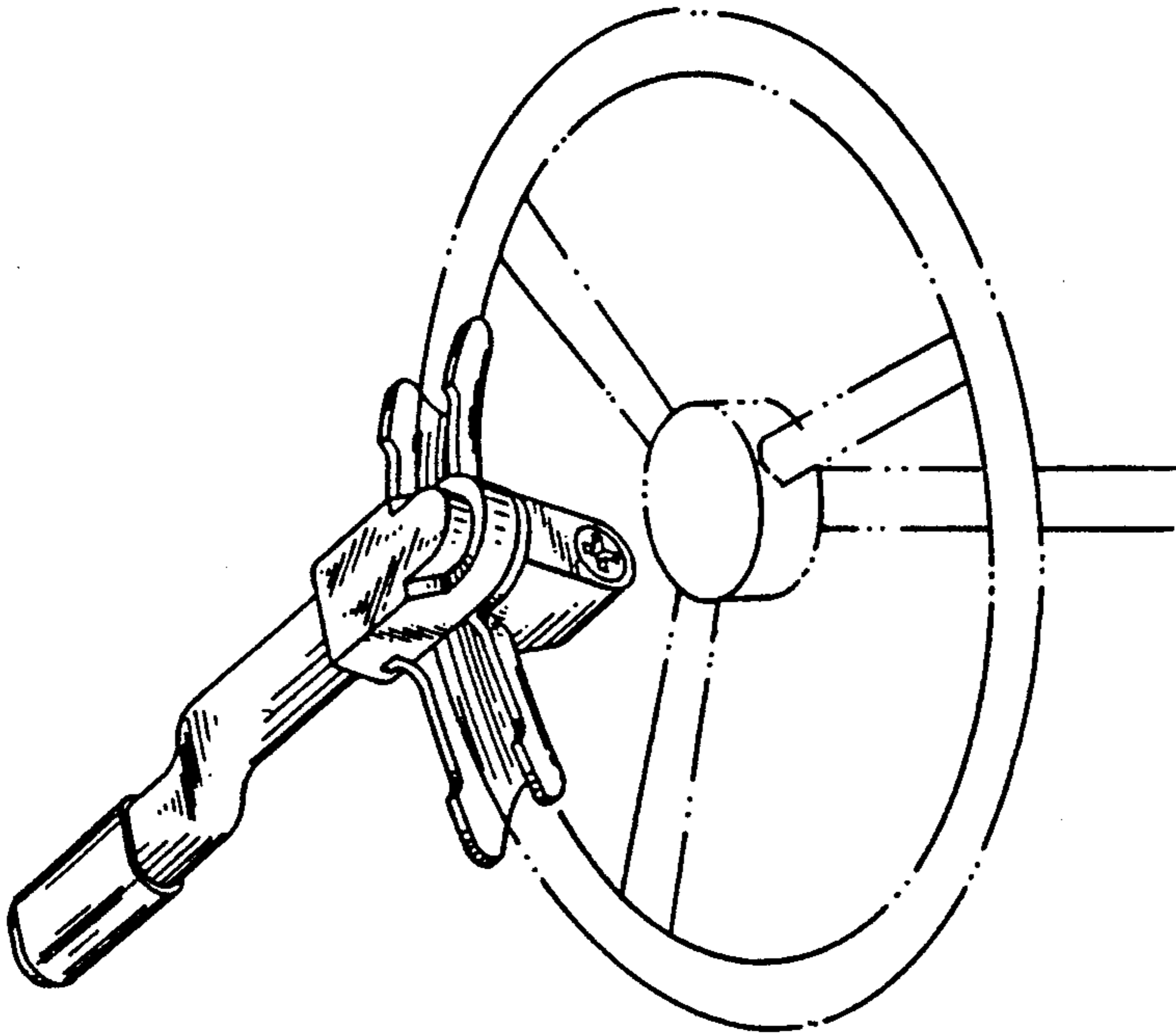

FIG. 8