



US00D330356S

# United States Patent [19]

[11] Patent Number: **Des. 330,356**

Tapio

[45] Date of Patent: **\*\* Oct. 20, 1992**

[54] **SHOCK ABSORBER AND STEERING UNIT FOR A SNOWMOBILE**

4,518,056	5/1985	Kobayashi	180/190
4,591,173	5/1986	Marier	180/190
4,826,260	5/1989	Plourde	180/193
5,029,664	7/1991	Zulowski	180/190

[75] Inventor: **Juhani Tapio, Rovaniemi, Finland**

[73] Assignee: **Nordtrac Oy, Finland, Finland**

[\*\*] Term: **14 Years**

*Primary Examiner—Wallace R. Burke  
Assistant Examiner—Melody Brown  
Attorney, Agent, or Firm—Steinberg & Raskin*

[21] Appl. No.: **599,907**

[57] **CLAIM**

[22] Filed: **Oct. 18, 1990**

The ornamental design for a shock absorber and steering unit for a snowmobile, as shown.

[30] **Foreign Application Priority Data**

**DESCRIPTION**

Apr. 19, 1990 [FI] Finland ..... 359/90

[52] U.S. Cl. .... **D12/159**

[58] Field of Search ..... D12/159, 114; 267/67, 267/68; 180/190-194

FIG. 1 is a top plan view of a shock absorber and steering unit for a snowmobile showing my new design; FIG. 2 is a top, front and left side perspective view thereof;

[56] **References Cited**

**U.S. PATENT DOCUMENTS**

D. 288,305	2/1987	Latchman	D12/114
4,098,523	7/1978	Valerio	267/67

FIG. 3 is a bottom plan view thereof; FIG. 4 is a top, rear and left side perspective view thereof; and

FIG. 5 is a bottom, front and right side perspective view thereof.

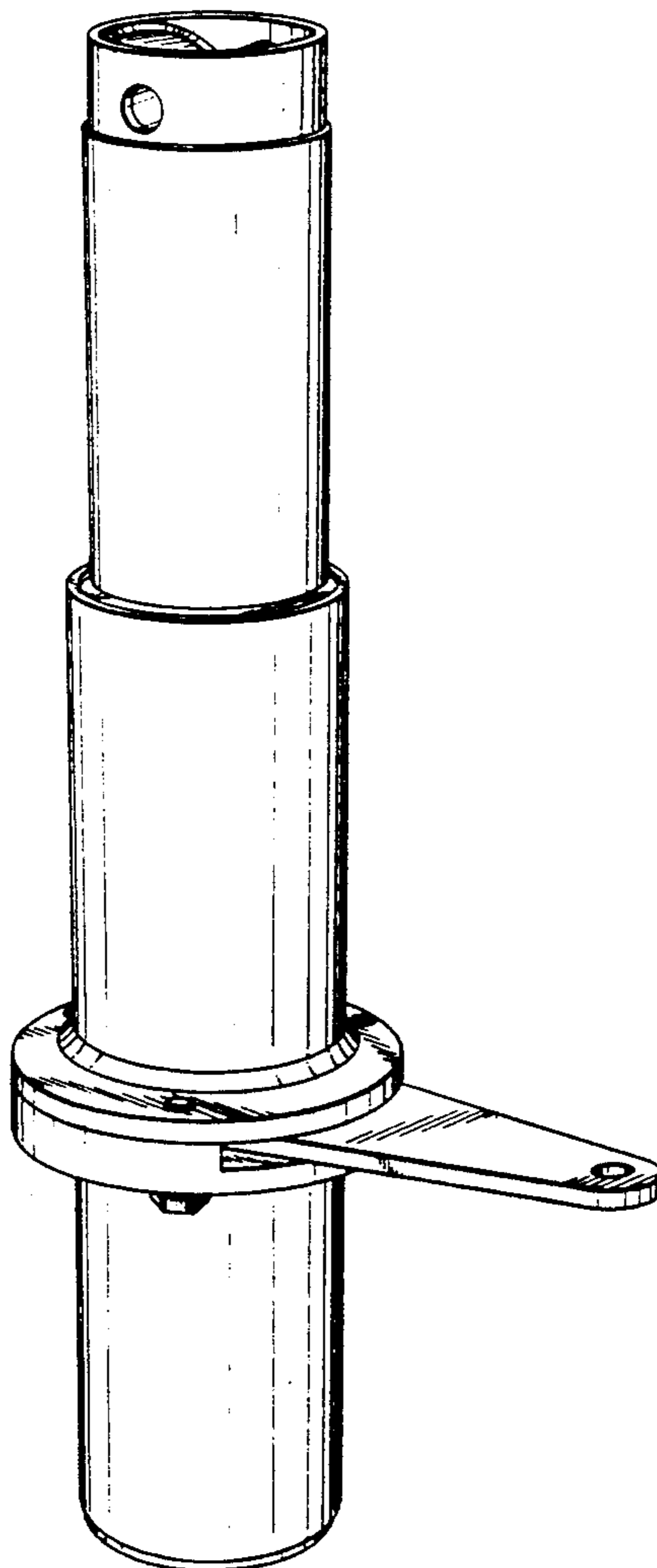

*FIG. 1*

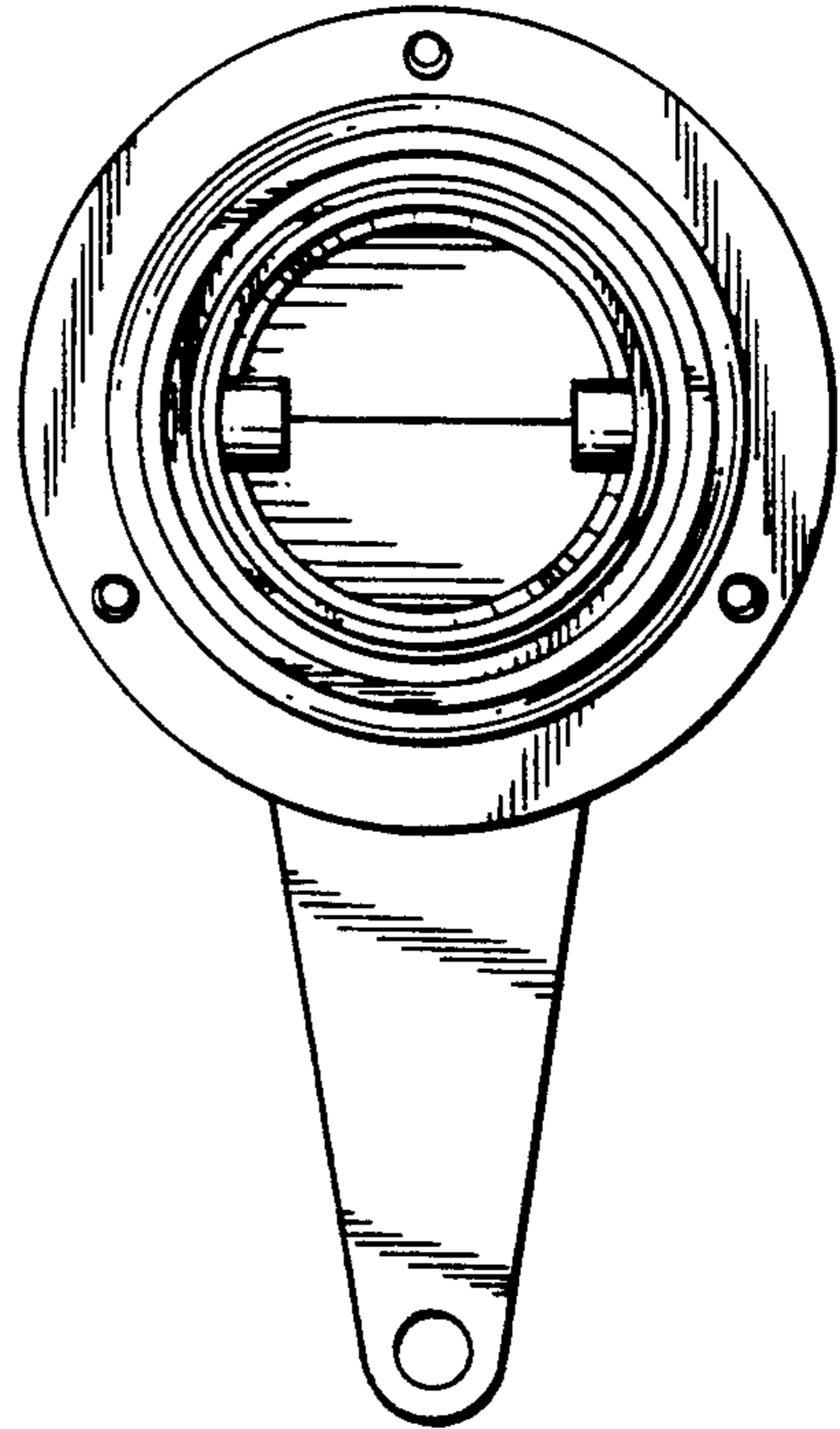

*FIG. 2*

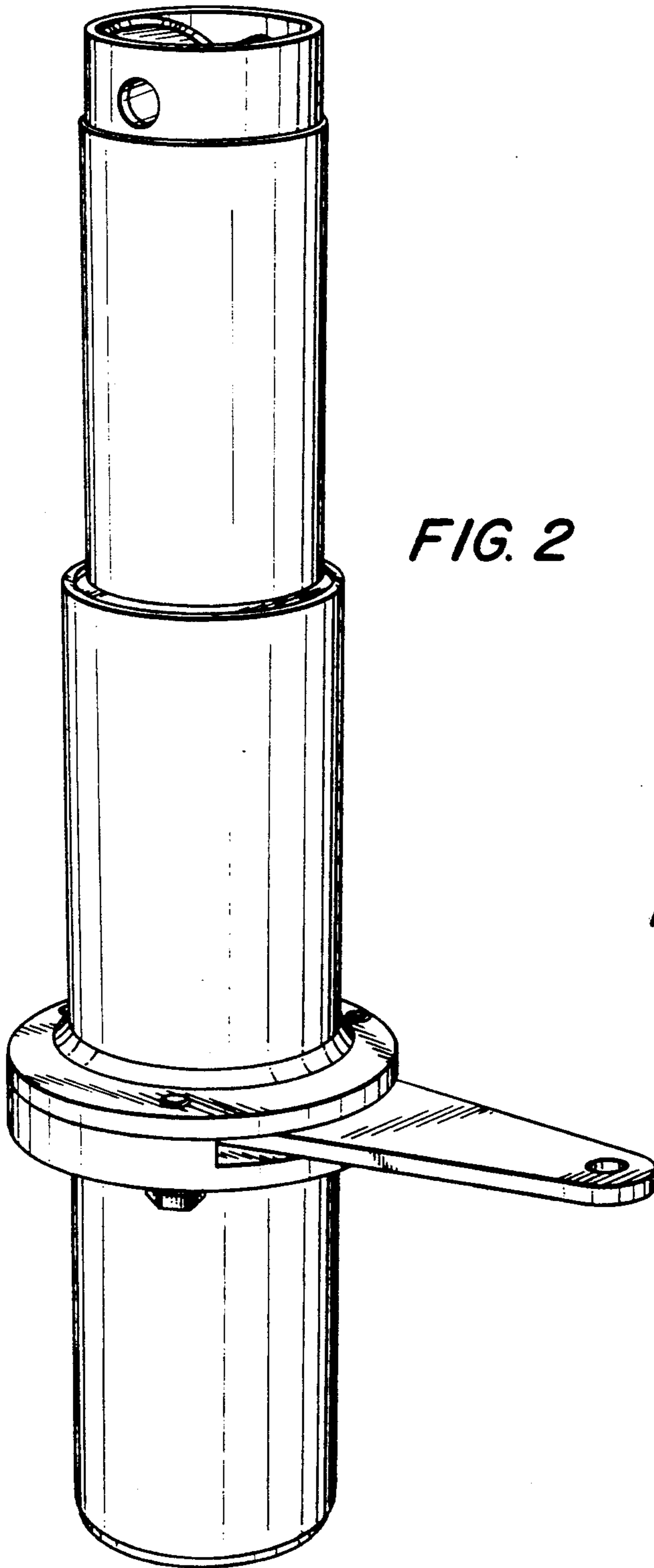

*FIG. 3*

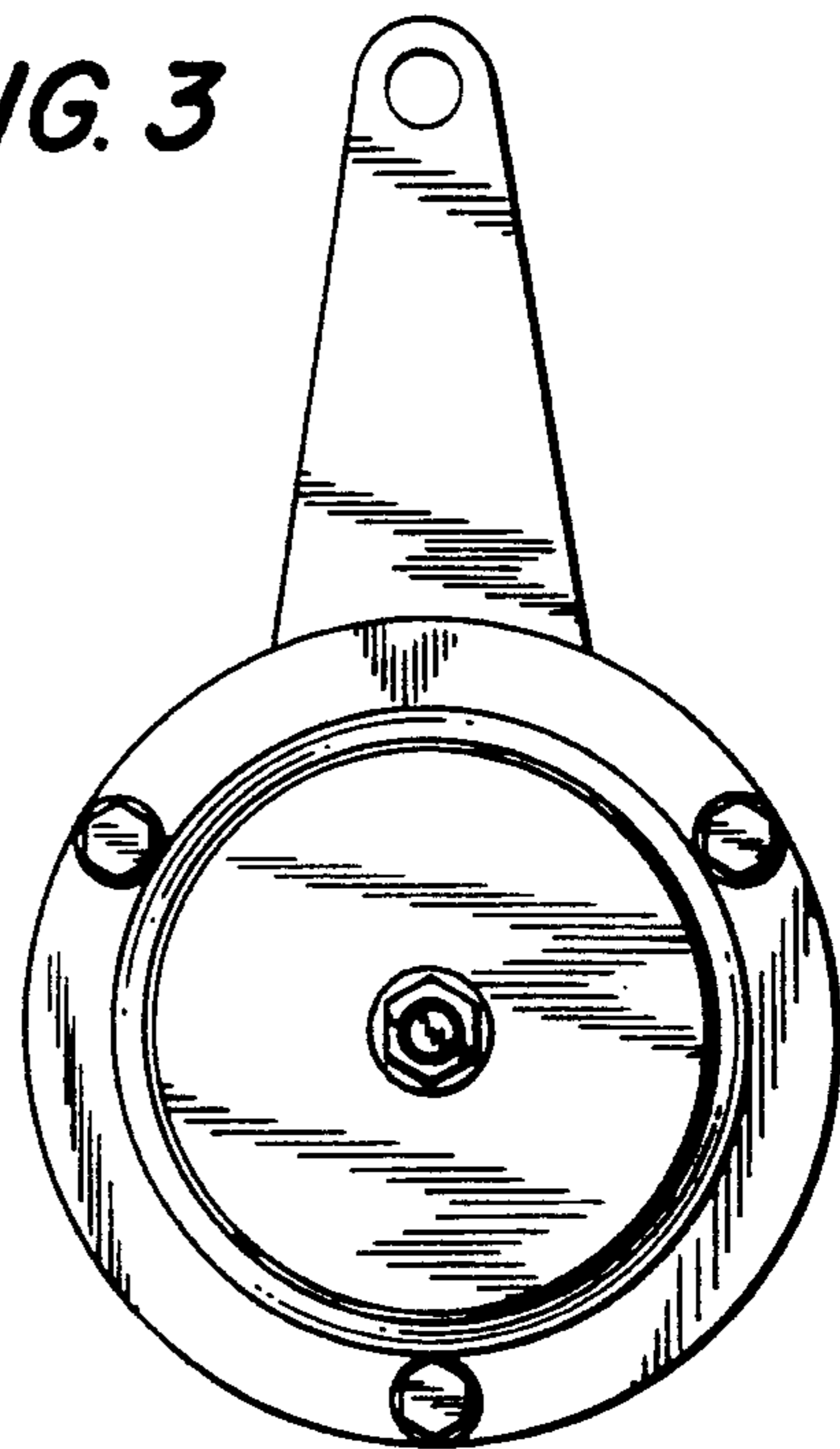

**FIG. 4**

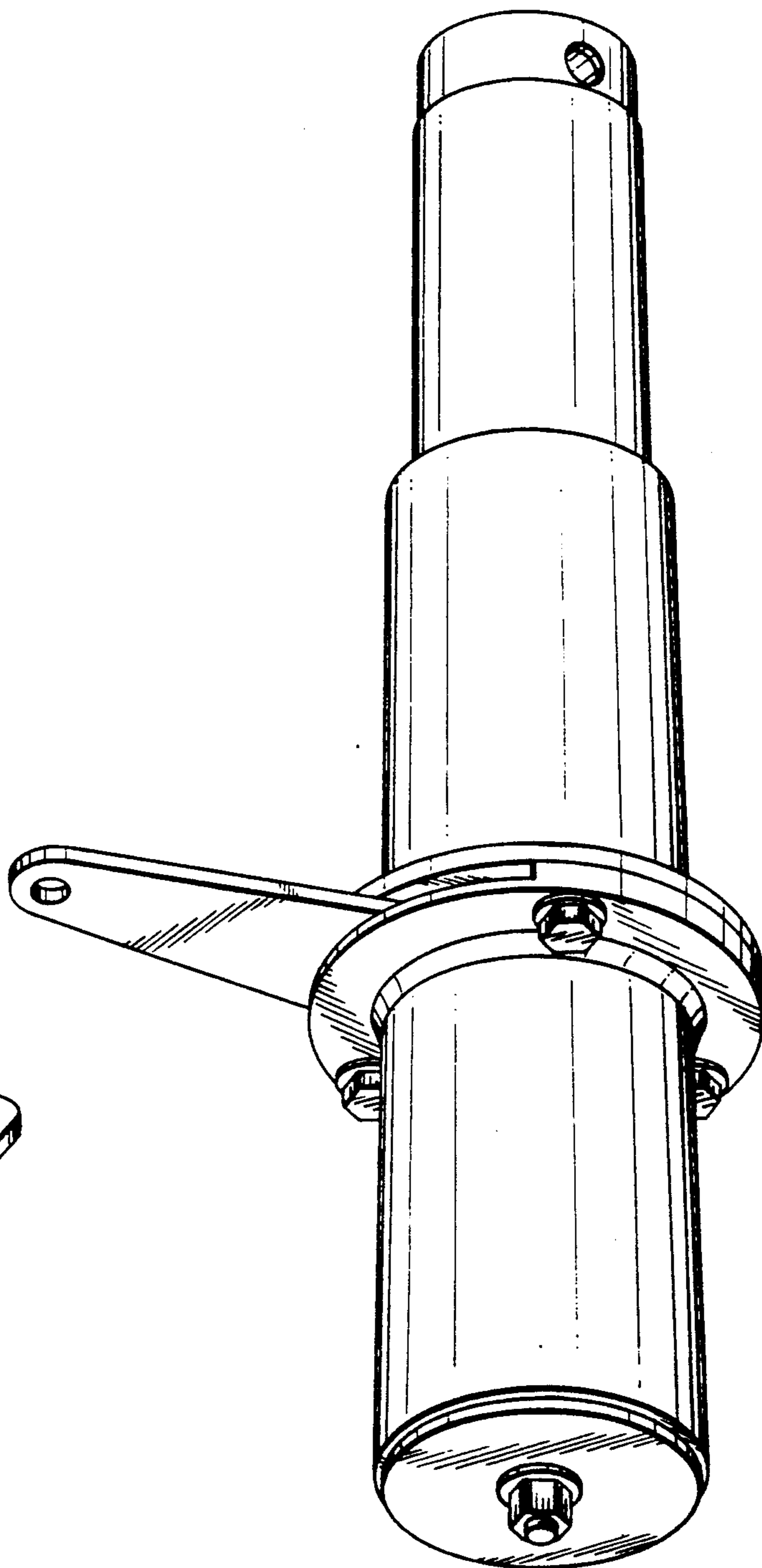
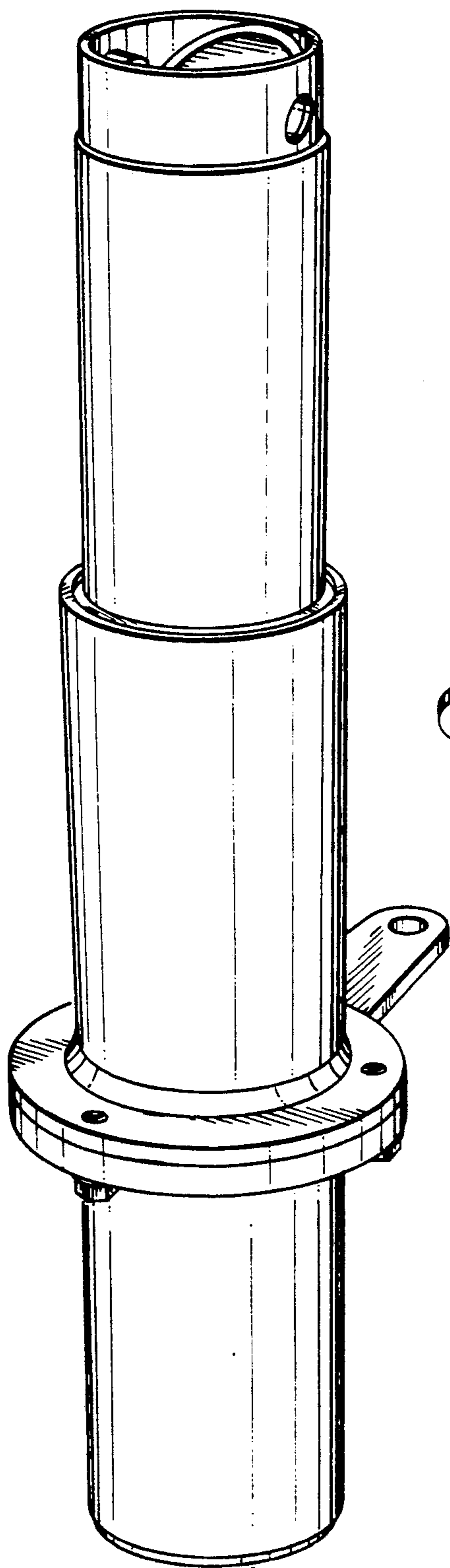

**FIG. 5**