



US00D330275S

United States Patent [19]

[11] Patent Number: Des. 330,275

West

[45] Date of Patent: ** Oct. 13, 1992

[54] GOLF CART

3,165,329	1/1965	Liibbe	280/DIG. 6
3,165,330	1/1965	Cotton .	
3,265,106	8/1966	Jarman .	
3,353,838	11/1967	Schmid .	
3,360,279	12/1967	Hunt .	
3,738,677	6/1973	Renock .	
3,883,150	5/1975	Varela .	
4,126,327	11/1978	Taber	280/DIG. 6

[76] Inventor: Fred O. West, 2520 Andover Pl.,
Costa Mesa, Calif. 92626

[**] Term: 14 Years

[21] Appl. No.: 504,237

[22] Filed: Apr. 4, 1990

[52] U.S. Cl. D34/15; D34/26

[58] Field of Search D34/15, 12, 26, 24;
280/47.19, DIG. 6, 47.2, 47.26, 47.35, 37

Primary Examiner—Kay H. Chin

Attorney, Agent, or Firm—Knobbe, Martens, Olson &
Bear

[56] References Cited

U.S. PATENT DOCUMENTS

1,951,492	3/1934	Schneider .
2,513,055	6/1950	Samuelson .
2,551,009	5/1951	Kaltenbach .
2,571,392	10/1951	Stringer .
2,662,776	12/1953	Hurst .
2,679,876	6/1954	Schall .
2,681,232	6/1954	Womack .
2,681,810	6/1954	Lowinski .
2,732,218	1/1956	Resch .
2,757,012	7/1956	Leffler .
2,761,691	9/1956	George .
2,841,408	7/1958	Mariotte .
2,857,168	10/1958	Neaverson et al. .
2,921,797	1/1960	Berglund et al. .
2,950,748	8/1960	Olinghouse .
2,992,012	7/1961	Herold .
3,081,108	3/1963	Vogt .
3,164,393	1/1965	Upham .

[57] CLAIM

The ornamental design for a golf cart, as shown and described.

DESCRIPTION

FIG. 1 is a front perspective view of a golf cart showing my new design;
 FIG. 2 is a front elevational view thereof;
 FIG. 3 is a left-side elevational view thereof;
 FIG. 4 is a rear elevational view thereof;
 FIG. 5 is a right-side elevational view thereof;
 FIG. 6 is a top plan view thereof;
 FIG. 7 is a bottom plan view thereof;
 FIG. 8 is a left side elevational view thereof in its transition to a folded condition;
 FIG. 9 is a left side elevational view thereof in a folded condition; and,
 FIG. 10 is a front perspective view thereof, the broken lines are for illustrative purposes only and form no part of the claimed design.

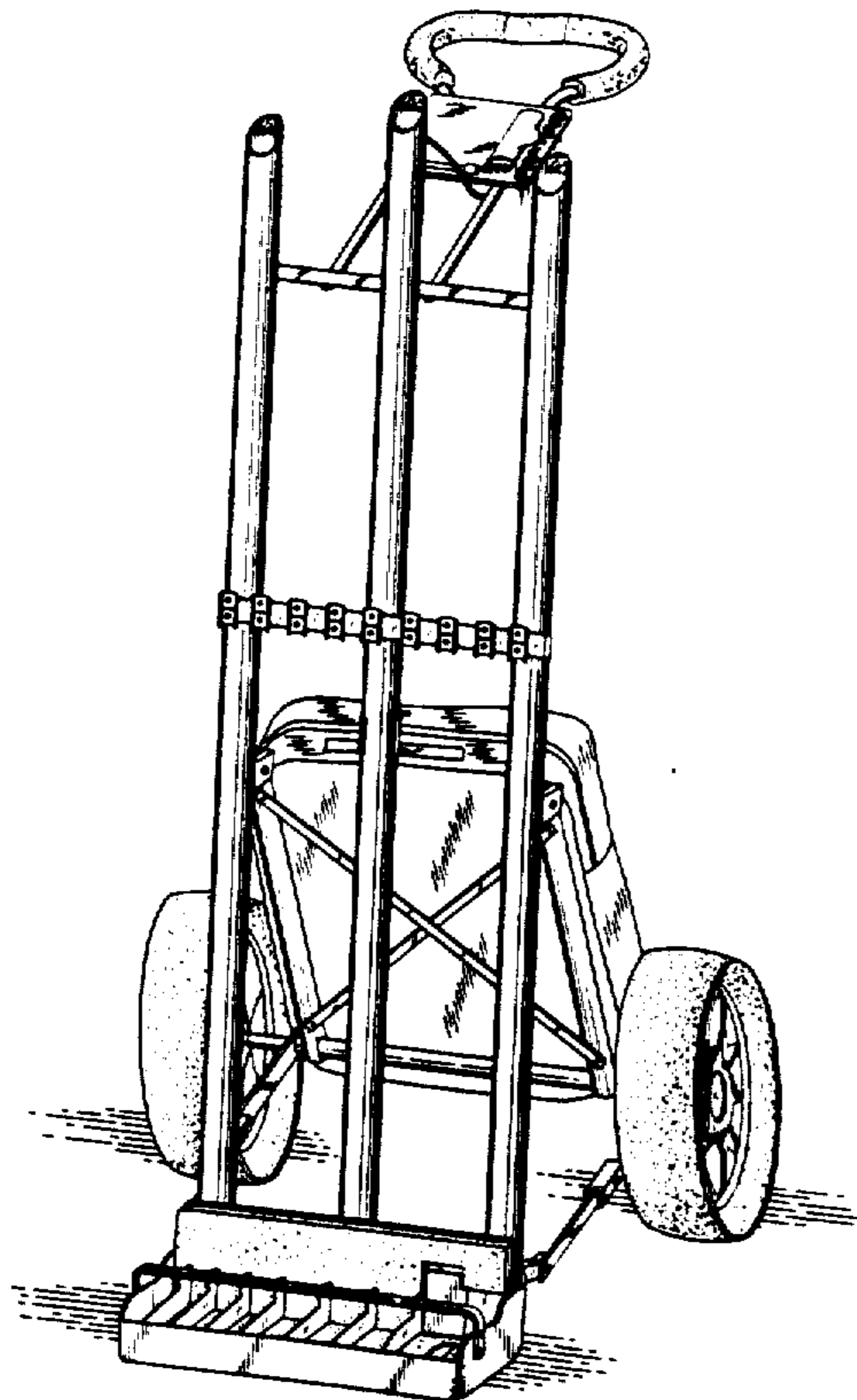
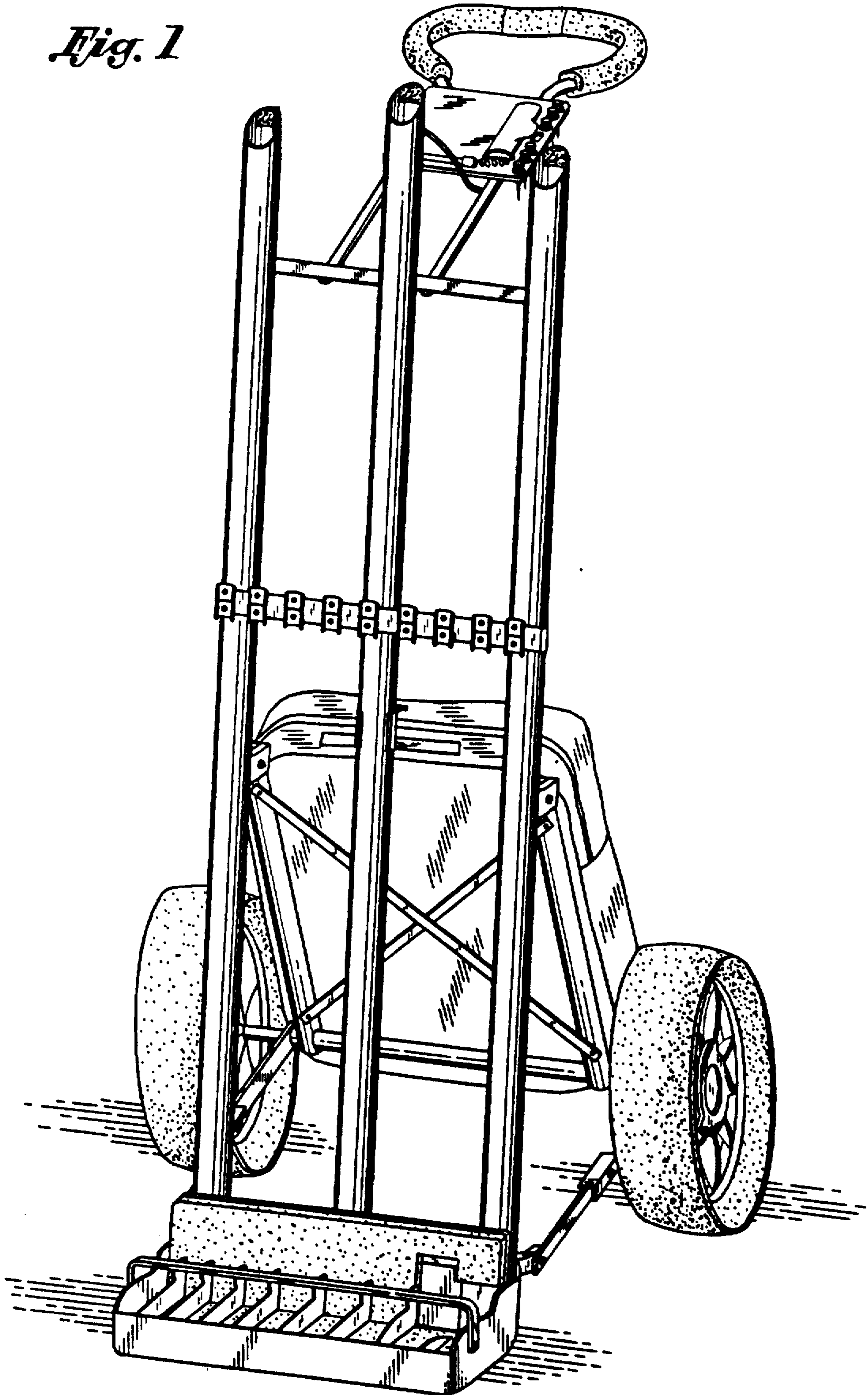

Fig. 1



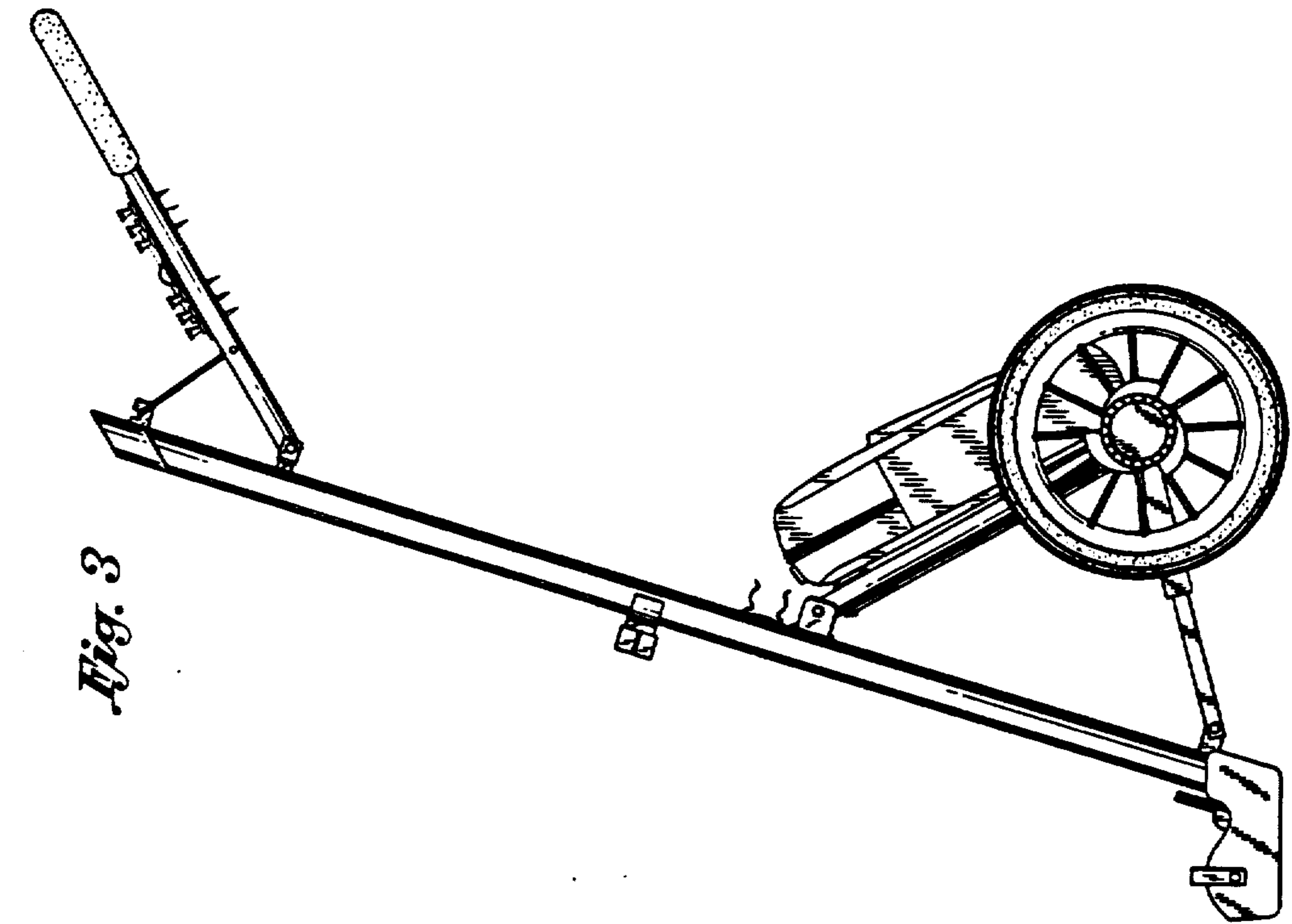

Fig. 3

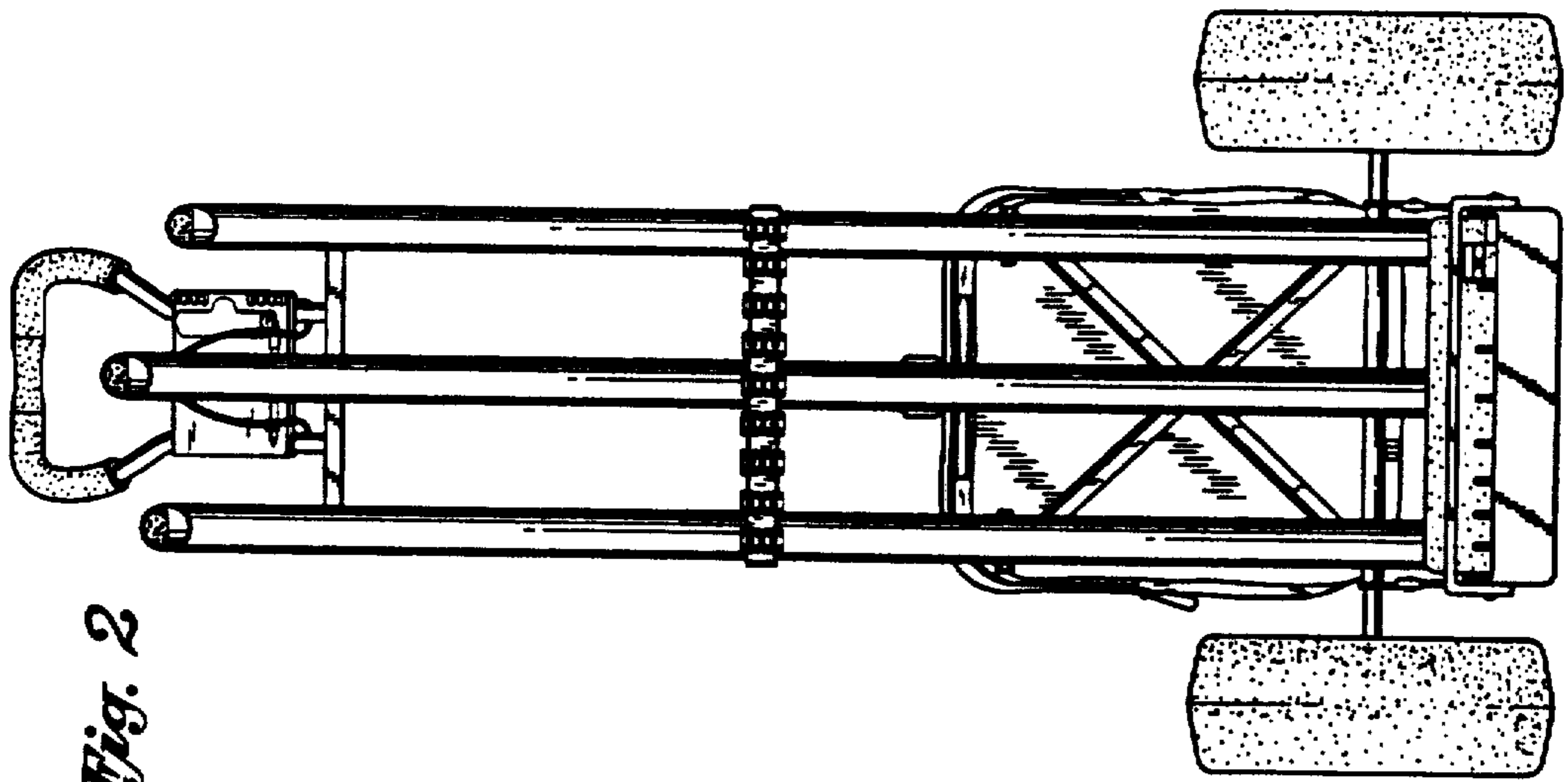

Fig. 2

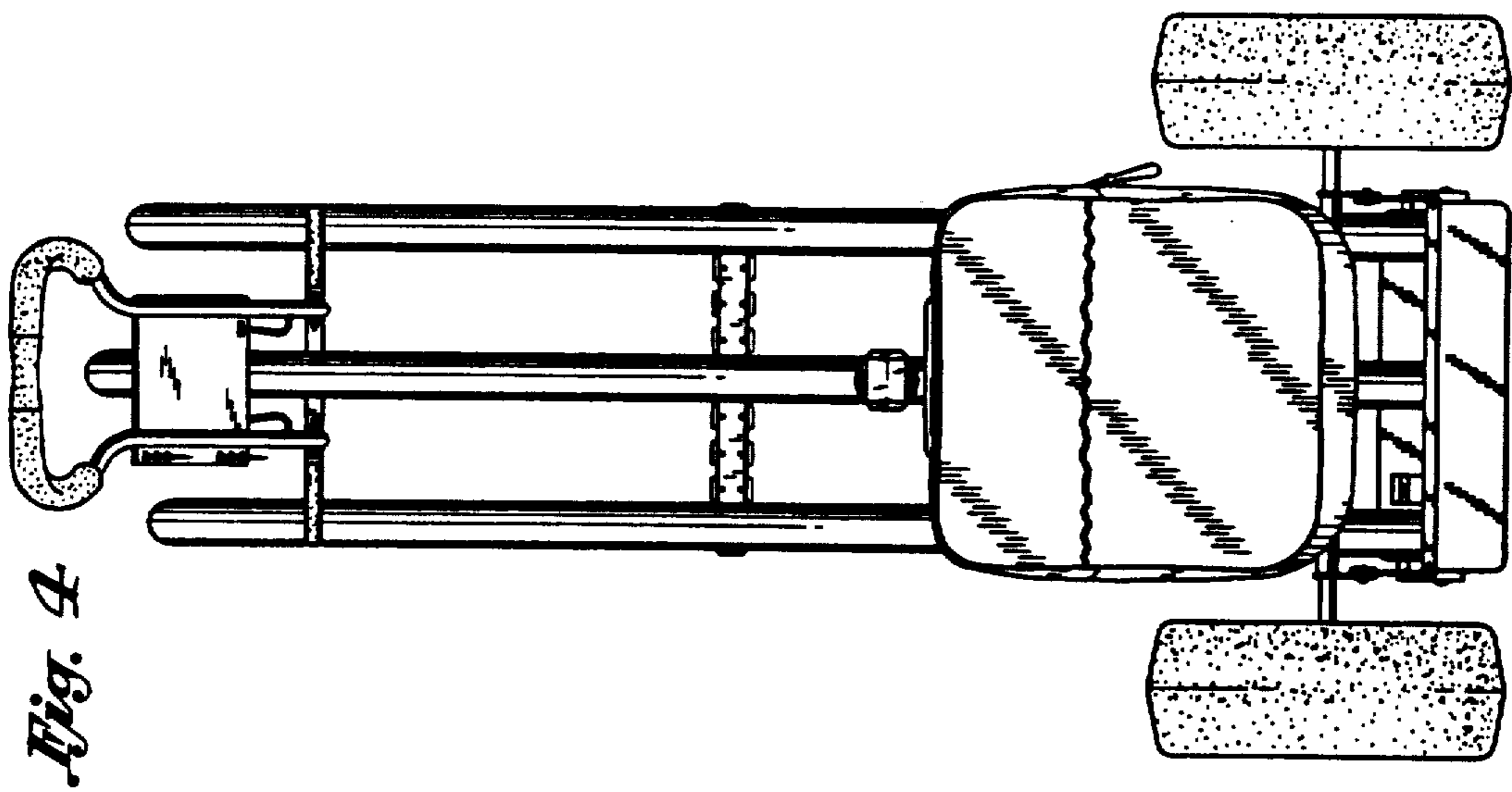
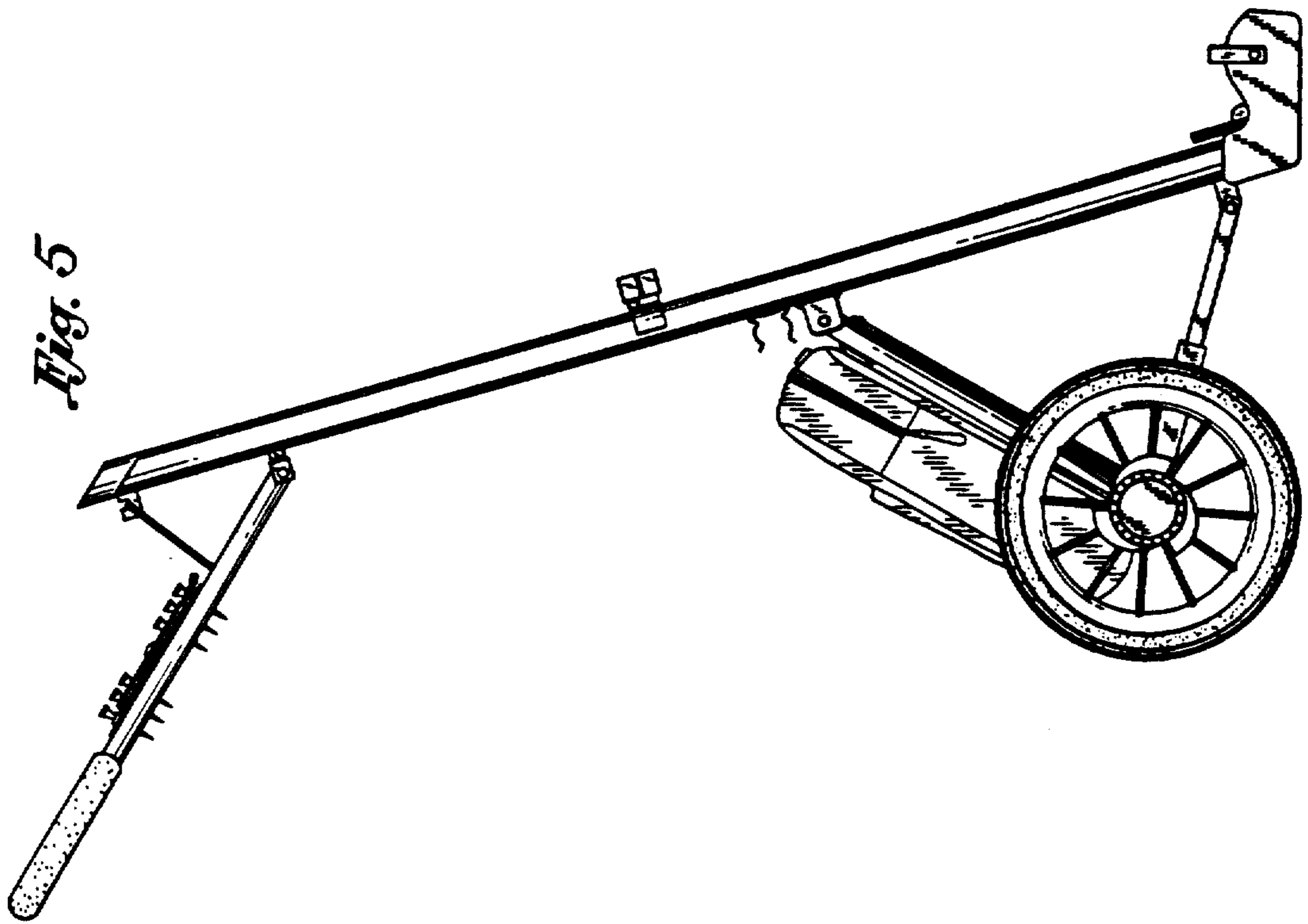

Fig. 6

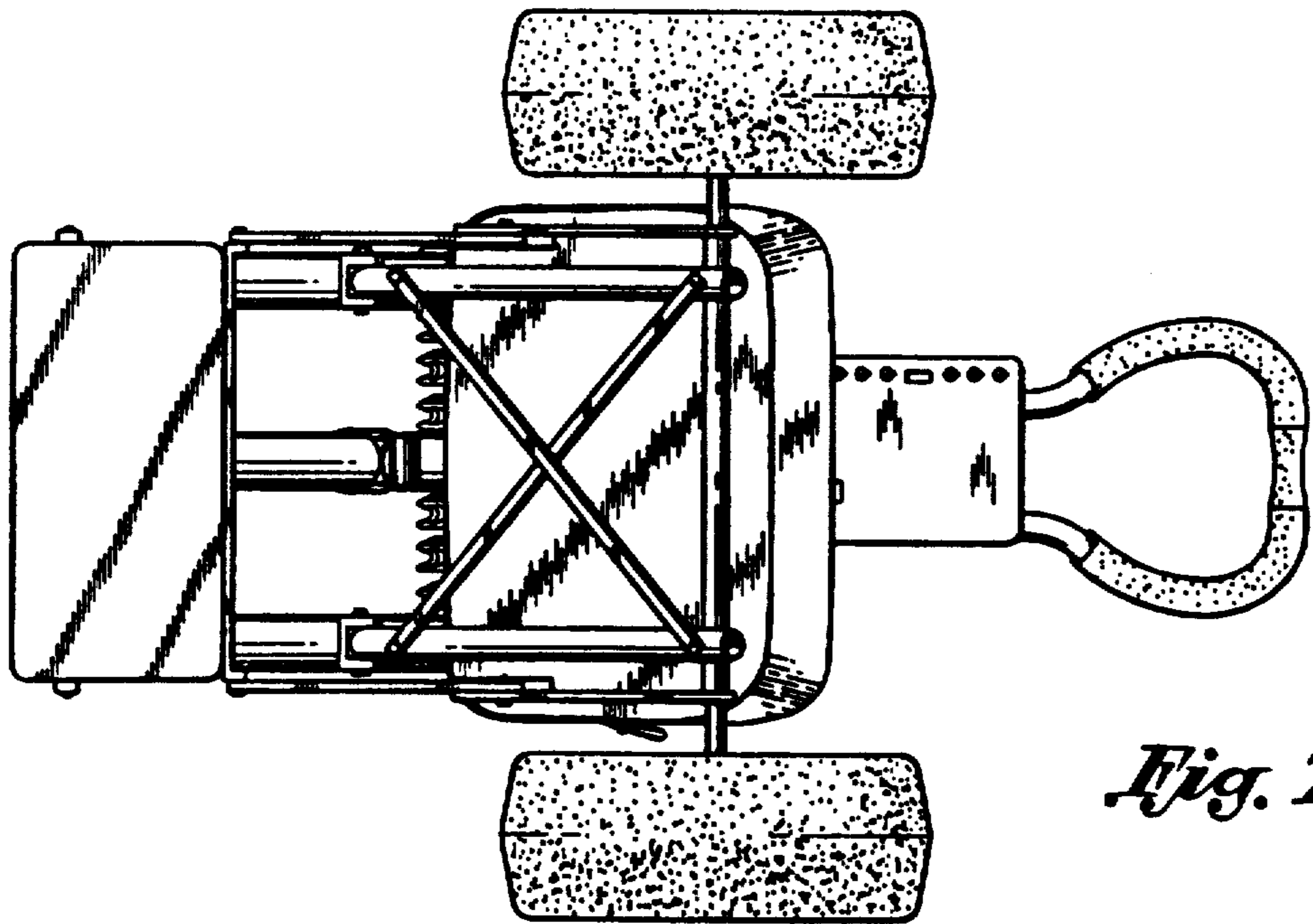
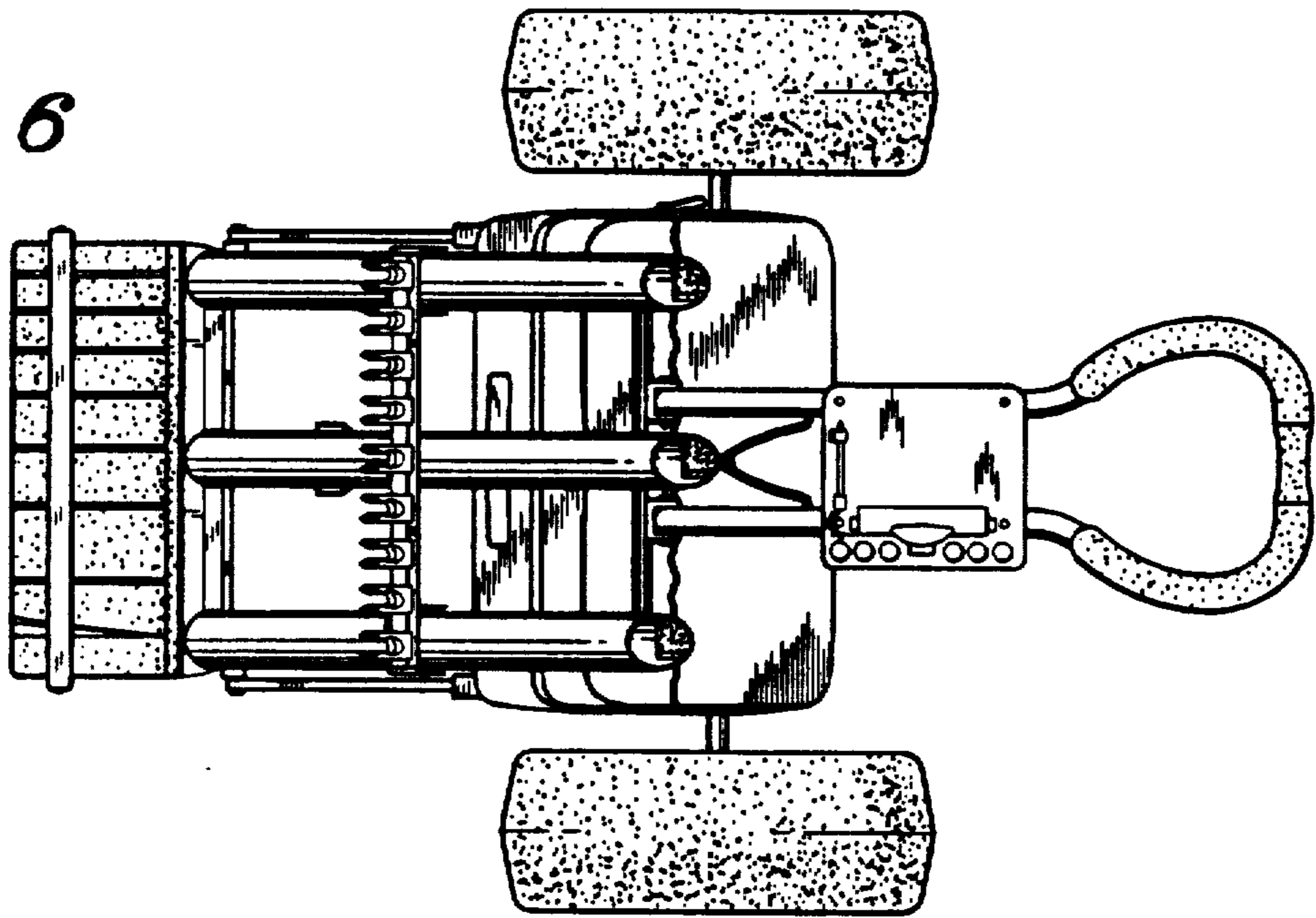

Fig. 7

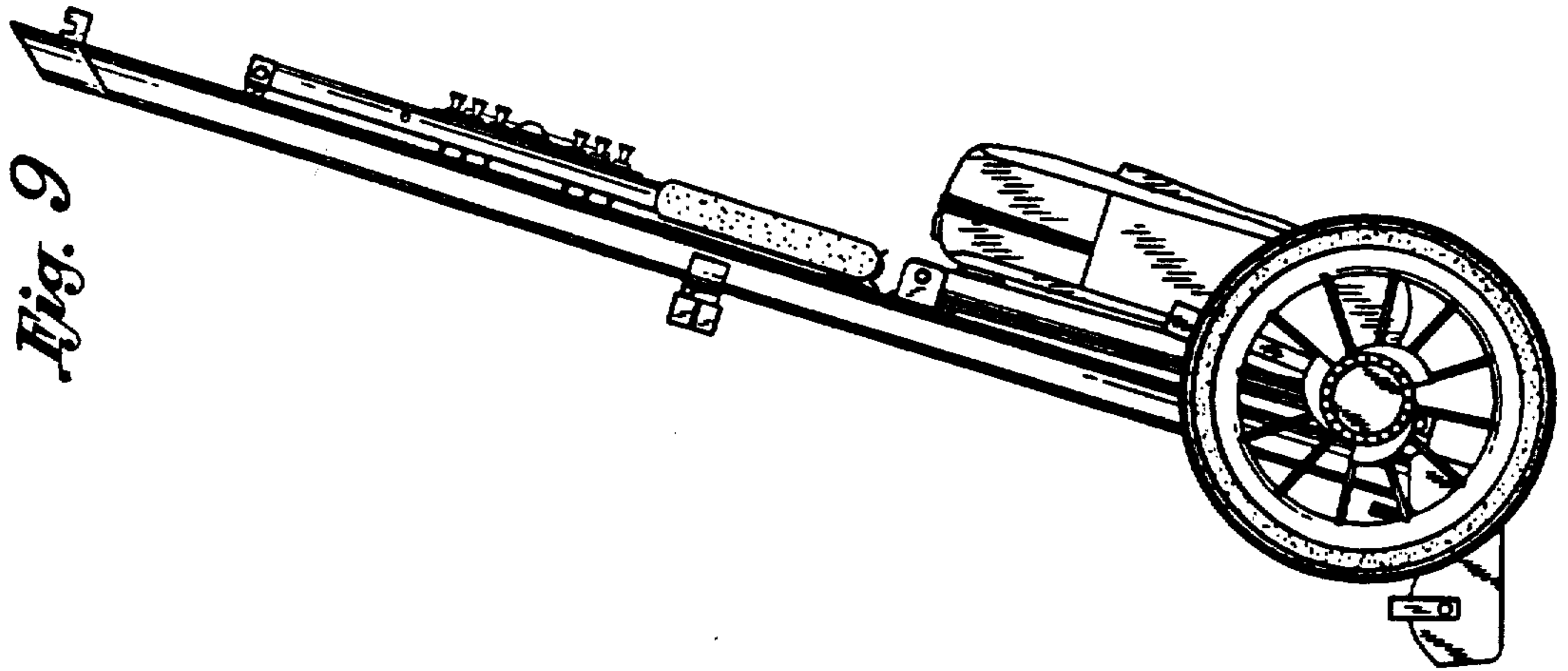

Fig. 9

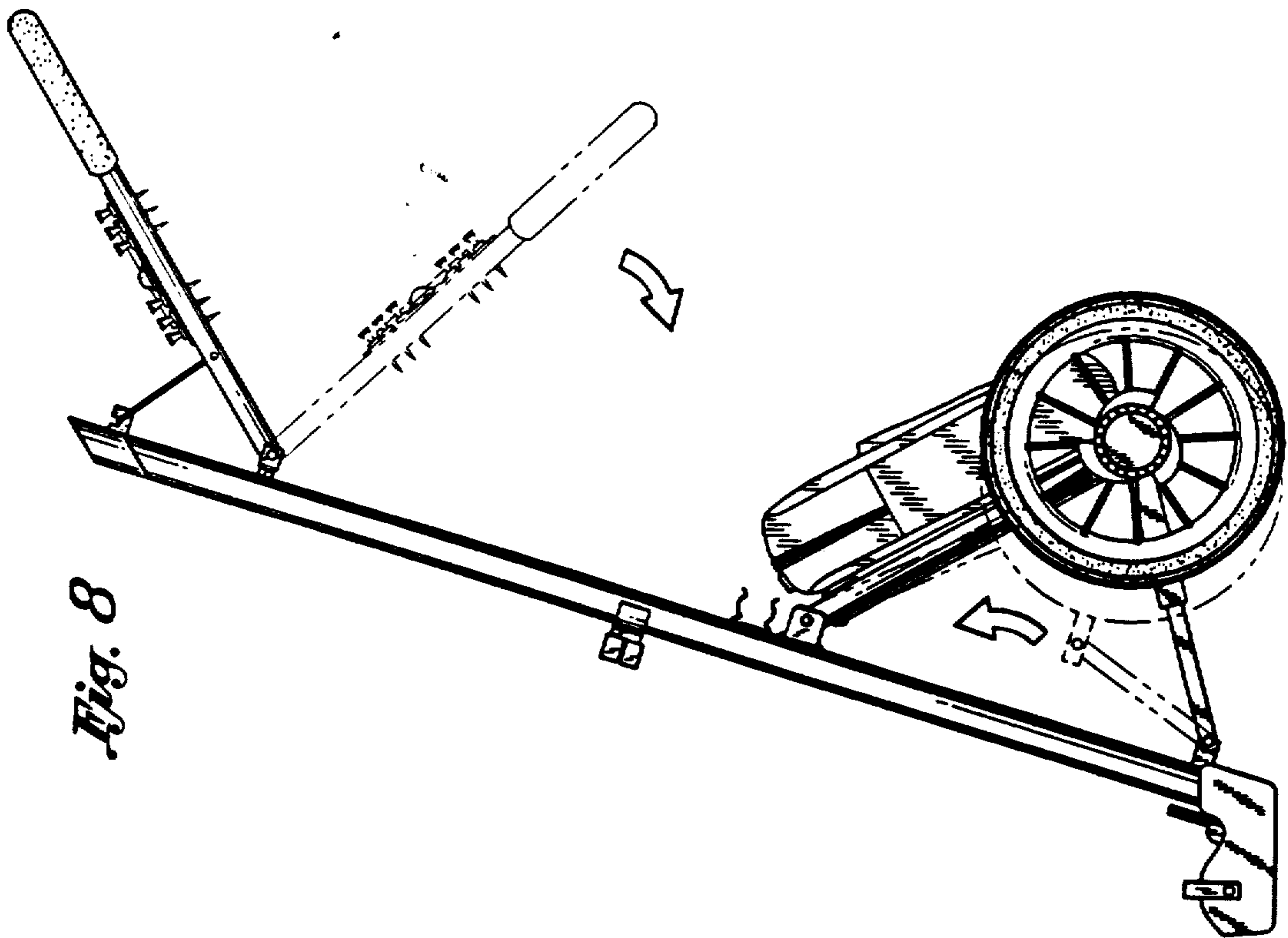

Fig. 8

Fig. 10

