



US00D330007S

United States Patent [19]

[11] Patent Number: **Des. 330,007**

Francis

[45] Date of Patent: **** Oct. 6, 1992**

[54] **WIRING PANEL FOR ATTACHMENT TO MOTOR VEHICLE ENGINES**

3,393,350	7/1968	Groudy et al.	361/346
3,960,353	6/1976	Leutwyler	361/358 X
4,642,888	2/1987	Love	361/346 X
4,942,499	7/1999	Shibata et al.	439/34 X

[76] Inventor: **Ron Francis, 167 Keystone Rd., Chester, Pa. 19013**

Primary Examiner—Susan J. Lucas
Assistant Examiner—M. H. Tung
Attorney, Agent, or Firm—Lipton & Famiglio

[**] Term: **14 Years**

[21] Appl. No.: **334,226**

[57] **CLAIM**

[22] Filed: **Apr. 6, 1989**

The ornamental design for a wiring panel for attachment to motor vehicle engines, as shown.

[52] U.S. Cl. **D13/126; D13/162**

[58] Field of Search **D13/126, 162, 158, 164, D13/177, 147; 361/51, 332-335, 346, 356-360, 380, 390-395; 439/34, 130, 357, 449-450, 540, 638-639, 721, 856**

DESCRIPTION

FIG. 1 is a top plan view of a wiring panel for attachment to automobile engines showing my new design; FIG. 2 is a left side elevational view thereof; FIG. 3 is a rear elevational view thereof; FIG. 4 is a front elevational view thereof; FIG. 5 is a bottom plan view thereof; and, FIG. 6 is a top perspective view thereof.

[56] **References Cited**

U.S. PATENT DOCUMENTS

D. 318,852 8/1991 Matsumoto et al. D13/147

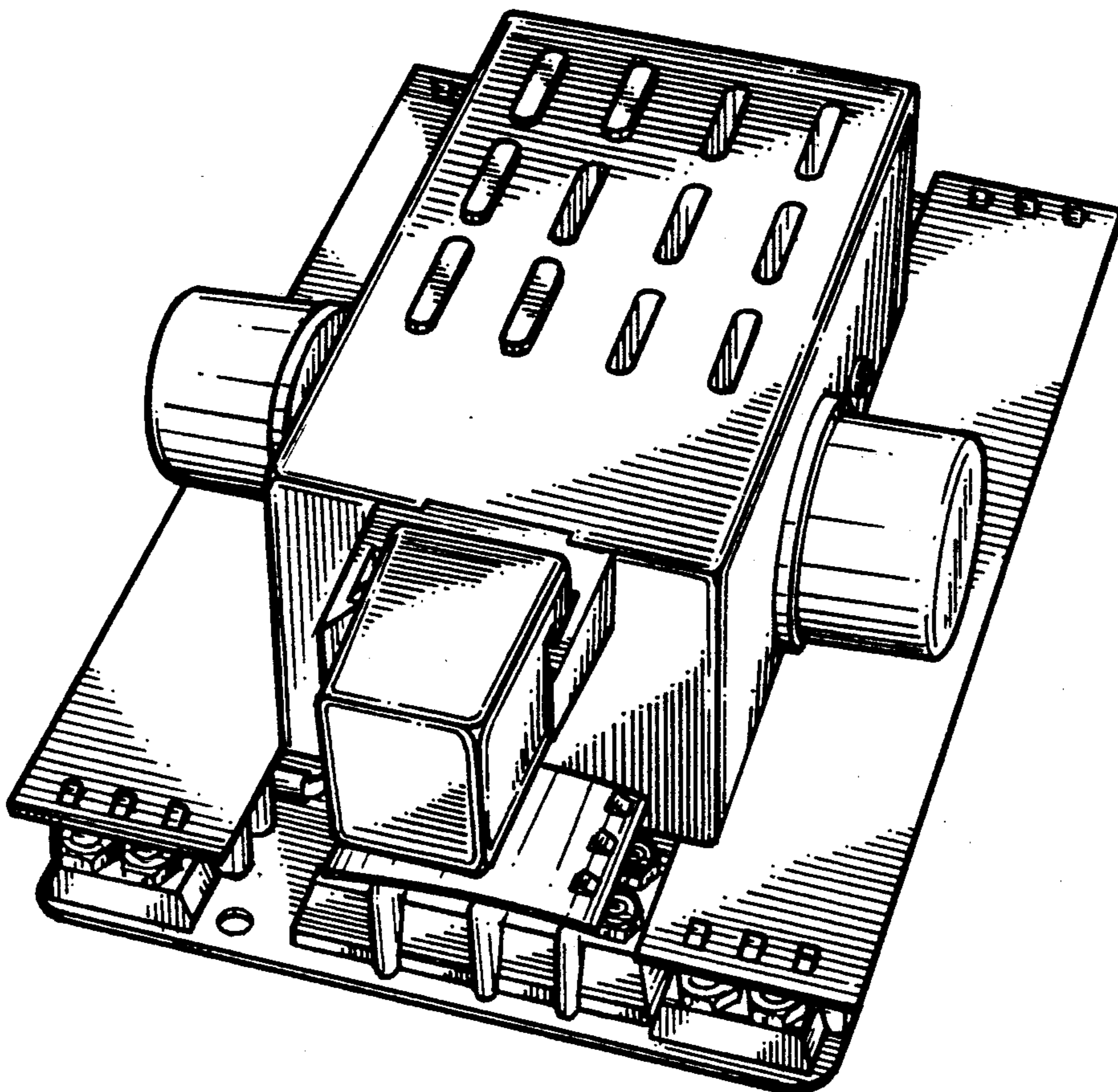

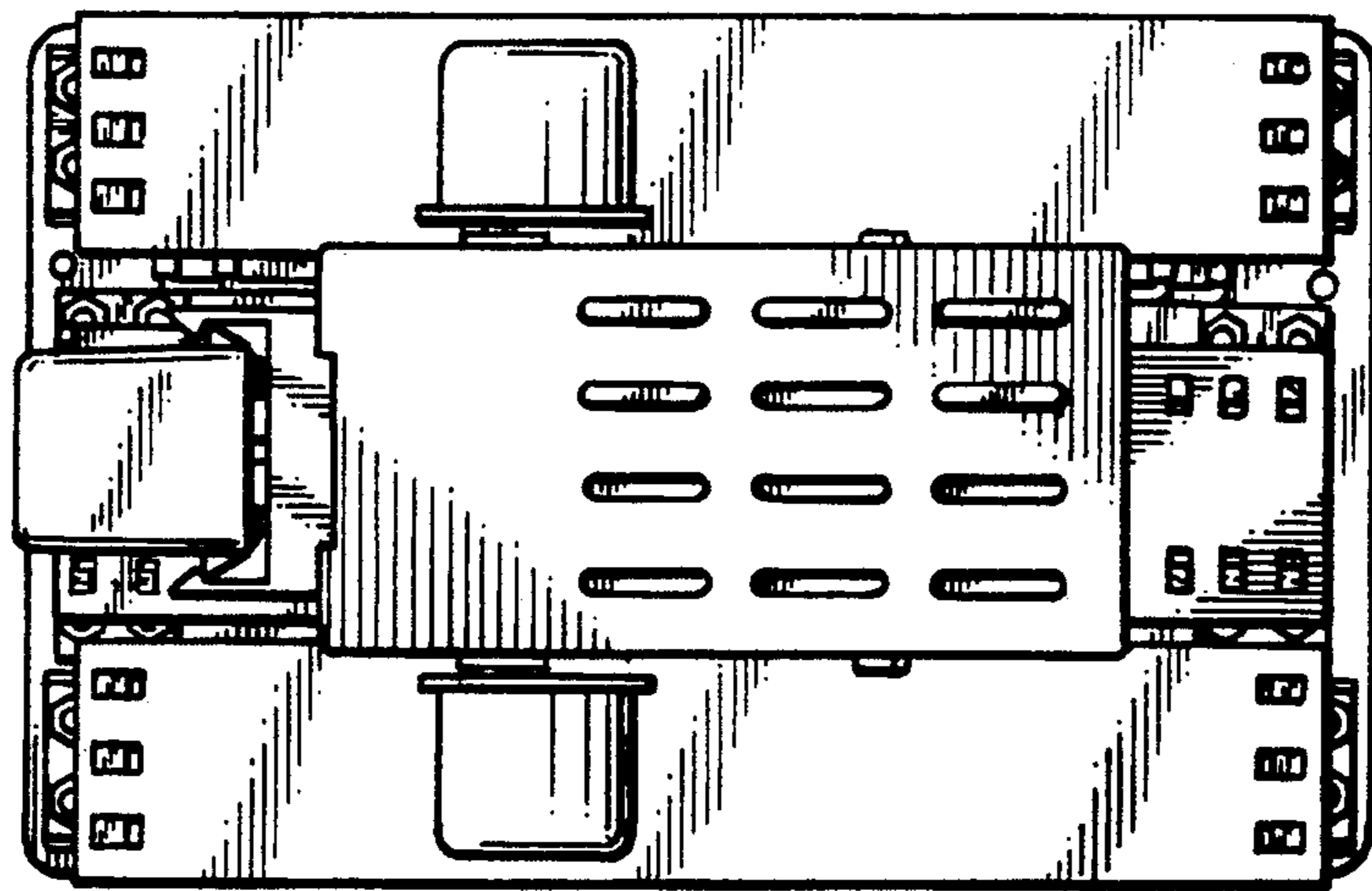

FIG. 1

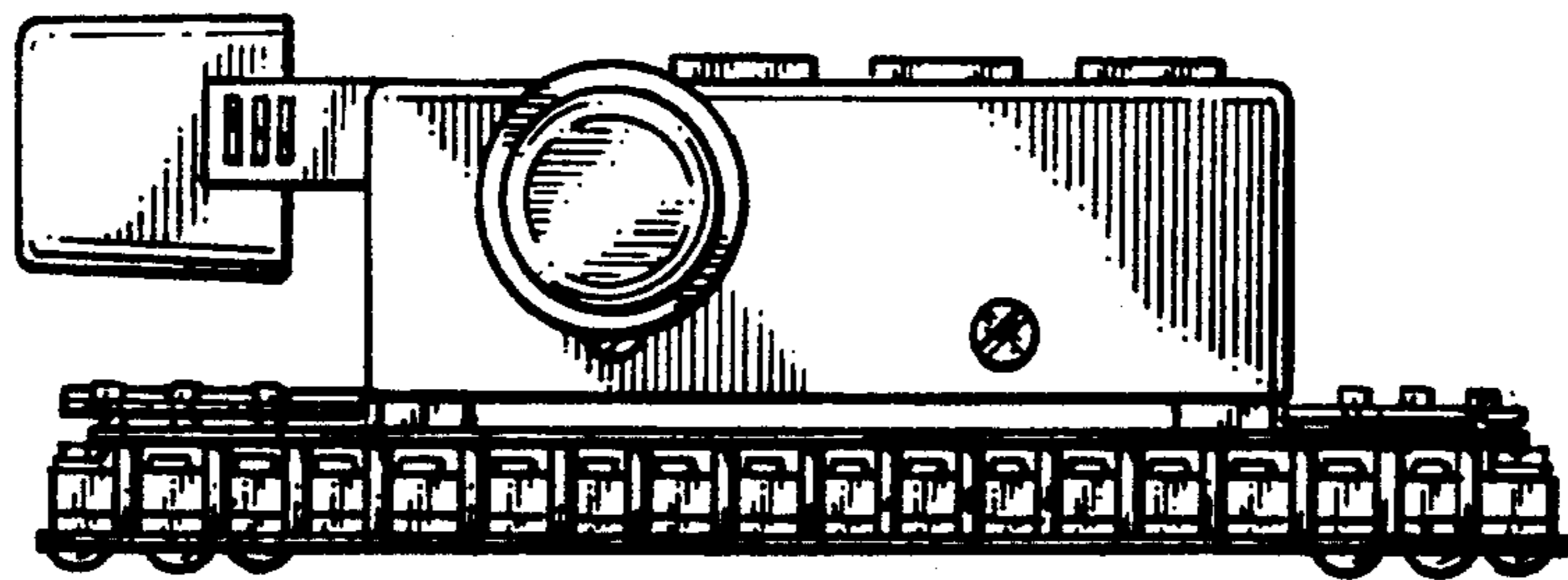

FIG. 2

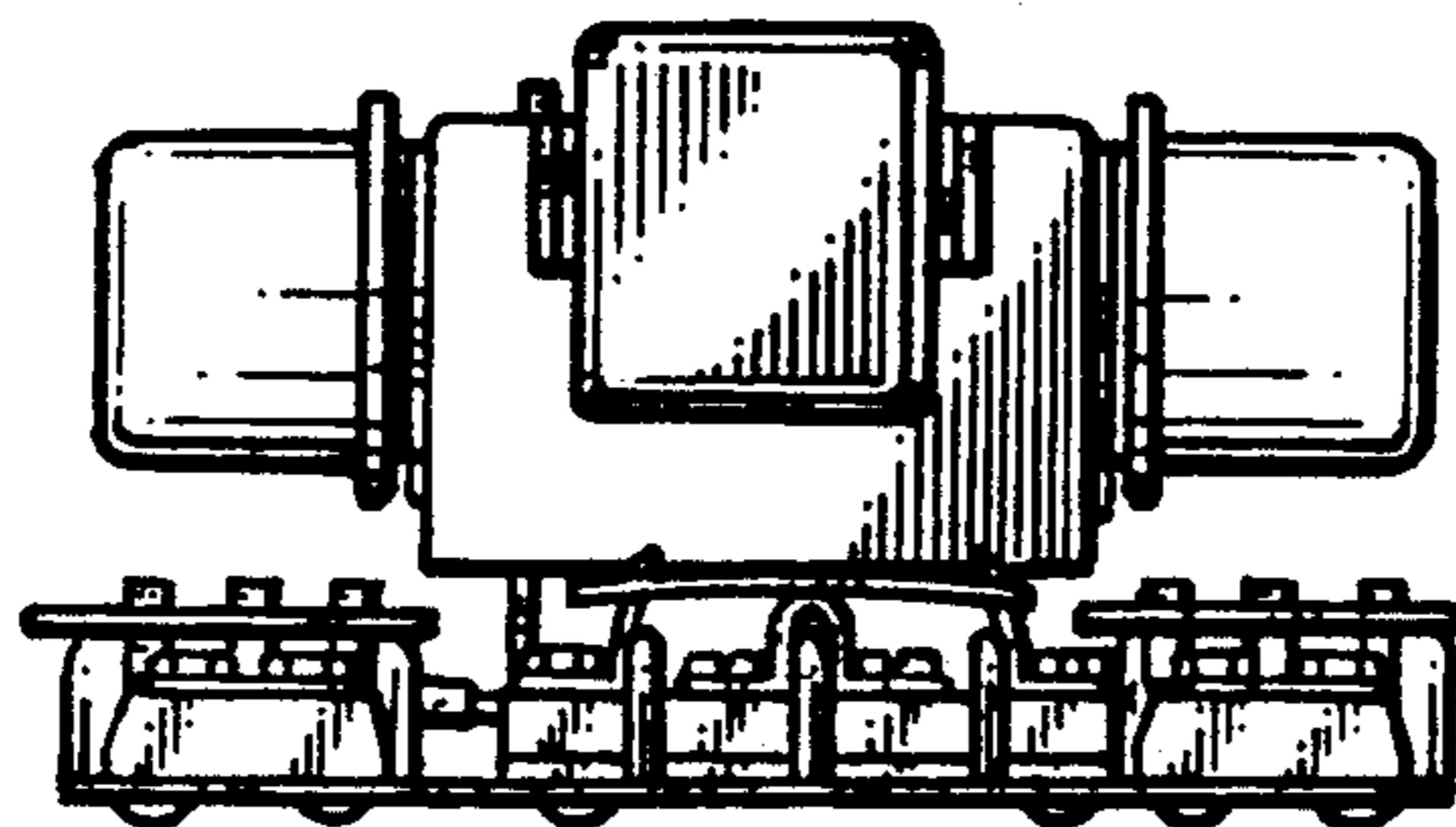

FIG. 3

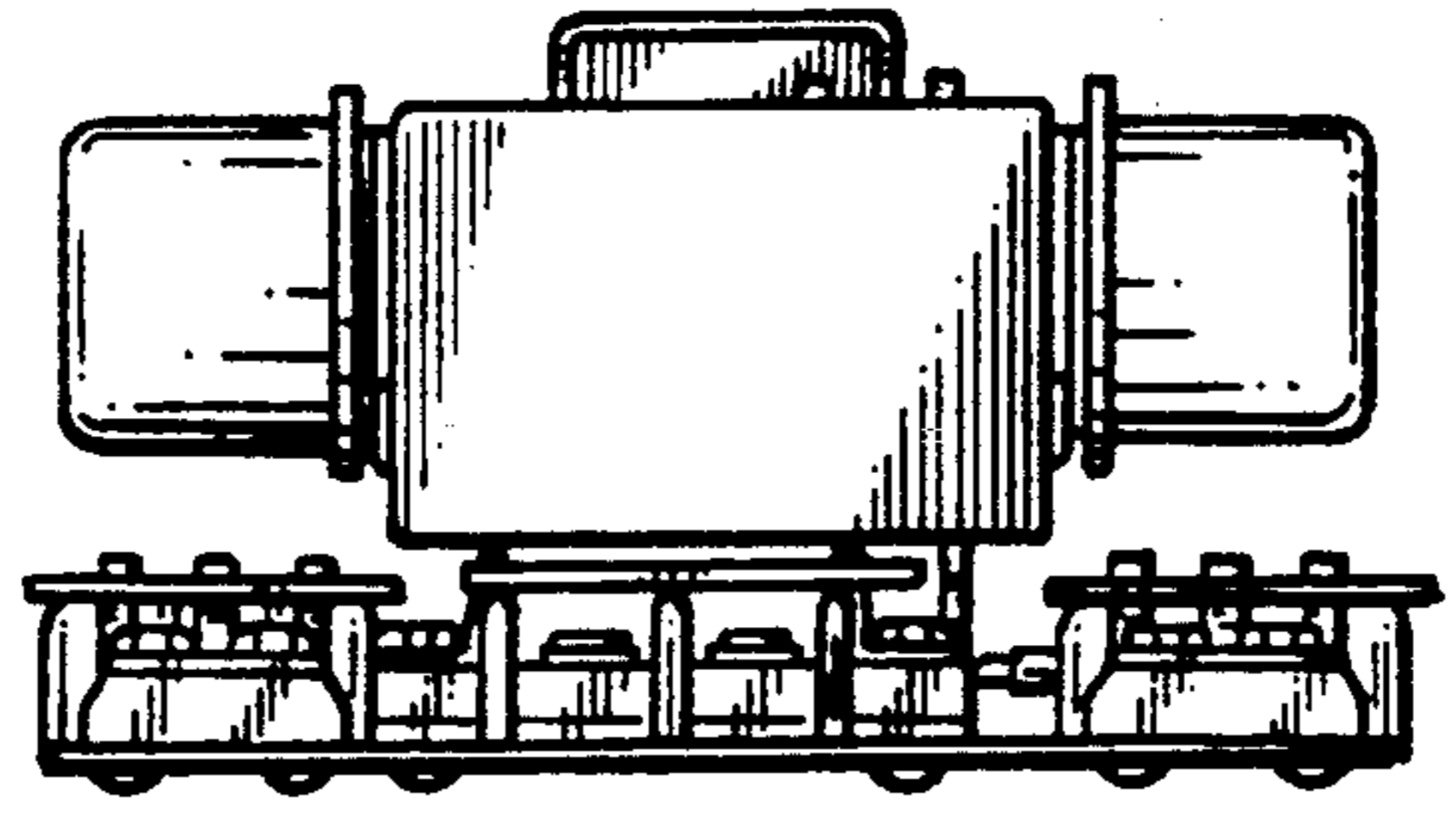

FIG. 4

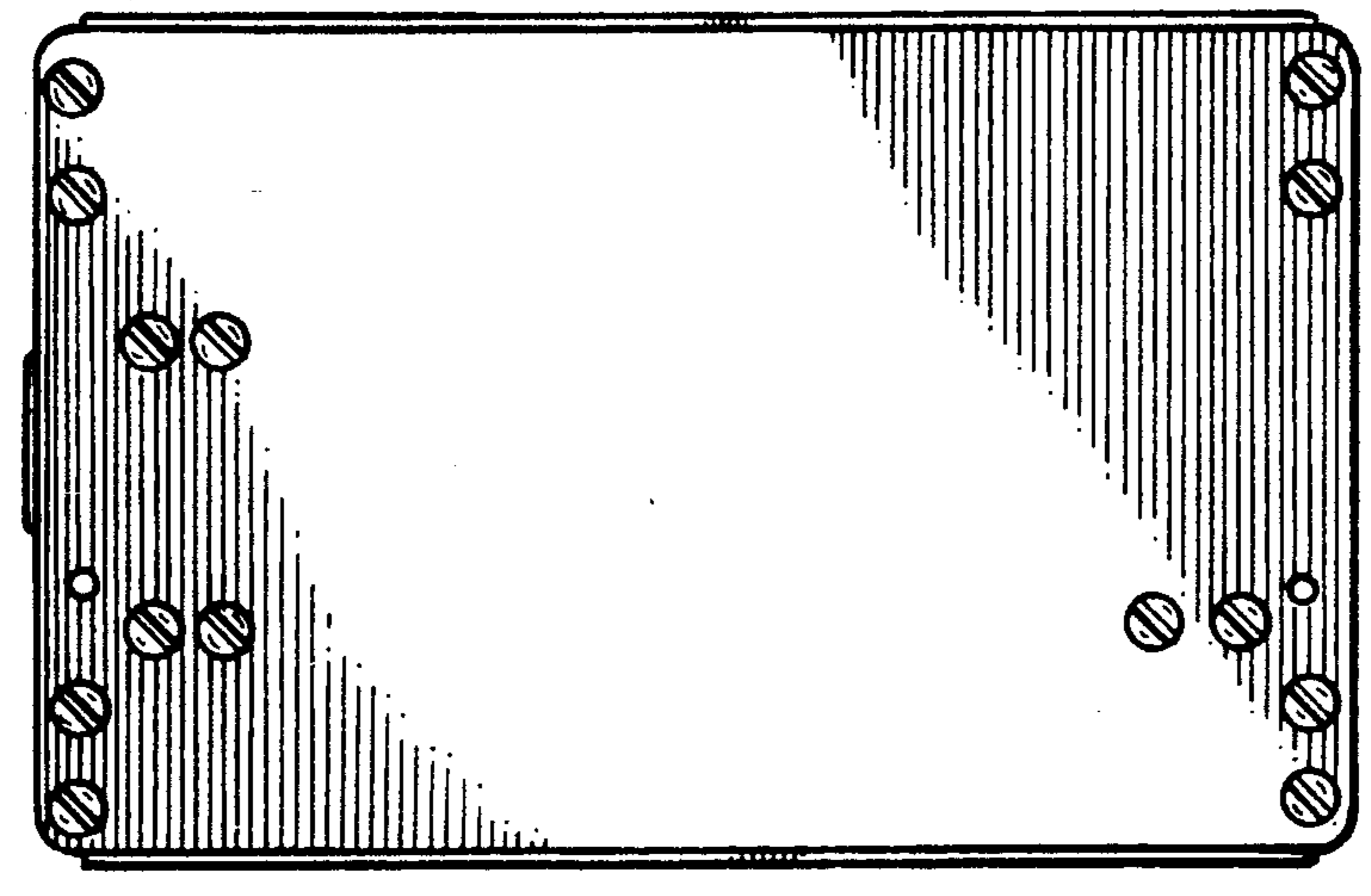

FIG. 5

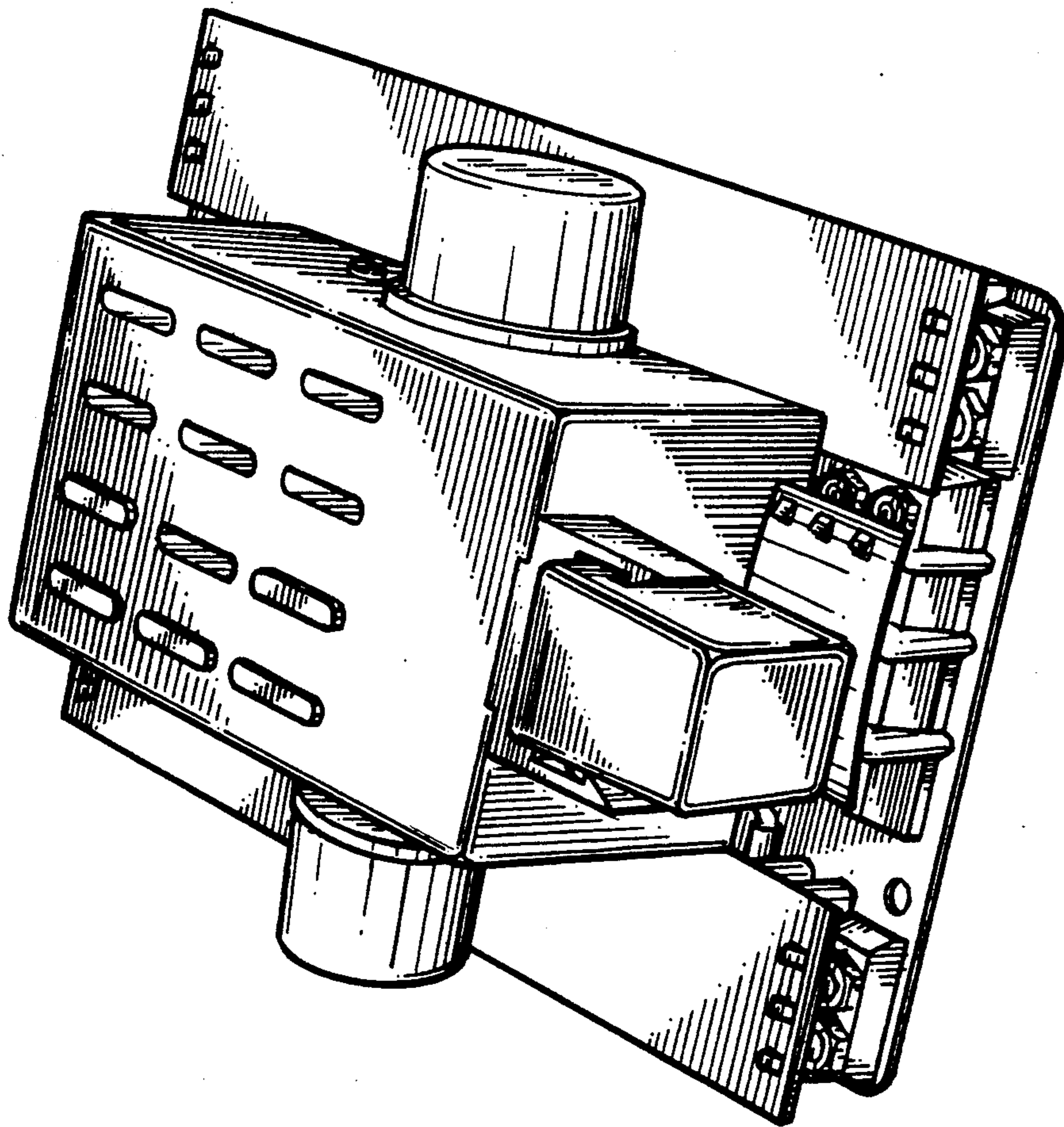

FIG. 6

UNITED STATES PATENT AND TRADEMARK OFFICE
CERTIFICATE OF CORRECTION

PATENT NO. : Des. 330,007
DATED : October 6, 1992
INVENTOR(S) : Ron Francis

It is certified that error appears in the above-identified patent and that said Letters Patent is hereby corrected as shown below.

On the title page:

In the "Description", FIG. 1, line 2, delete the phrase "automobile engines" and in its stead place the phrase --motor vehicles--

Signed and Sealed this
Twenty-eighth Day of September, 1993



Attest:

BRUCE LEHMAN

Attesting Officer

Commissioner of Patents and Trademarks