



US00D329876S

United States Patent [19]

[11] Patent Number: **Des. 329,876**

Breen

[45] Date of Patent: **** Sep. 29, 1992**

[54] **COMPARTMENTED ORGANIZER FOR OFFICE SUPPLIES**

[75] Inventor: **John D. Breen**, Wooster, Ohio

[73] Assignee: **Rubbermaid Incorporated**, Wooster, Ohio

[**] Term: **14 Years**

[21] Appl. No.: **637,505**

[22] Filed: **Jan. 4, 1991**

[52] U.S. Cl. **D19/75; D19/77; D19/85; D6/476**

[58] Field of Search **D6/457, 476; D19/65, D19/75, 35, 36, 77, 78, 81-85, 86, 92, 95, 99, 100; 206/214, 371, 224; 311/69.1-69.9**

[56] **References Cited**

U.S. PATENT DOCUMENTS

D. 91,693	3/1934	Van Cleef	D6/476
D. 173,722	12/1954	Coté	D19/77 X
D. 249,608	9/1978	Wright	D6/476 X
D. 253,562	12/1979	Evans	D19/75 X
D. 267,618	1/1983	Liptak .	
D. 267,959	2/1983	Cheung	D19/85 X
D. 270,549	9/1983	Burton et al. .	
D. 279,385	6/1985	Lieberman	D19/85 X
D. 288,939	3/1987	Boon .	
D. 296,568	7/1988	Nadeau	D19/77
D. 303,552	9/1989	Ancona et al. .	
213,681	3/1879	Norris .	
4,003,471	1/1977	Alfano .	

OTHER PUBLICATIONS

Pp. 9, 10, 11 and 13, Park Sherman, a Division of

Ketcham & McDougall, Inc., 464 Eagle Rock Ave., Roseland, N.J. 07068, Publication date 1985-1986. Pp. 12, 15, Eldon Industries, Inc., P.O. Box 22667, Long Beach, Calif. 90801-5667, Publication date 1989. Catalog Page, W. T. Rogers, 1401 W. Badger Rd., Box 4327, Madison, Wi. 53711, Publication date 1987. P. 116 Ken Mark Company, Ltd., P.O. Box 87-289, Taipei, Taiwan, R.O.C., Publication date unknown. P. 125, Sunny Creation Company, Ltd., P.O. Box 44-219, Taipei, Taiwan, R.O.C., Publication date unknown.

Primary Examiner—Nelson C. Holtje
Assistant Examiner—Martha Thompson
Attorney, Agent, or Firm—Richard B. O'Planick

[57] **CLAIM**

The ornamental design for a compartmented organizer for office supplies, as shown and described.

DESCRIPTION

FIG. 1 is a top, right front perspective view of a compartmented organizer for office supplies showing my new design; FIG. 2 is a front elevational view; FIG. 3 is a rear elevational view; FIG. 4 is a right side elevational view; FIG. 5 is a left side elevational view; FIG. 6 is a top plan view; and, FIG. 7 is a bottom plan view thereof. FIGS. 2 through 7 have been drawn to an enlarged scale with respect to FIG. 1.

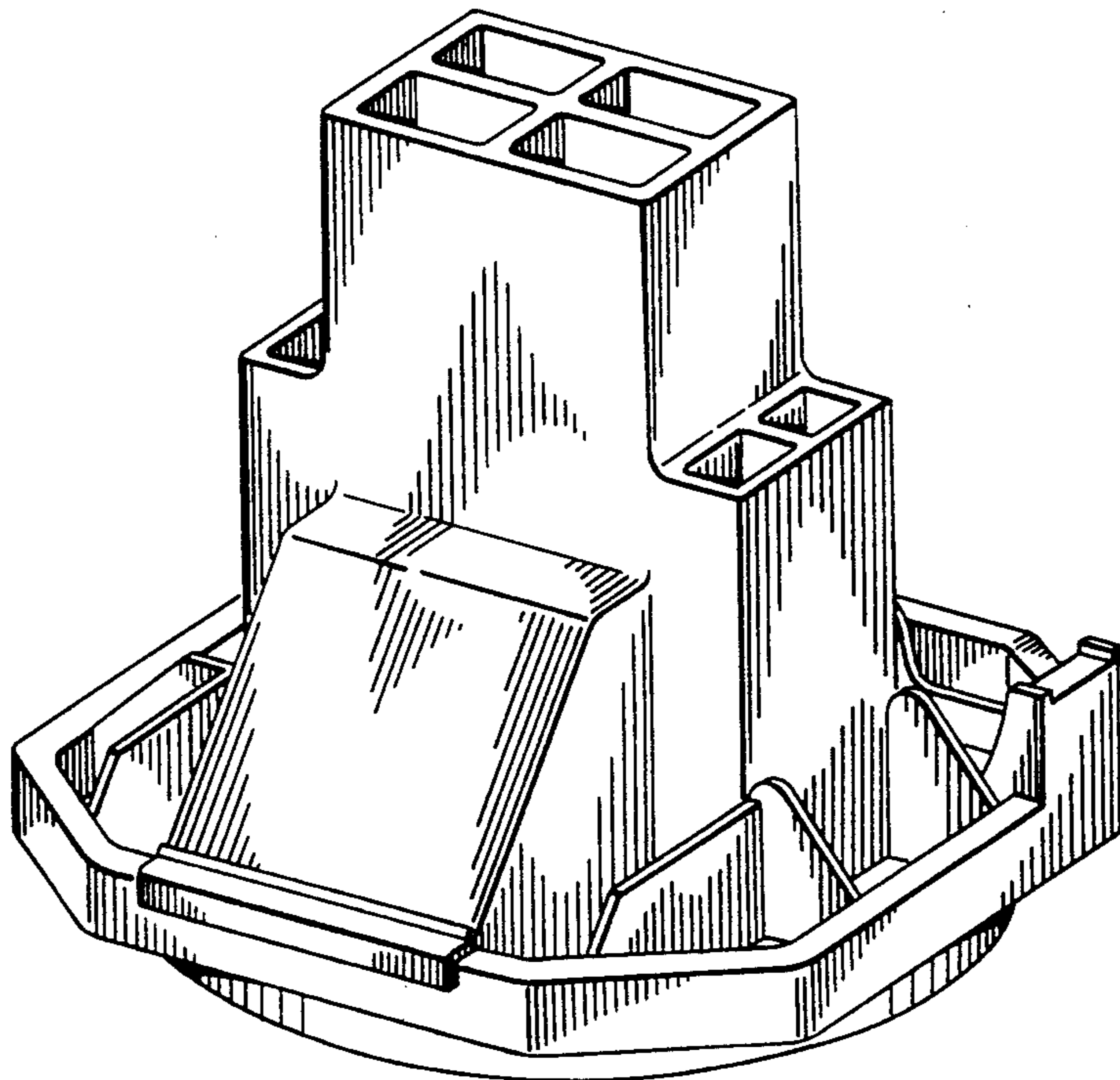

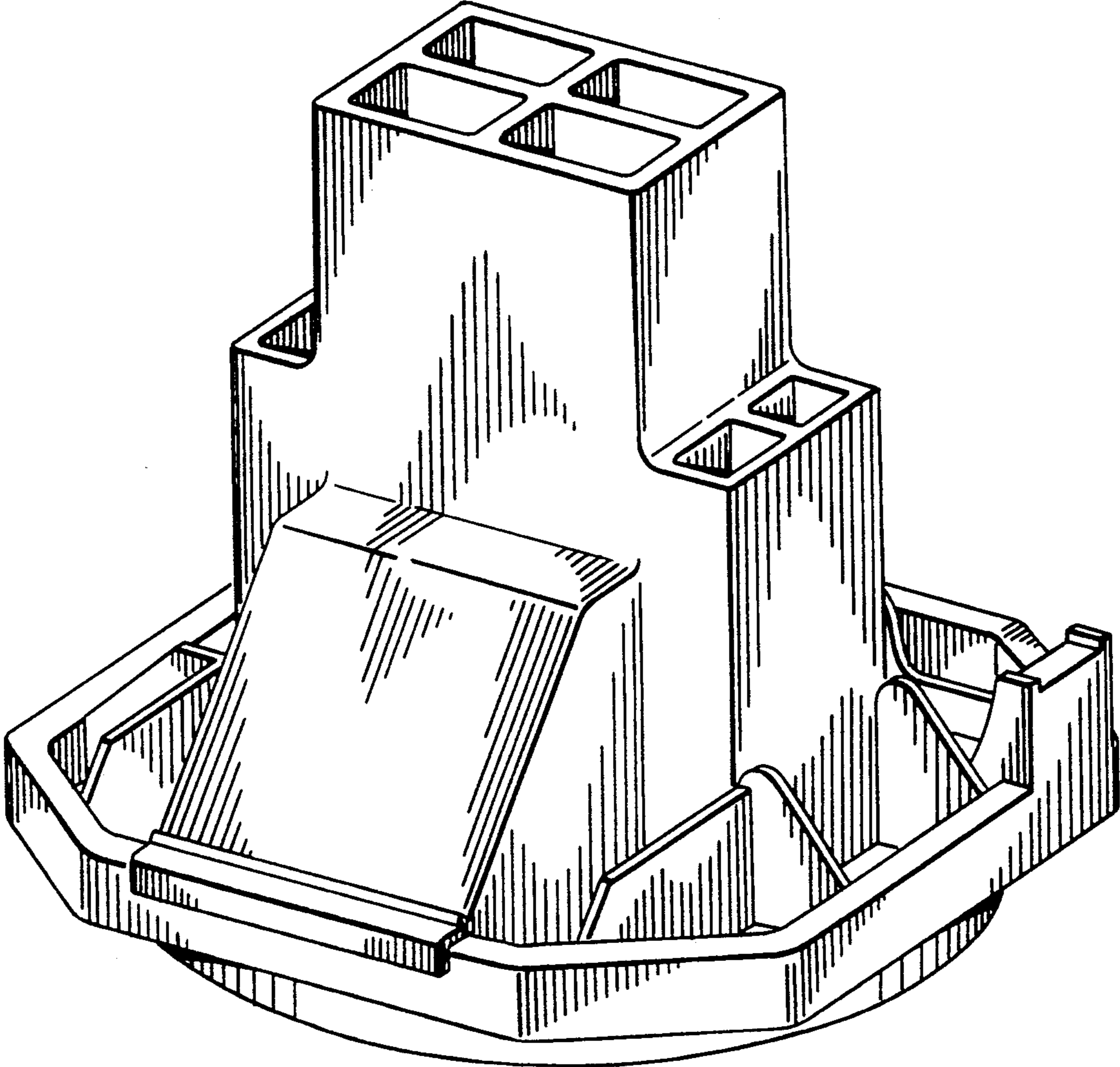

FIG. 1

FIG. 2

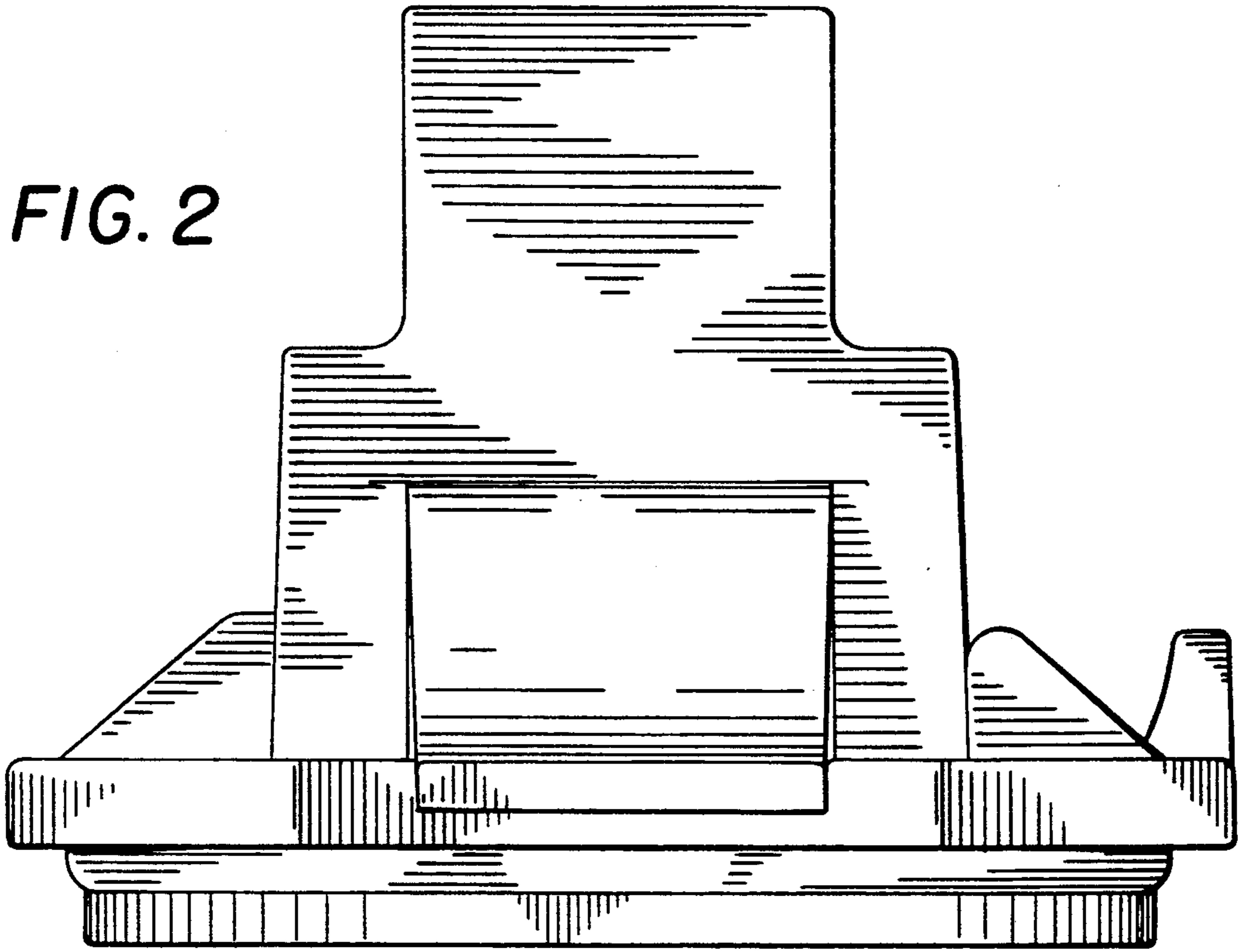

FIG. 3

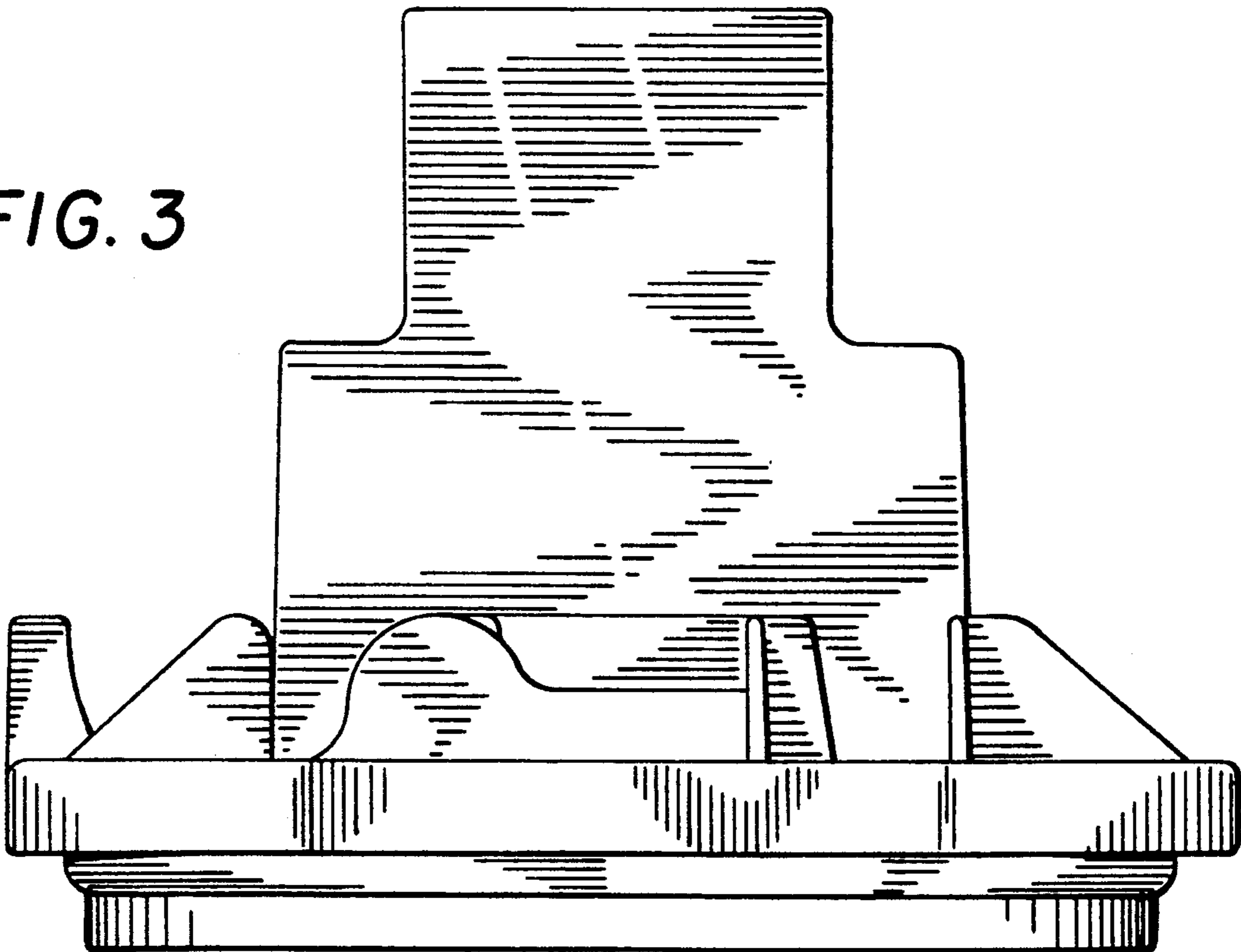

FIG. 4

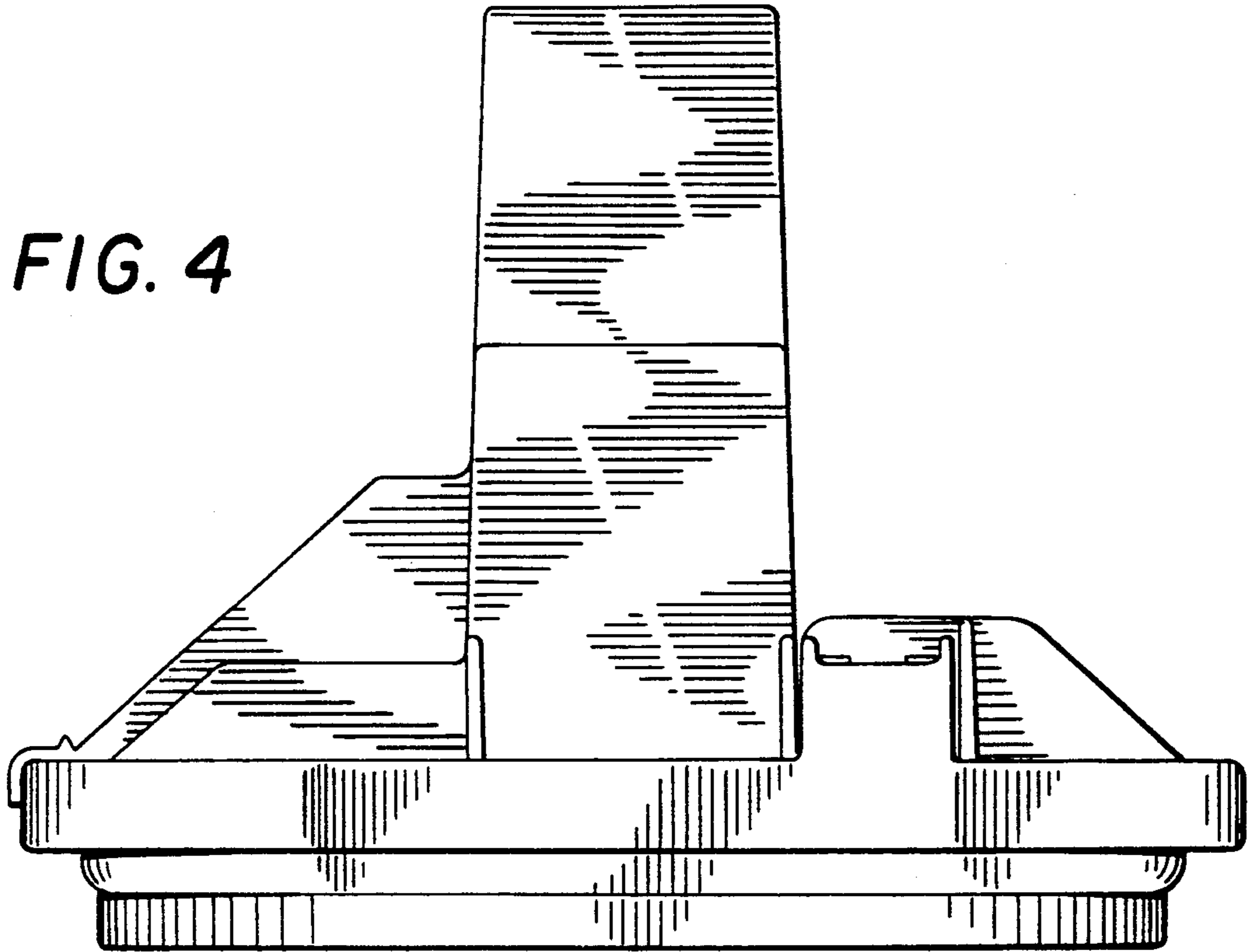
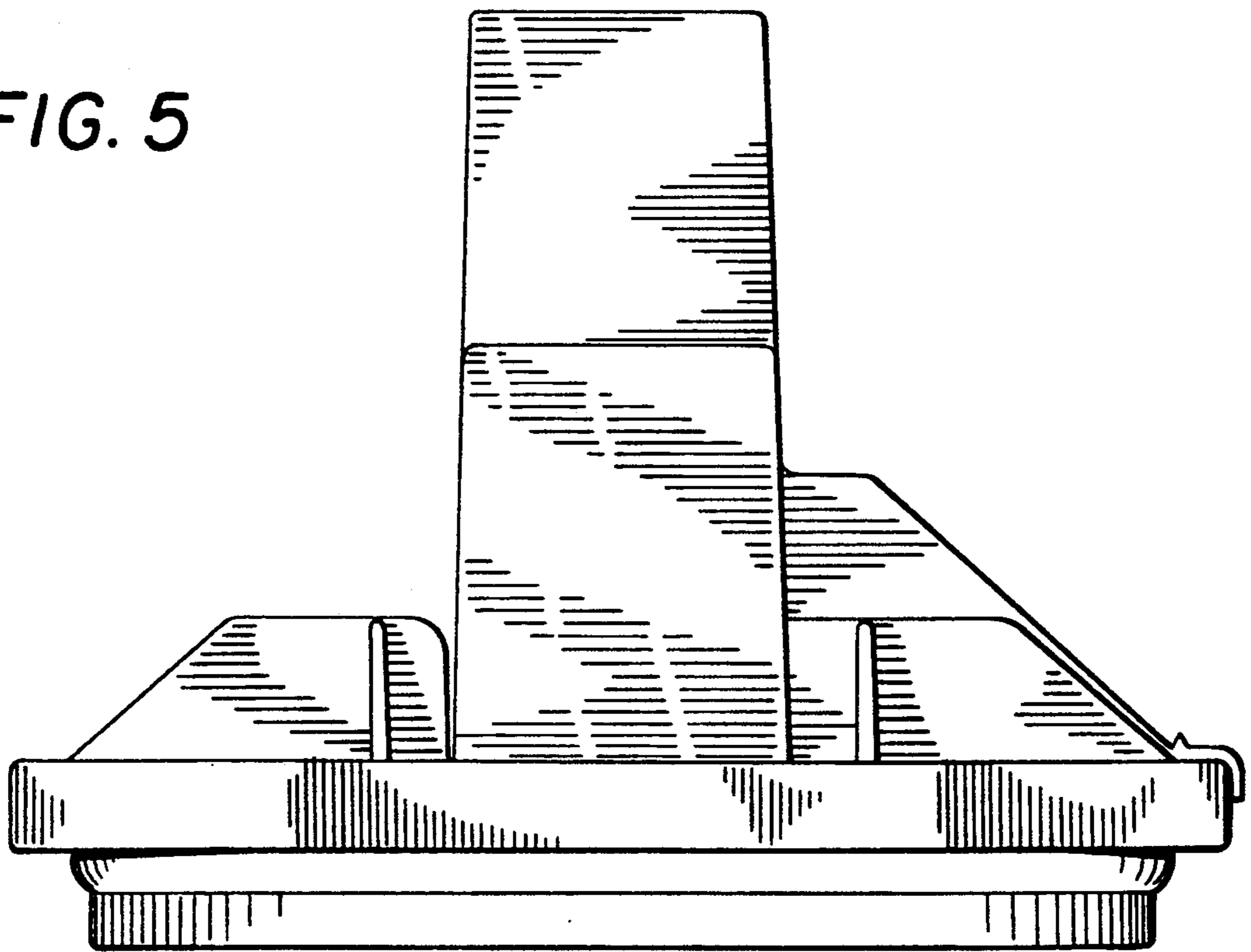

FIG. 5



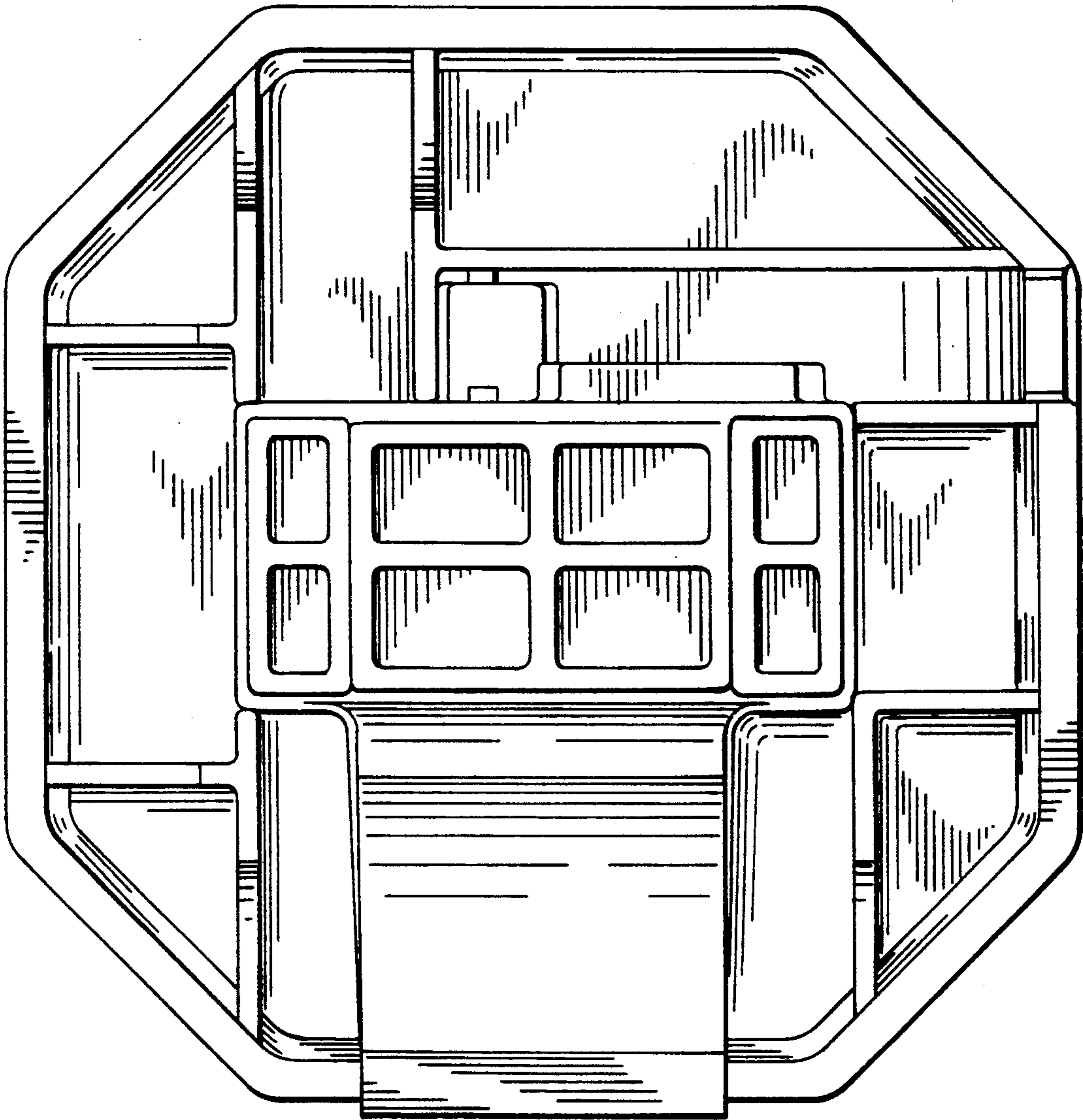

FIG. 6

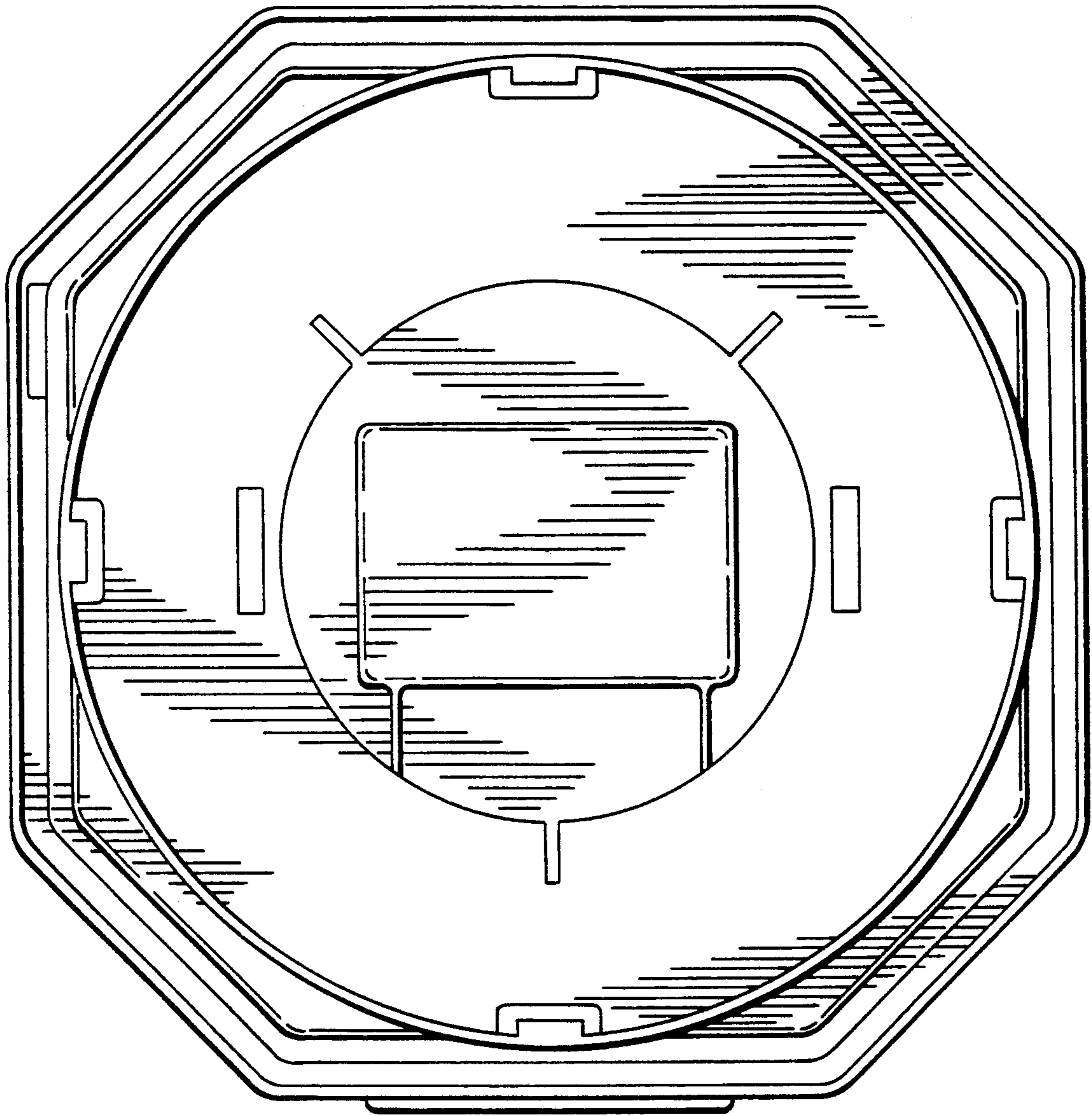

FIG. 7