



US00D329728S

# United States Patent [19]

[11] Patent Number: **Des. 329,728**

Ladek

[45] Date of Patent: **\*\* Sep. 22, 1992**

[54] **PIER LIFTING FOR ELEVATING BUILDING FOOTINGS**

[75] Inventor: **Francis P. Ladek, St. Louis, Mo.**

[73] Assignee: **Central States Waterproofing of Missouri, Inc., St. Louis, Mo.**

[\*\*] Term: **14 Years**

[21] Appl. No.: **486,718**

[22] Filed: **Feb. 28, 1990**

[52] U.S. Cl. .... **D34/28**

[58] Field of Search ..... **D34/28; 254/124; 405/230; 52/122.1, 125.1-125.2**

[55] **References Cited**

**U.S. PATENT DOCUMENTS**

570,370	10/1896	Breuchaud .	
598,418	2/1898	Gillespie .	
2,982,103	5/1961	Revesz .	
3,685,301	8/1972	Heacox .	
3,796,055	3/1974	Mahony .....	405/230
3,902,326	9/1975	Langenbach, Jr. .	
4,634,319	1/1987	May .	
4,673,315	6/1987	Shaw et al. .	
4,678,373	7/1987	Langebach, Jr. .	
4,765,777	8/1988	Gregory .	
4,854,782	8/1989	May .....	405/230

**OTHER PUBLICATIONS**

Brochure-Haynes Construction Co., Ballwin, MO. "Permanent Piering System" No date.

Brochure-The Perma Jack System-#4 Perma-Jack System being Installed.-No date, (See above-U.S. Pat. No. 3,902,326).

Brochure-Atlas Piers-Copyright 1986-Specifications List.

*Primary Examiner*-Wallace R. Burke  
*Assistant Examiner*-H. Baynham  
*Attorney, Agent, or Firm*-Paul M. Denk

[57] **CLAIM**

The ornamental design for the a pier lifter for elevating building footings, as shown and described.

**DESCRIPTION**

FIG. 1 is a perspective view of a pier lifter for elevating building footings showing my new design; FIG. 2 is a top plan view thereof; FIG. 3 is a left side elevational view thereof with the right side being a mirror image; FIG. 4 is a bottom plan view thereof; FIG. 5 is a front elevational view thereof; and, FIG. 6 is a rear elevational view thereof. The broken line showing of a pipe shaft is for illustrative purposes only and forms no part of the claimed design.

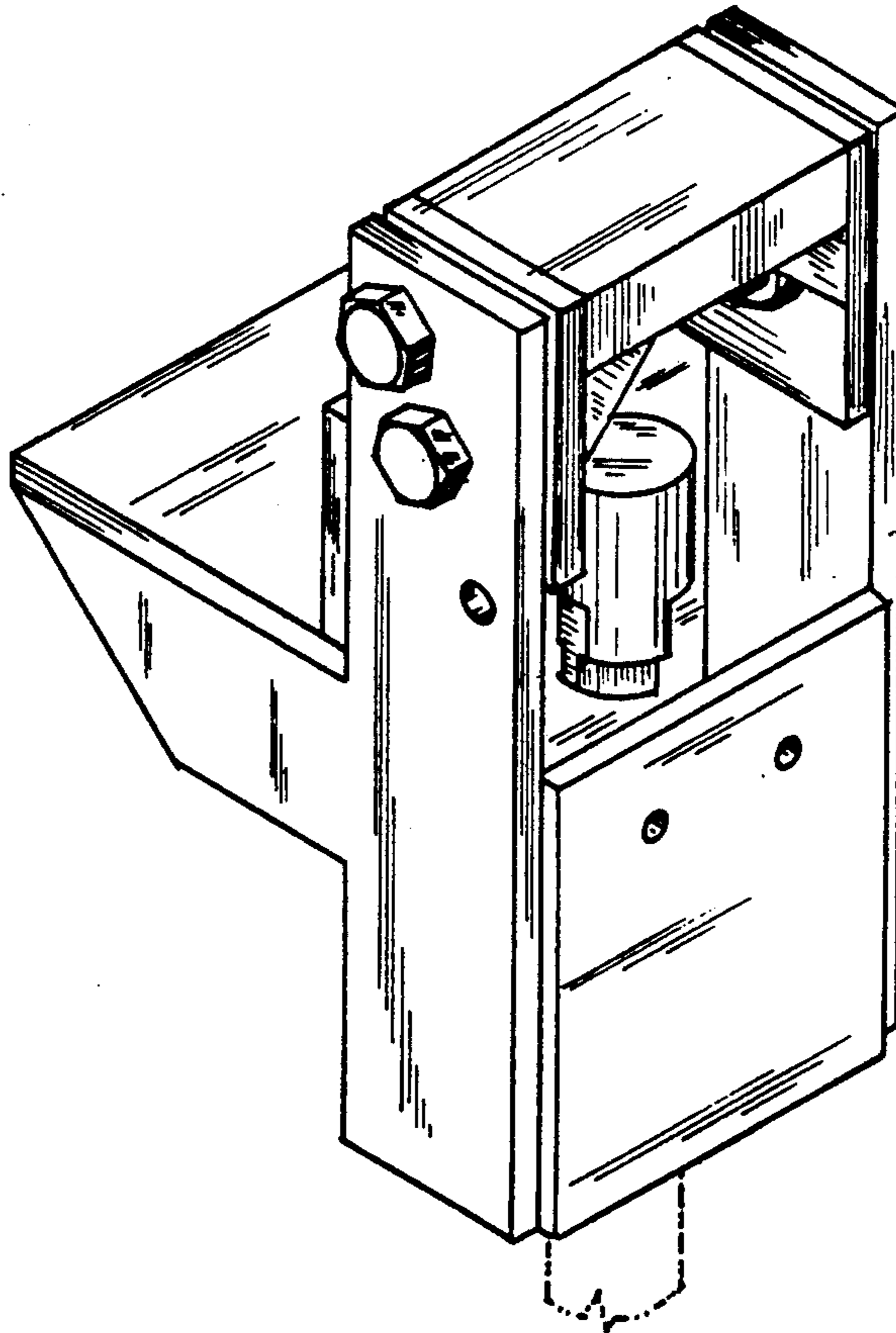

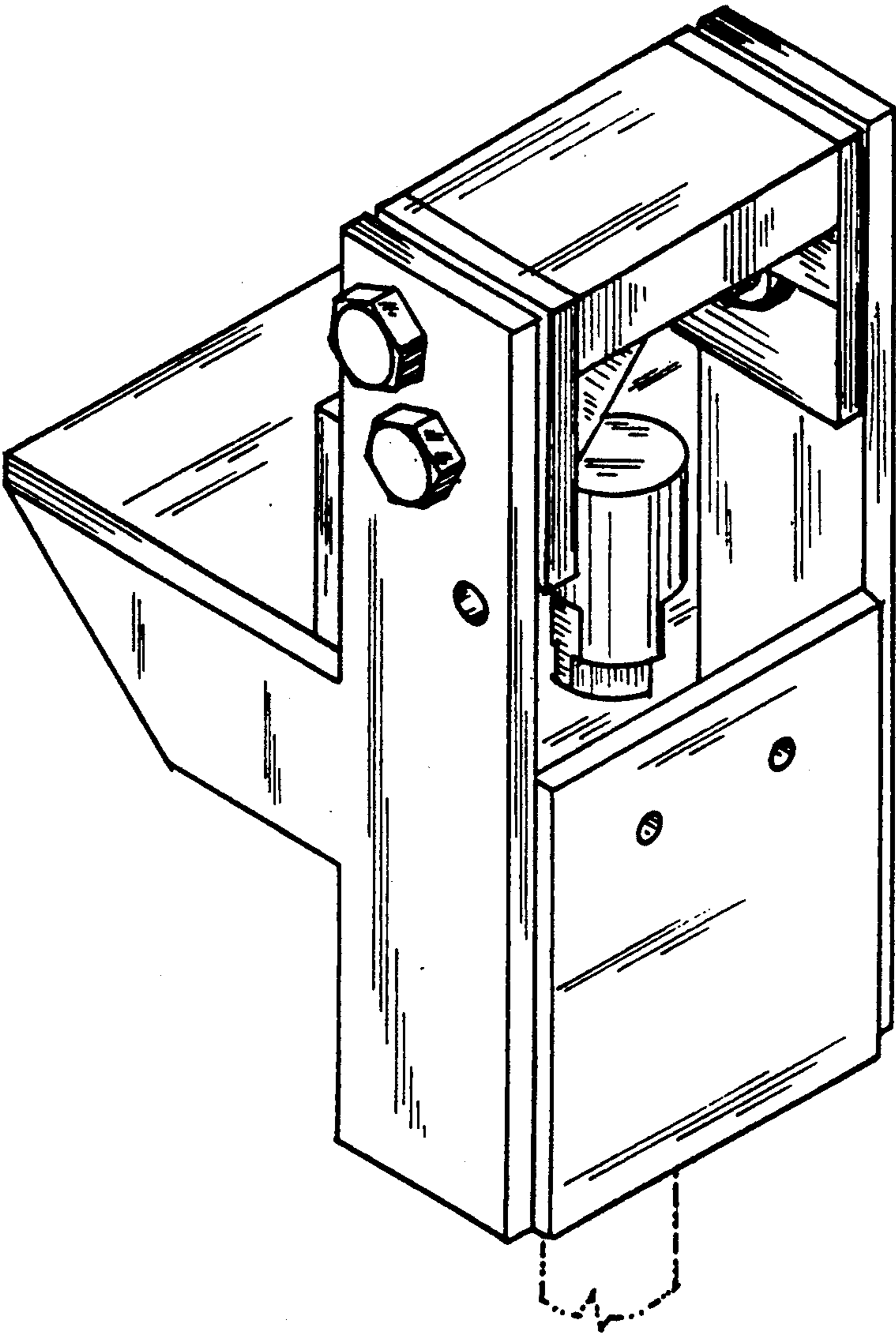

FIG. 1.

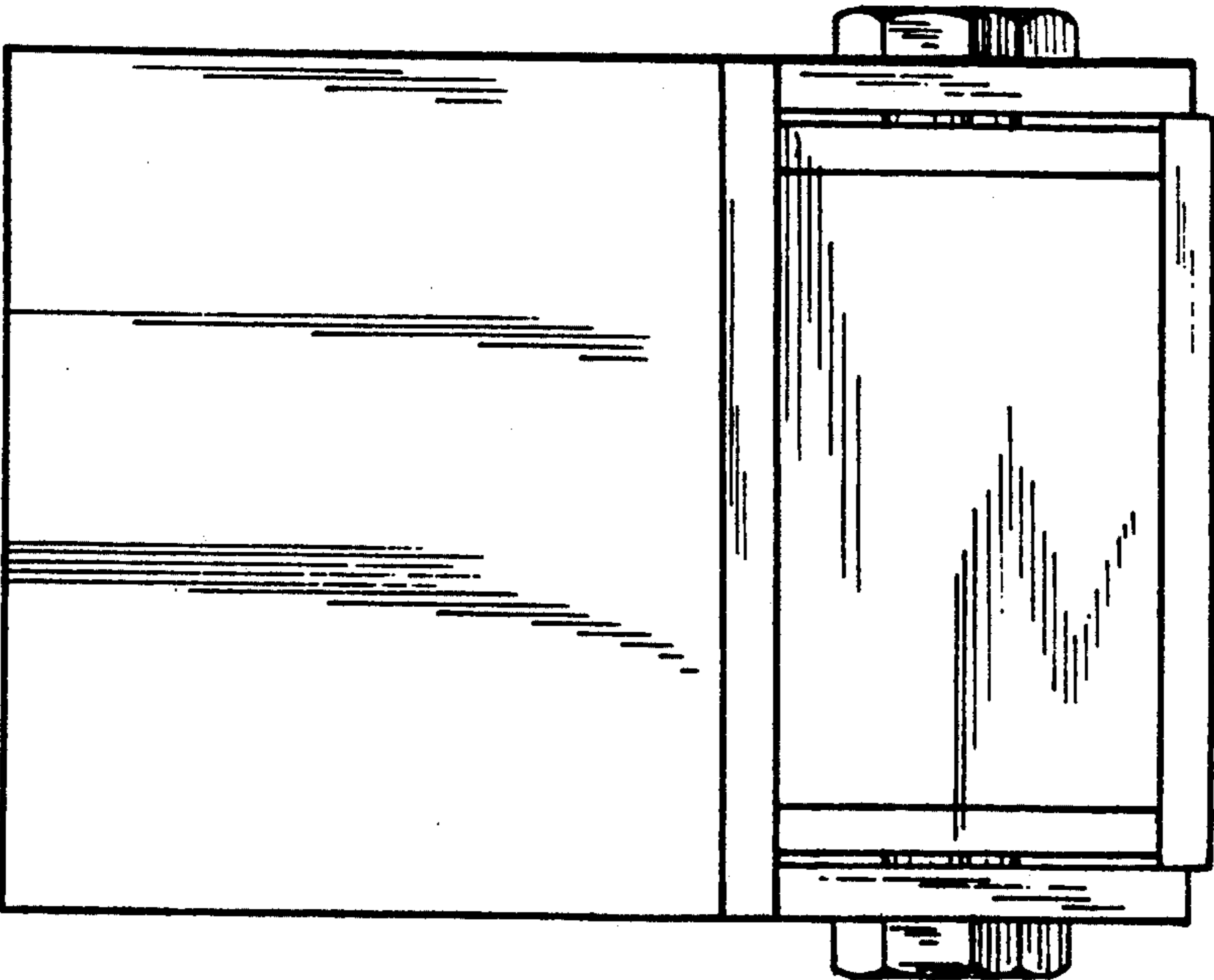

FIG. 2.

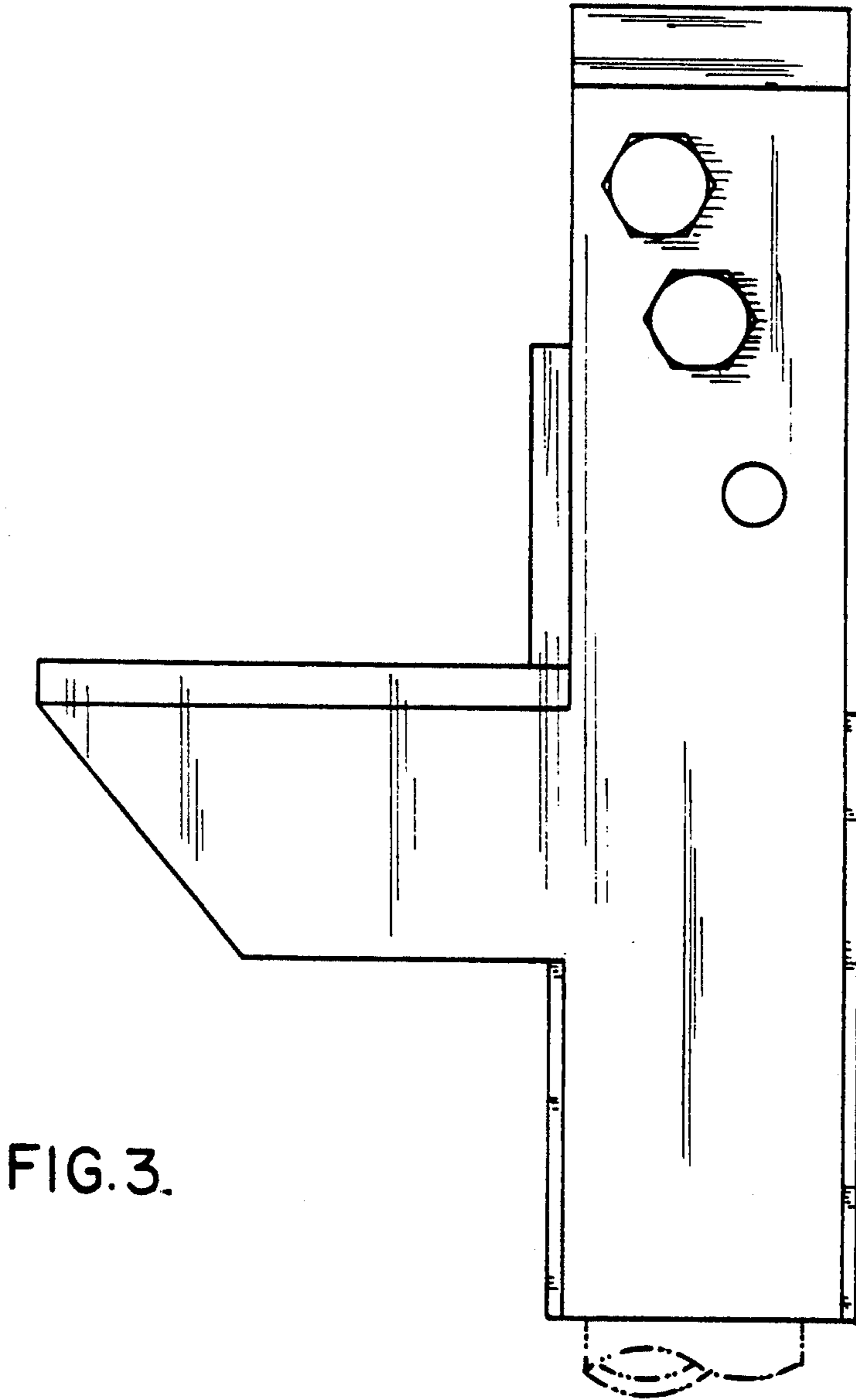

FIG. 3.

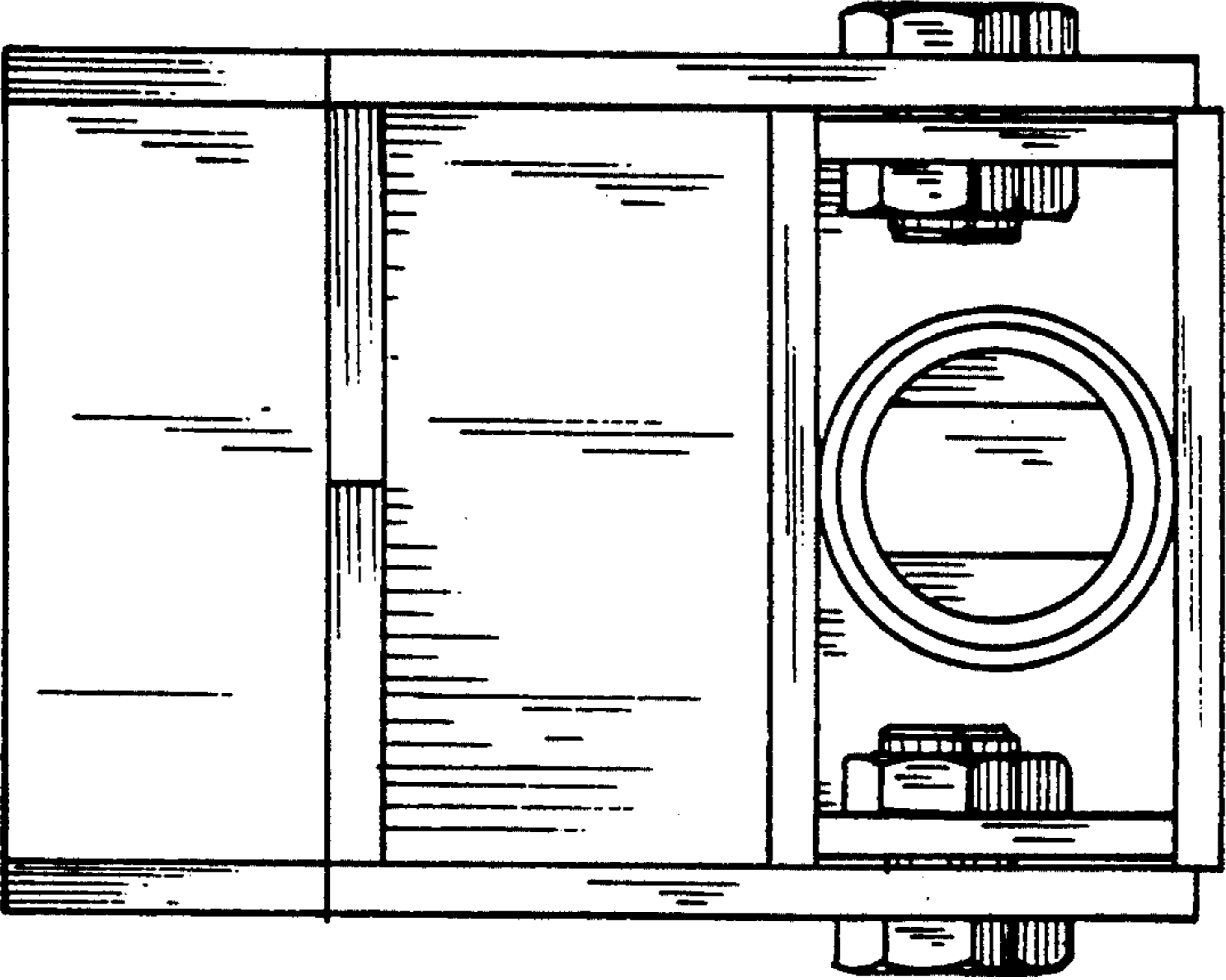

FIG. 4.

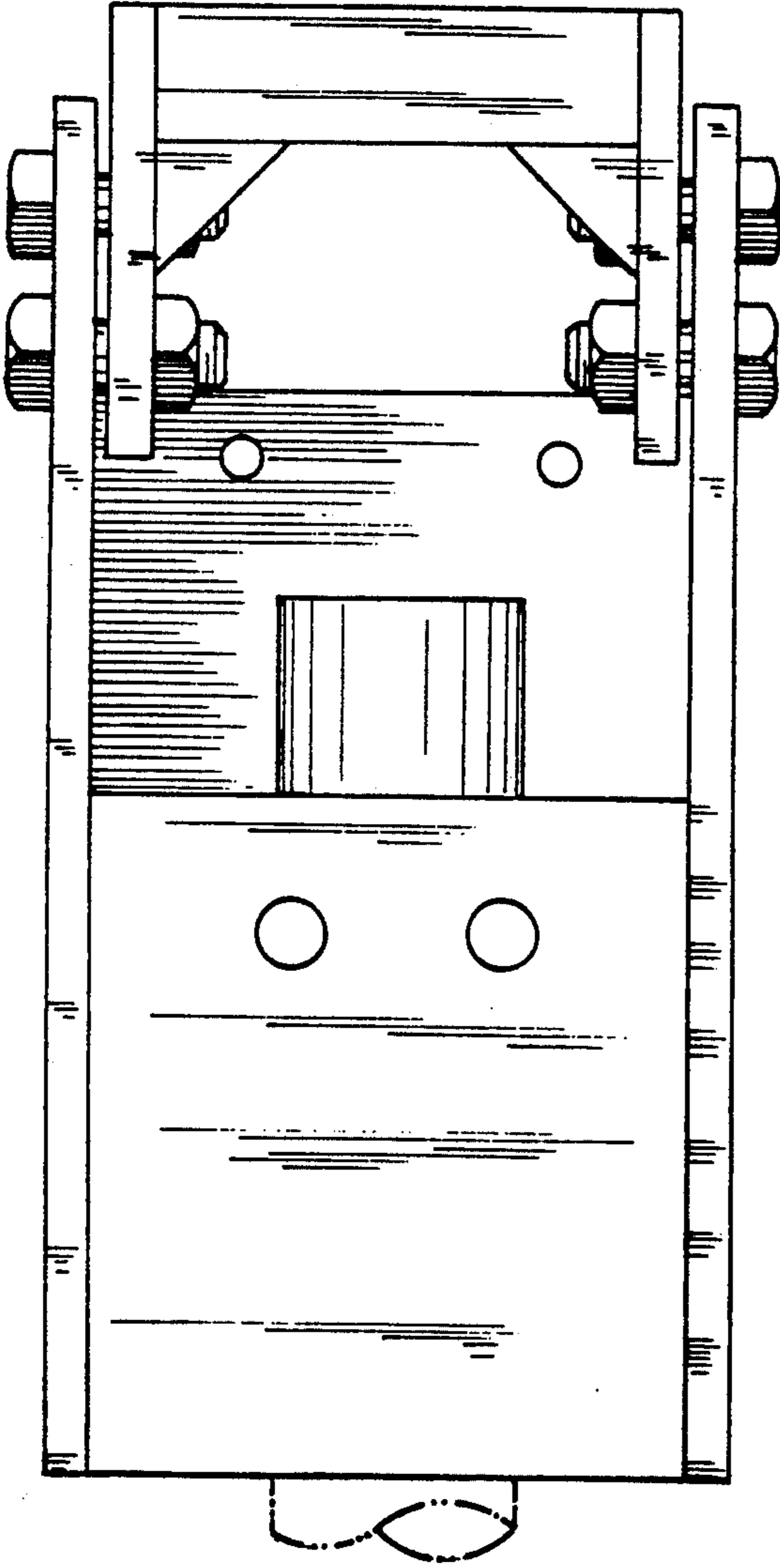

FIG. 5.

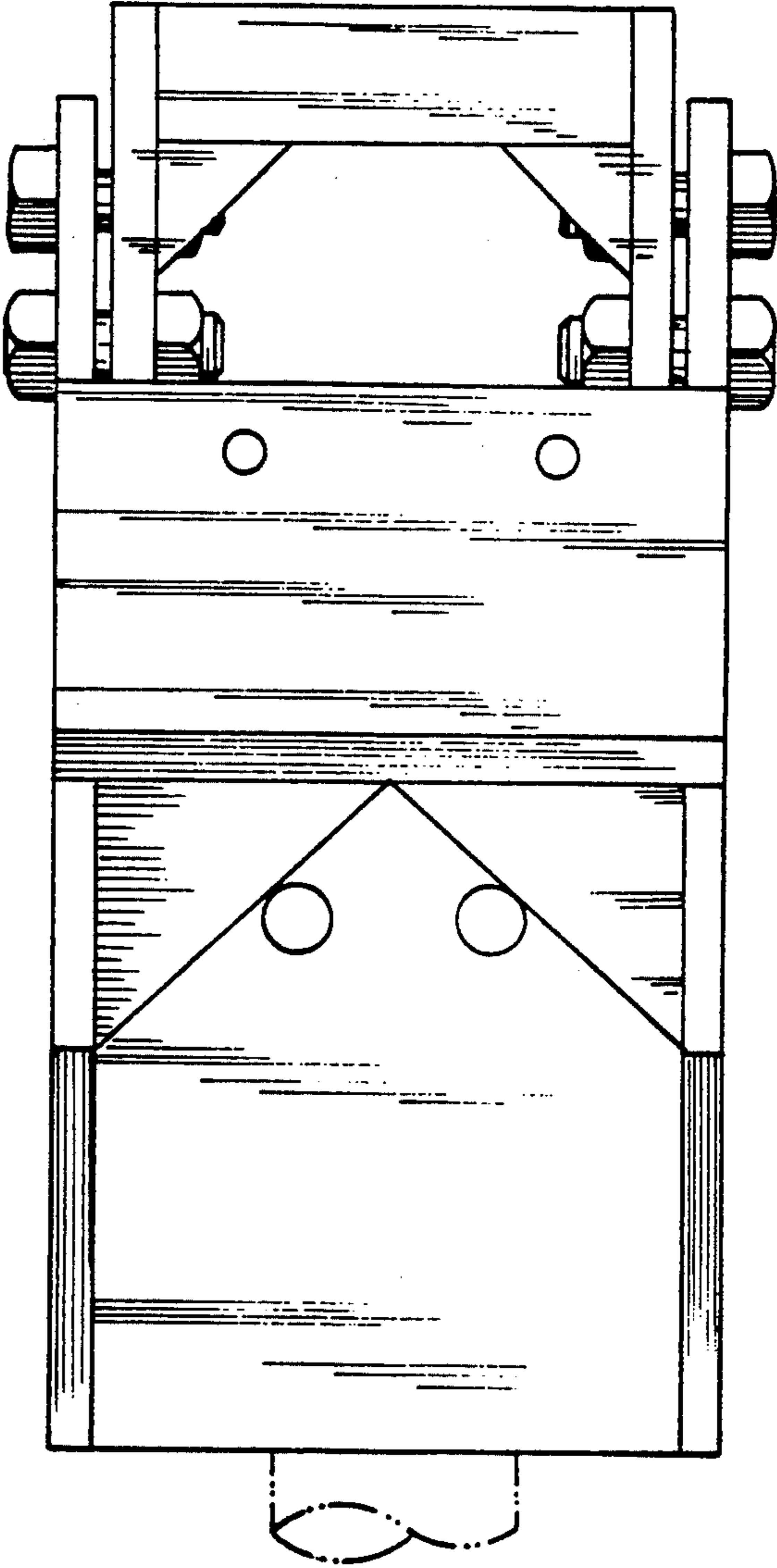

FIG. 6.