



US00D329428S

# United States Patent [19]

Yoshida et al.

[11] Patent Number: **Des. 329,428**

[45] Date of Patent: **\*\* Sep. 15, 1992**

## [54] FACSIMILE

[75] Inventors: **Toshiya Yoshida; Masaki Hara; Masato Goto**, all of Kanagawa; **Katsunori Takagi**, Hyogo, all of Japan

[73] Assignee: **Mitsubishi Denki Kabushiki Kaisha**, Tokyo, Japan

[\*\*] Term: **14 Years**

[21] Appl. No.: **460,725**

[22] Filed: **Jan. 4, 1990**

## [30] Foreign Application Priority Data

Jul. 13, 1989 [JP] Japan ..... 1-25937  
[52] U.S. Cl. .... **D14/118**  
[58] Field of Search ..... D14/107, 109, 118, 124, D14/217, 299; D18/36-37; 358/400-401

## [56] References Cited

### U.S. PATENT DOCUMENTS

D. 301,035 5/1989 Ooie ..... D14/118  
D. 304,578 11/1989 Saegusa et al. .... D14/118  
D. 312,632 12/1990 Furuya ..... D14/118

## OTHER PUBLICATIONS

The Office, May 1988, p. 134, top right—Comet portable facsimile.

Today's Office, Feb. 1987, p. 43, Sharp Model FO-200.

*Primary Examiner*—Theodore M. Shooman

*Attorney, Agent, or Firm*—Rothwell, Figg, Ernst & Kurz

## [57] CLAIM

The ornamental design for a facsimile, as shown and described.

## DESCRIPTION

FIG. 1 is a front elevational view of a facsimile showing our new design;

FIG. 2 is a left side elevational view thereof;

FIG. 3 is a top plan view thereof;

FIG. 4 is a rear elevational view thereof;

FIG. 5 is a right side elevational view thereof;

FIG. 6 is a bottom plan view thereof;

FIG. 7 is a right side elevational view thereof, with the stand in a raised position; and,

FIG. 8 is a top, front and left side perspective view thereof, the broken line showing being for illustrative purposes only and forming no part of the claimed design.

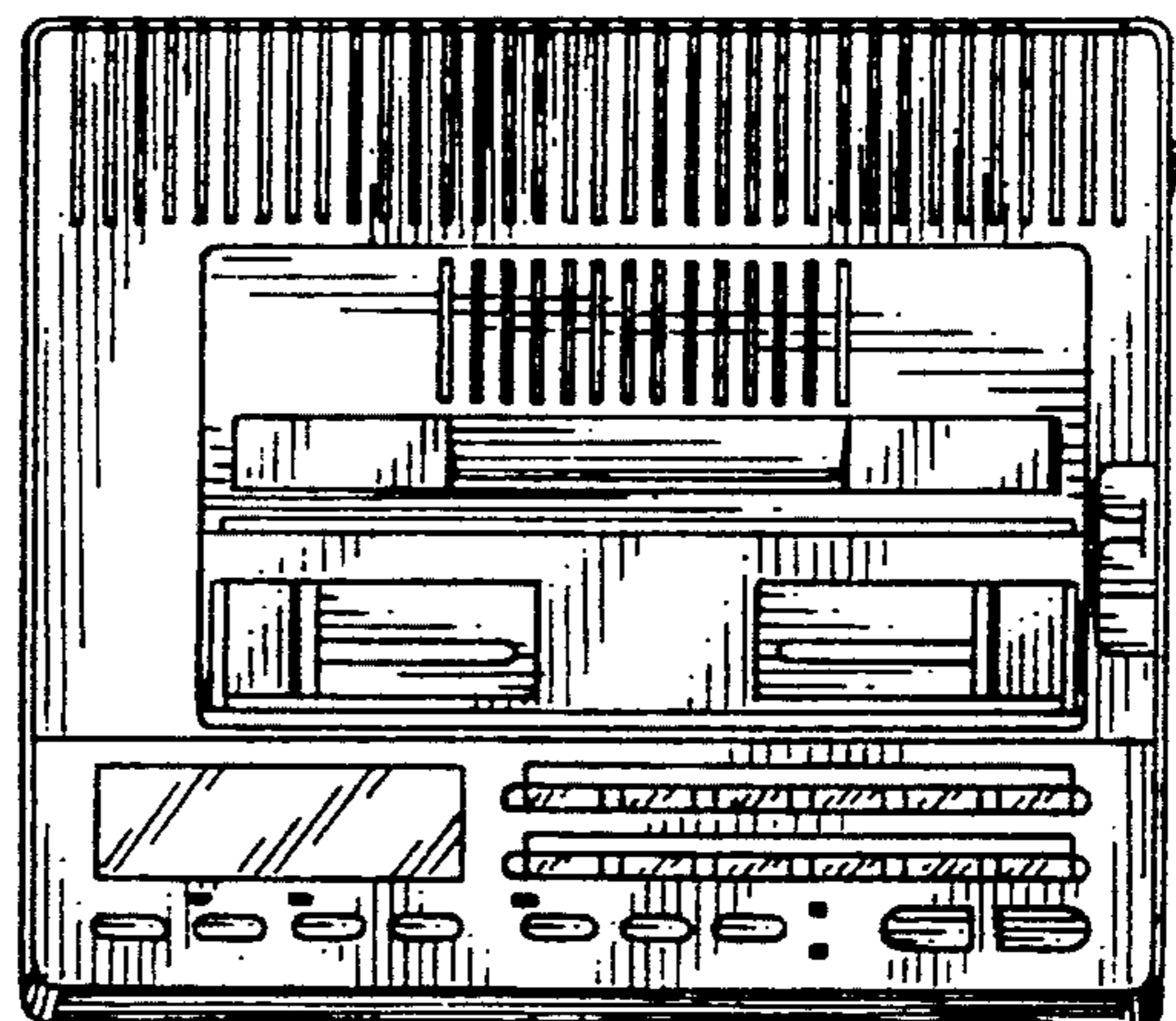
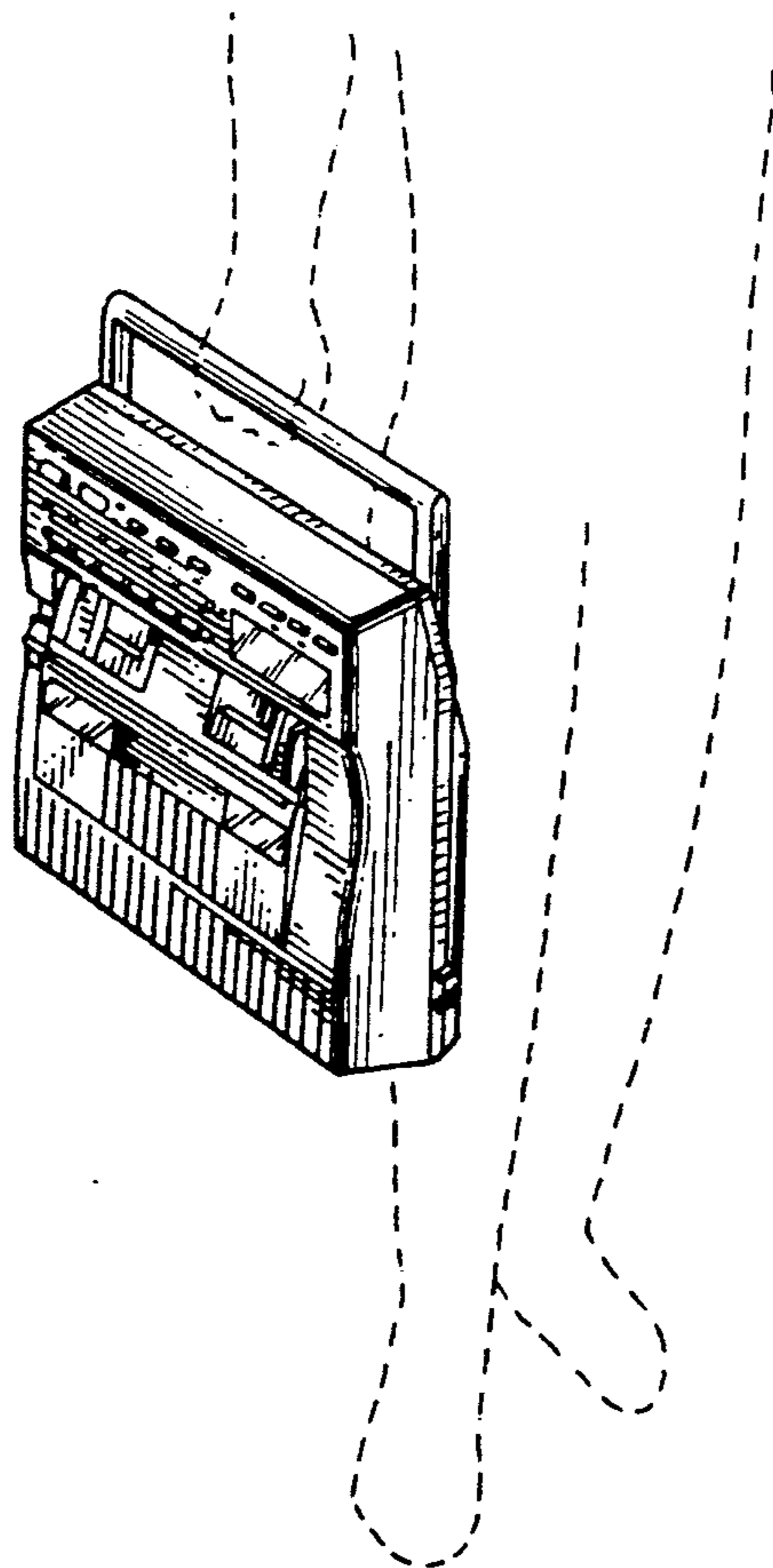

FIG. 1



FIG. 4



FIG. 2

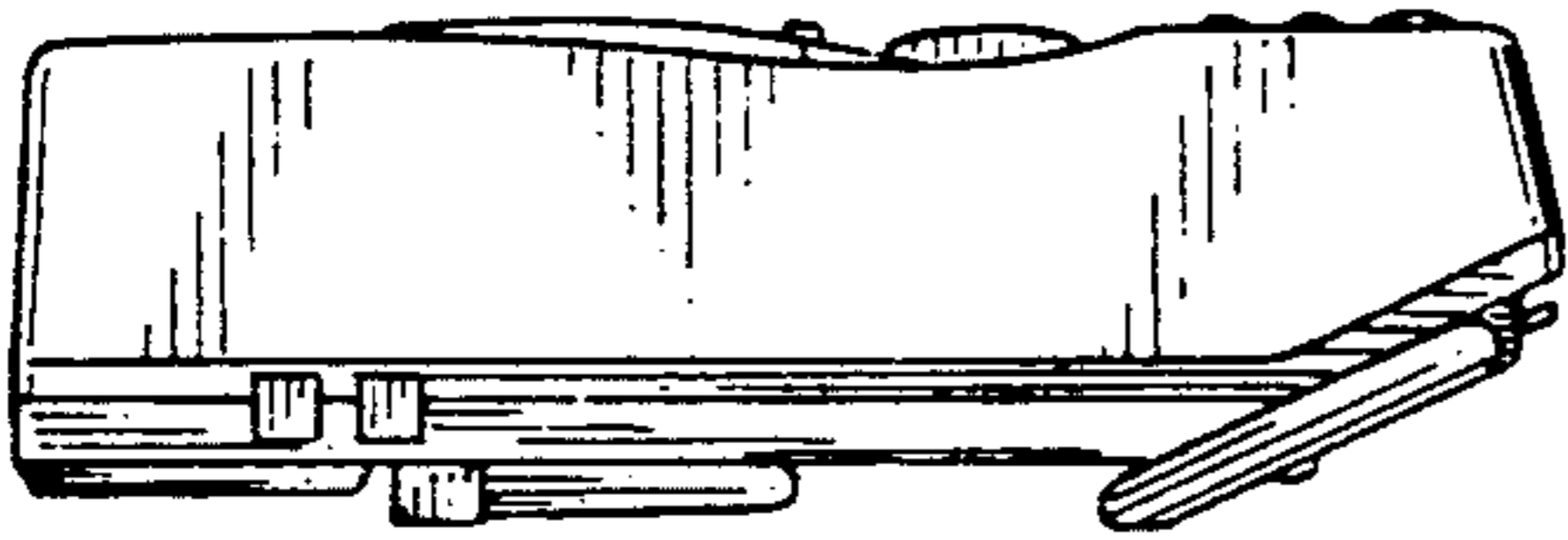

FIG. 5

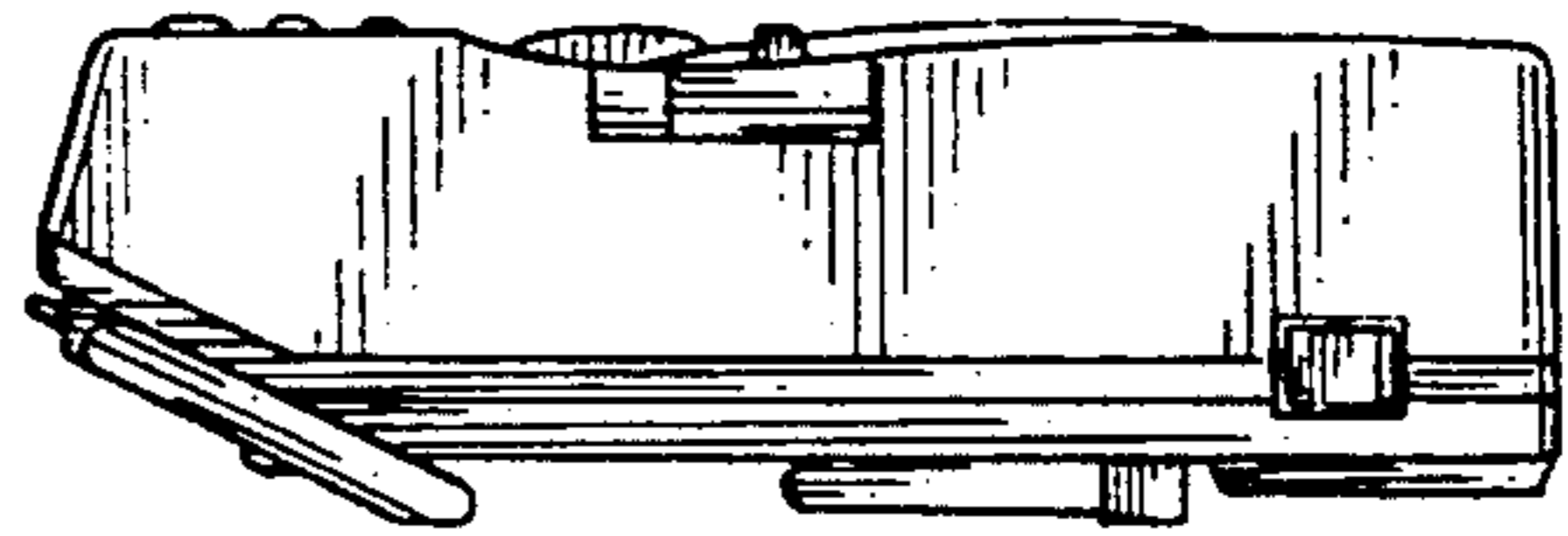

FIG. 3

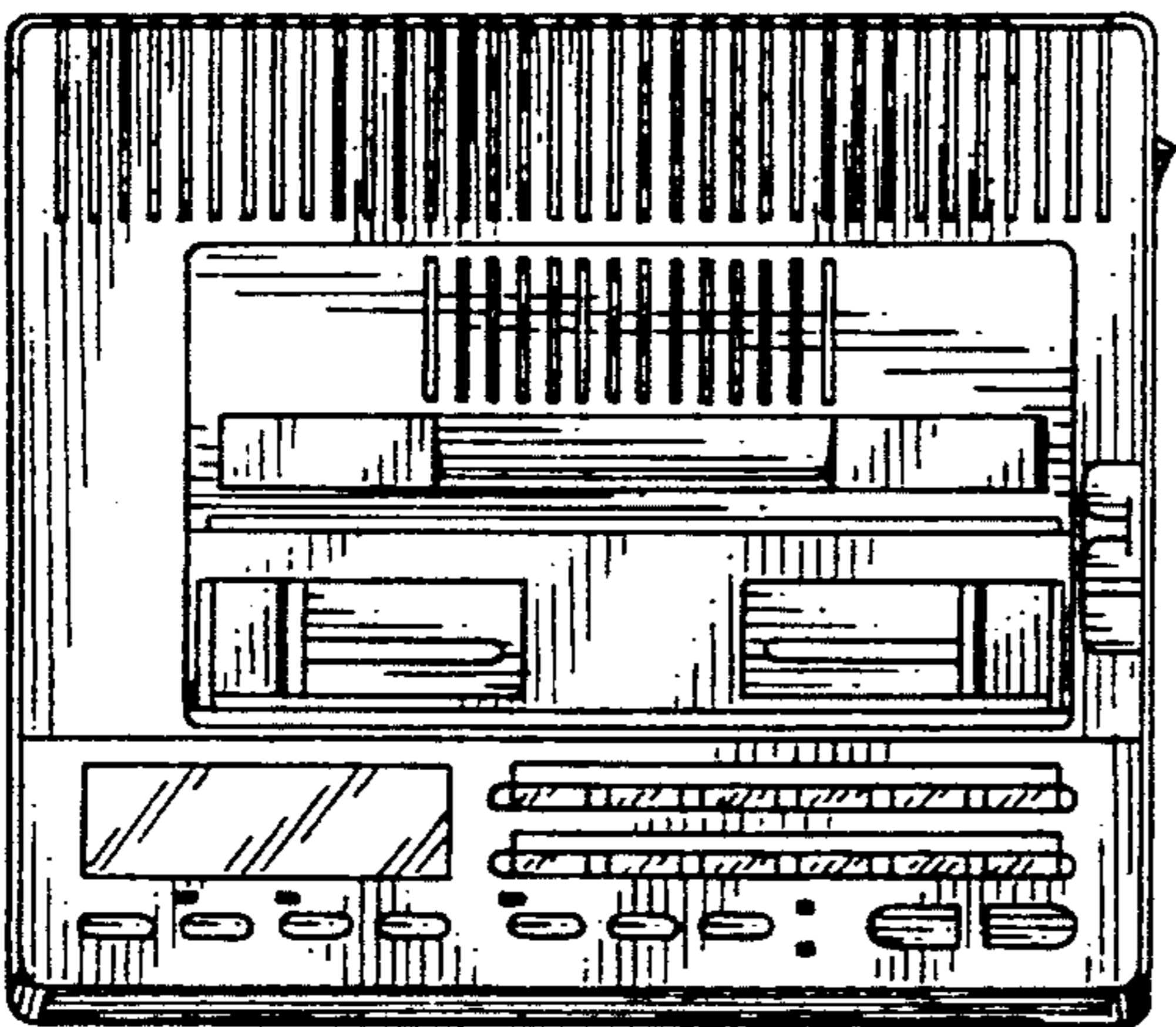

FIG. 6

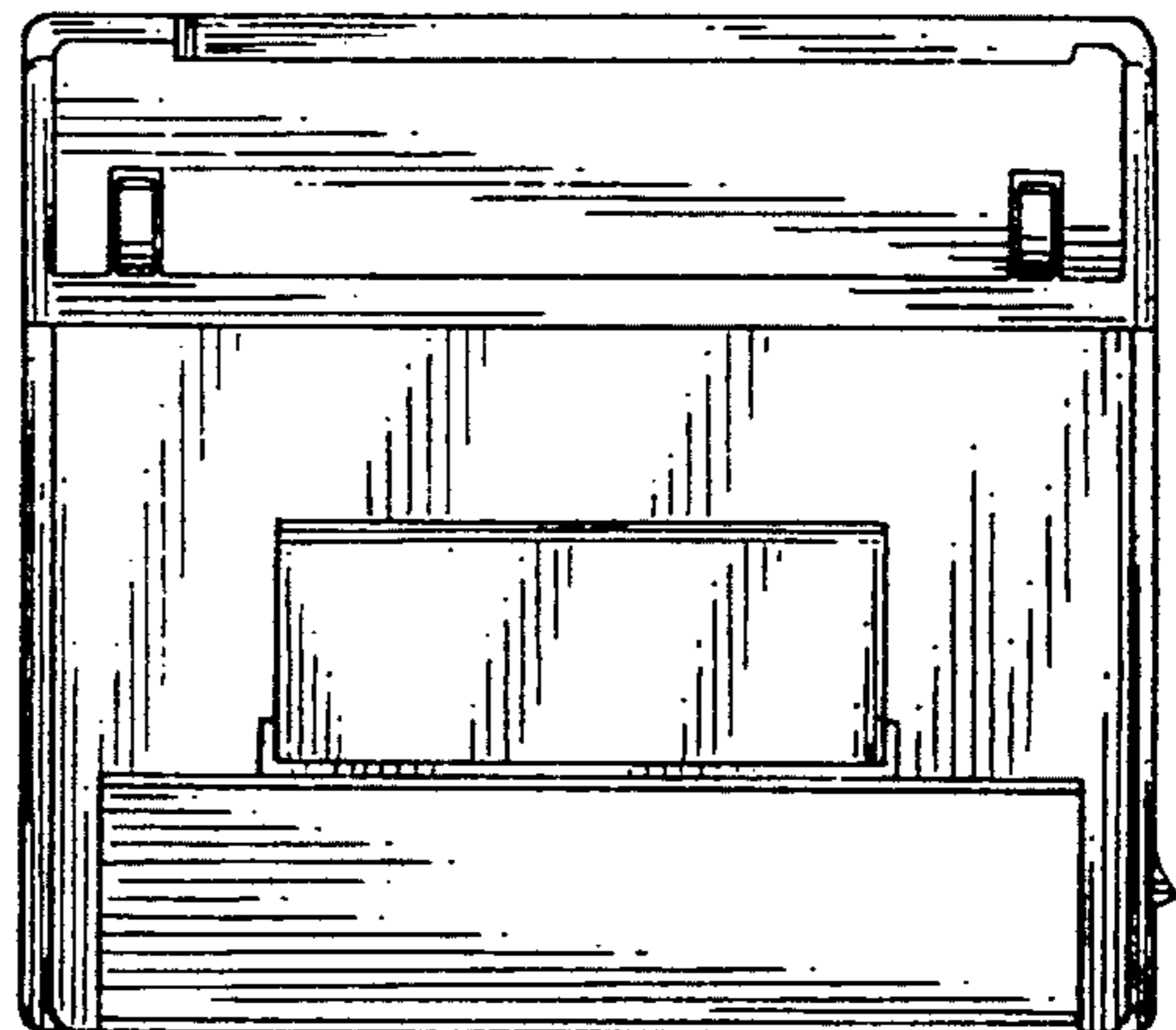

FIG. 7

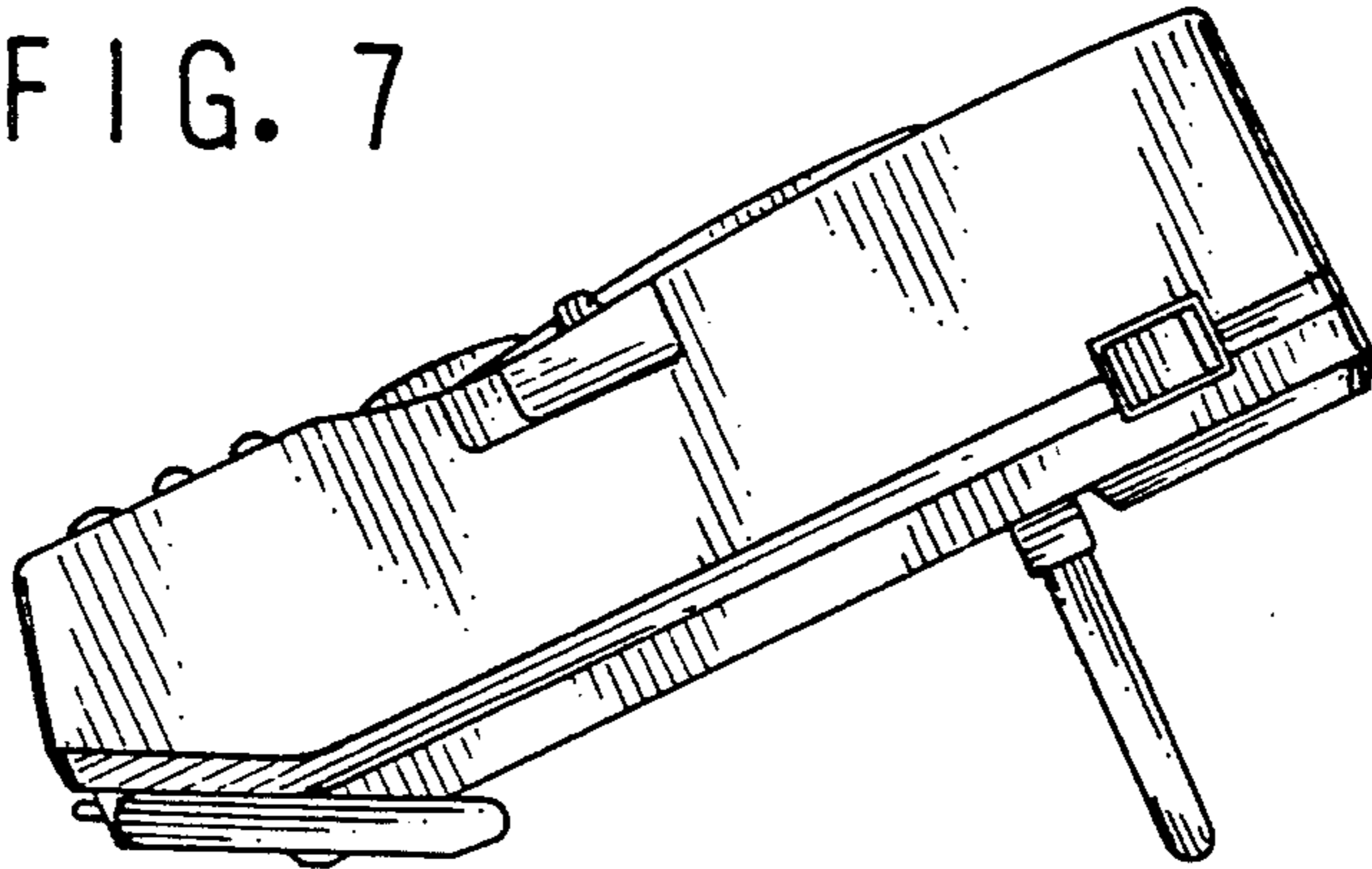

FIG. 8

