



US00D329420S

**United States Patent** [19]  
**Tsuchiya**

[11] **Patent Number: Des. 329,420**

[45] **Date of Patent: \*\* Sep. 15, 1992**

[54] **MOTORBOAT-LADDER**

4,768,618 9/1988 Ritten ..... 182/86

[76] **Inventor: Masayoshi Tsuchiya, 6-13-4,  
Mukoudai-chou, Tanashi-shi, Tokyo,  
Japan**

*Primary Examiner*—Kay H. Chin  
*Attorney, Agent, or Firm*—Edwin E. Greigg; Ronald E. Greigg

[\*\*] **Term: 14 Years**

[57] **CLAIM**

[21] **Appl. No.: 510,794**

The ornamental design for a motorboat-ladder, as shown and described.

[22] **Filed: Apr. 18, 1990**

**DESCRIPTION**

[52] **U.S. Cl. .... D12/317; D12/318;  
D25/62**

FIG. 1 is a perspective view of motorboat-ladder showing my new design;

[58] **Field of Search ..... D12/317, 318; 182/86,  
182/93, 91, 92, 106; 114/343**

FIG. 2 is a front elevational view thereof;

FIG. 3 is a top plan view thereof;

[56] **References Cited**

FIG. 4 is a right side elevational view thereof, the left side elevational view being a mirror image of that shown;

**U.S. PATENT DOCUMENTS**

2,924,291	2/1960	Tunslead	114/362
4,249,683	2/1981	Park	182/93
4,432,436	2/1984	Suiter	182/91
4,541,507	9/1985	Gibellato	182/86
4,637,492	1/1987	Herr	182/93
4,719,872	1/1988	Ritten	182/93

FIG. 5 is a rear elevational view thereof;

FIG. 6 is a bottom plan view thereof;

FIG. 7 is a cross-sectional view taken along line 7—7 of FIG. 2; and,

FIG. 8 is a cross-sectional view taken along line 8—8 of FIG. 4.

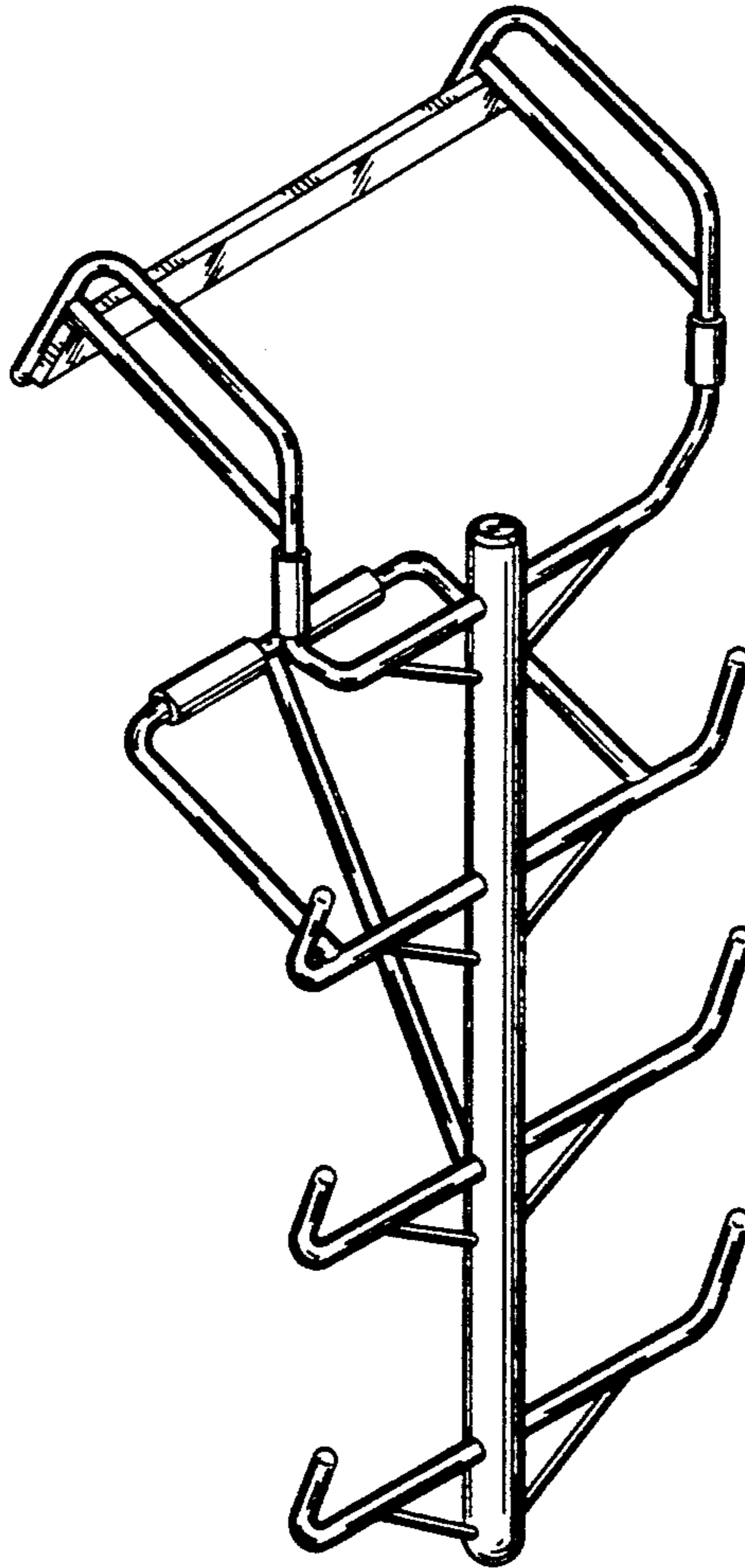

FIG. 1

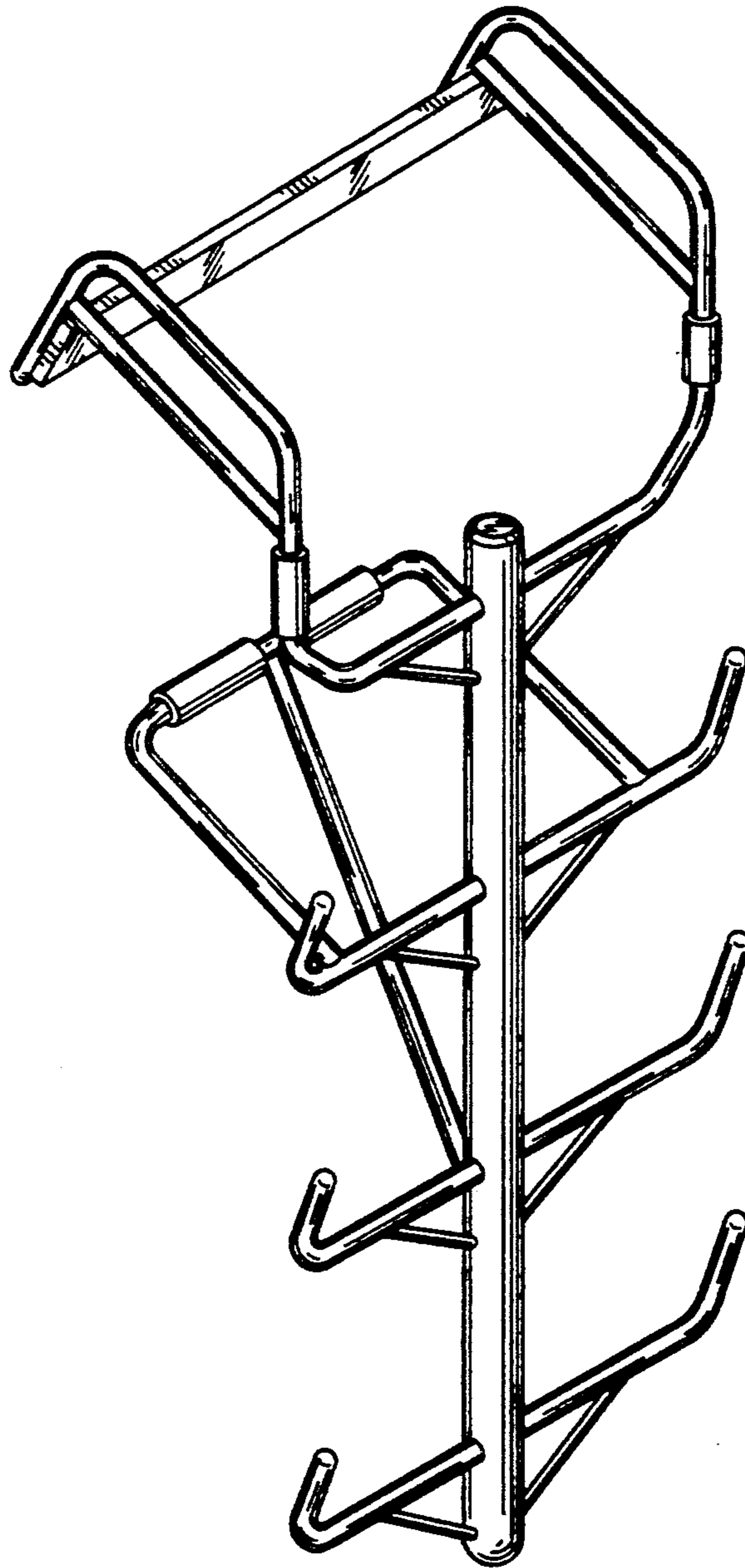

FIG. 2

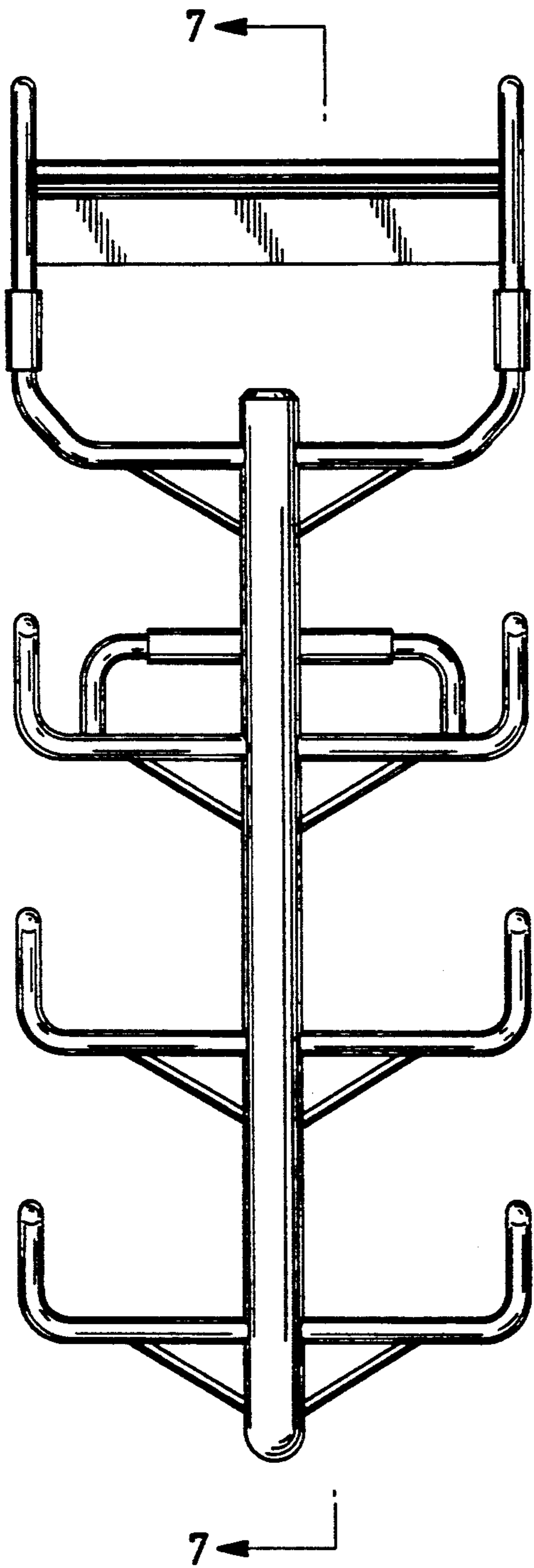

FIG. 3

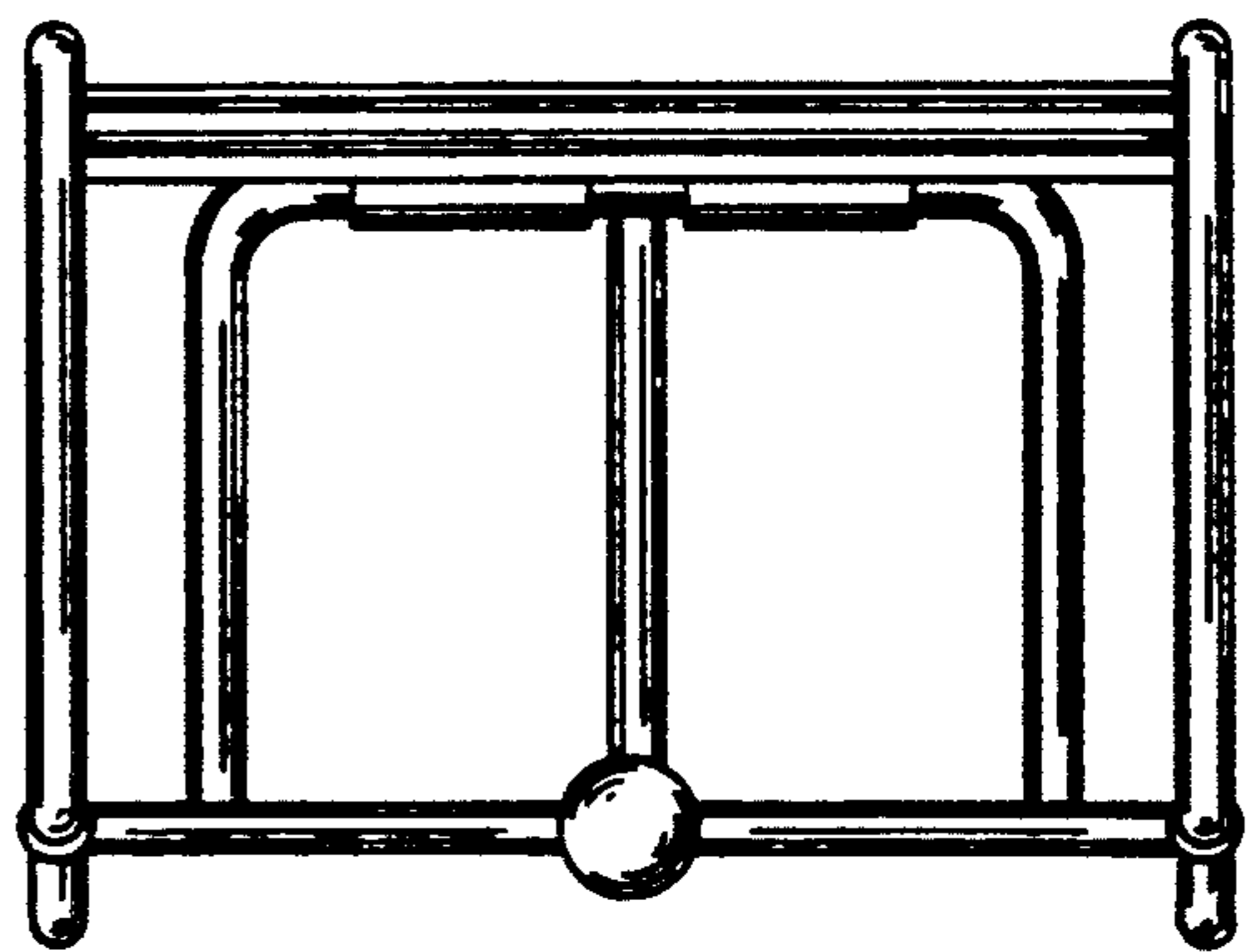

FIG. 4

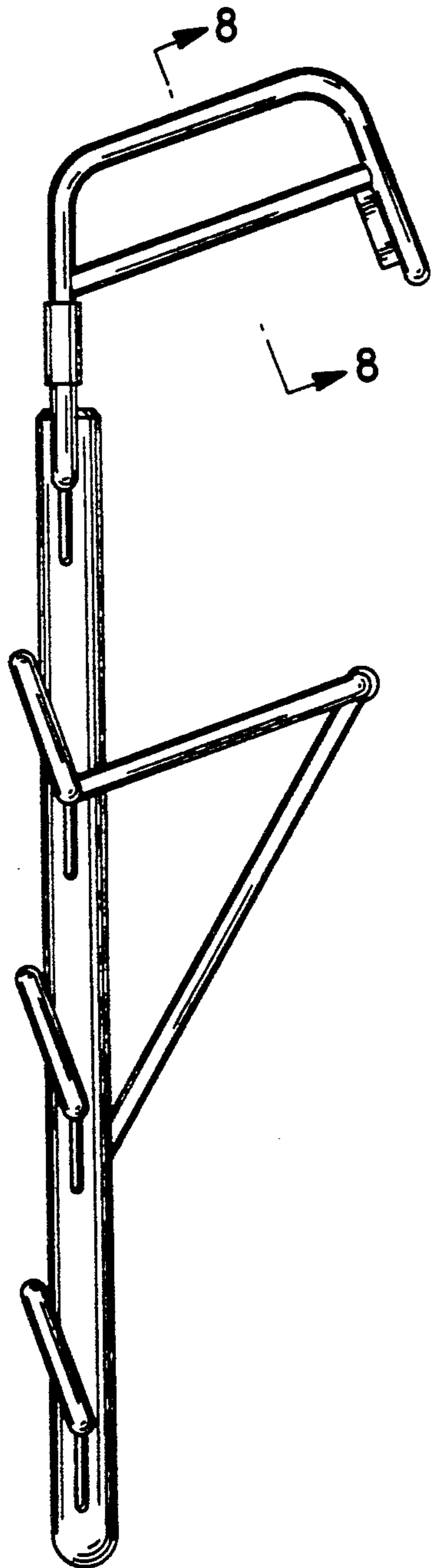

FIG. 5

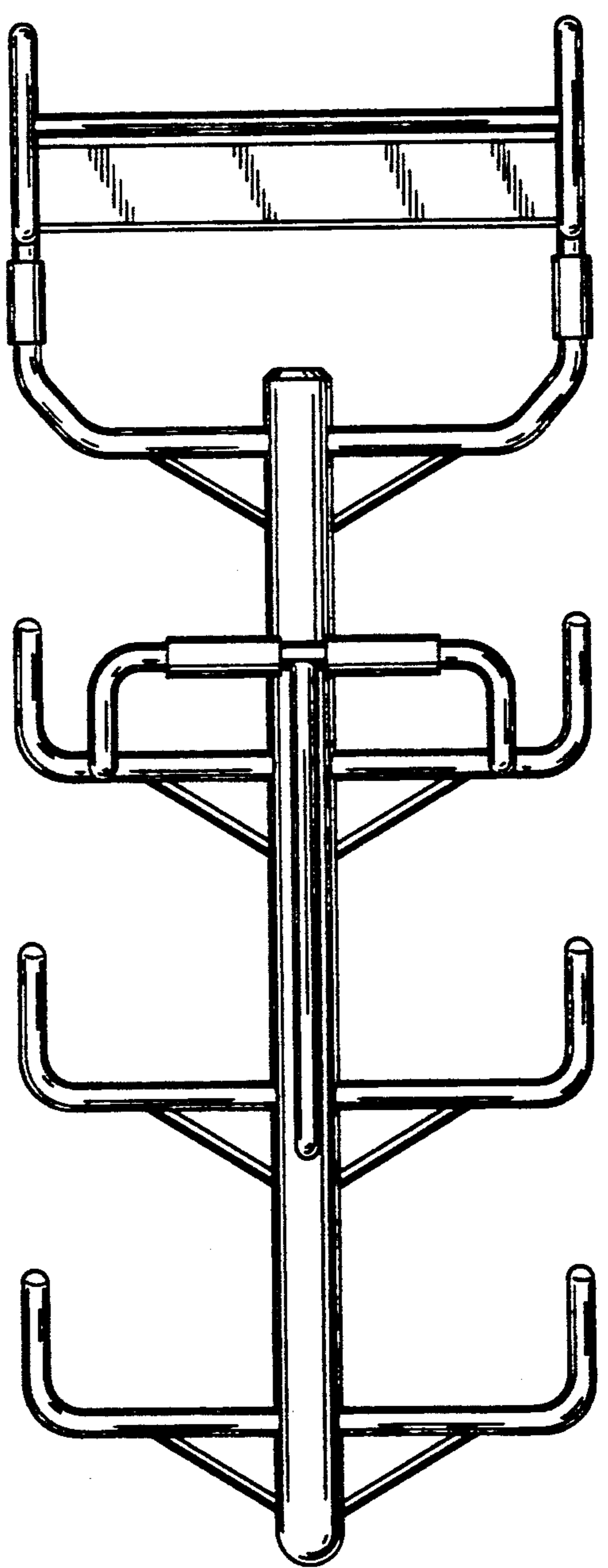

FIG. 6

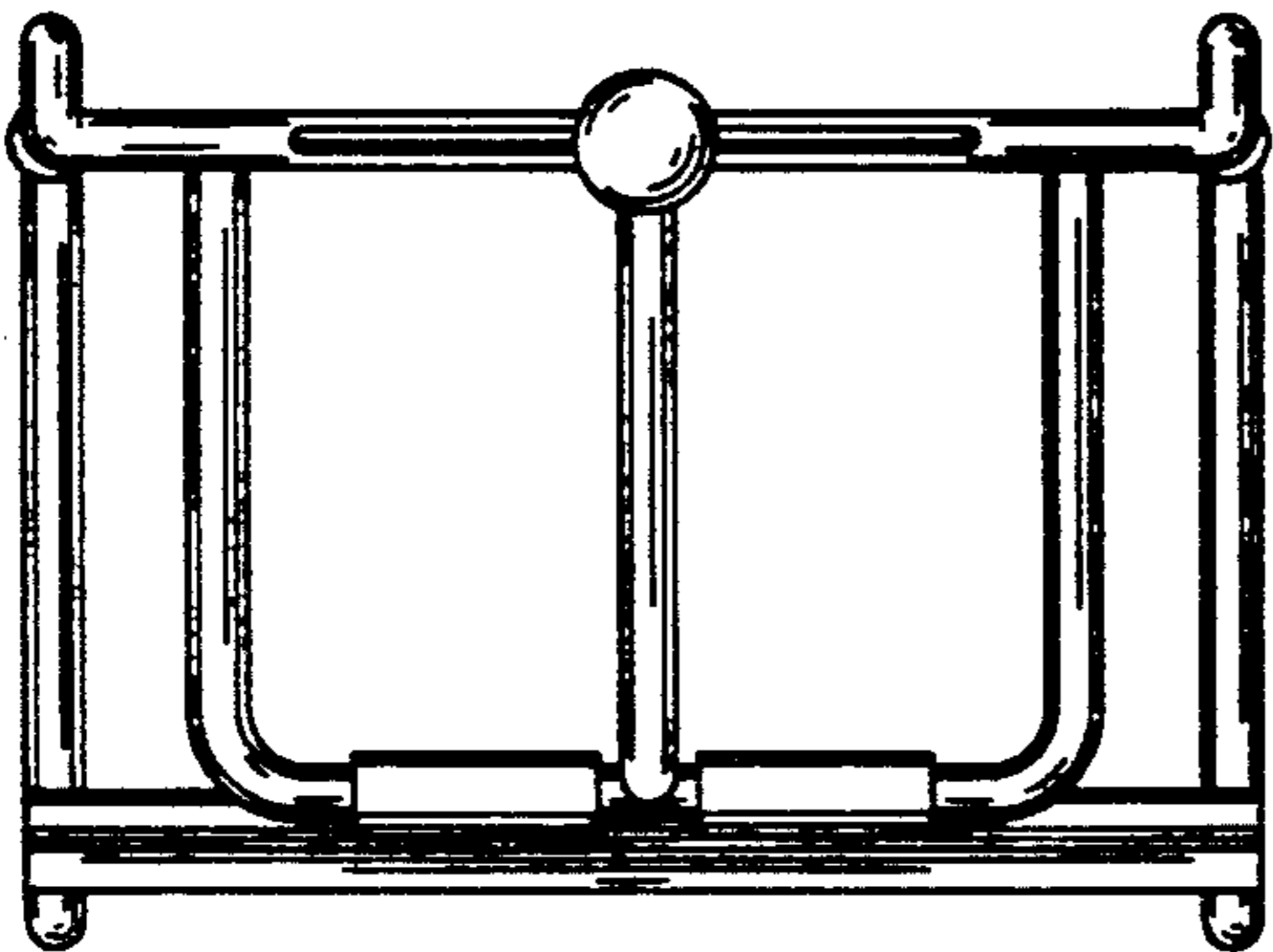

FIG. 7

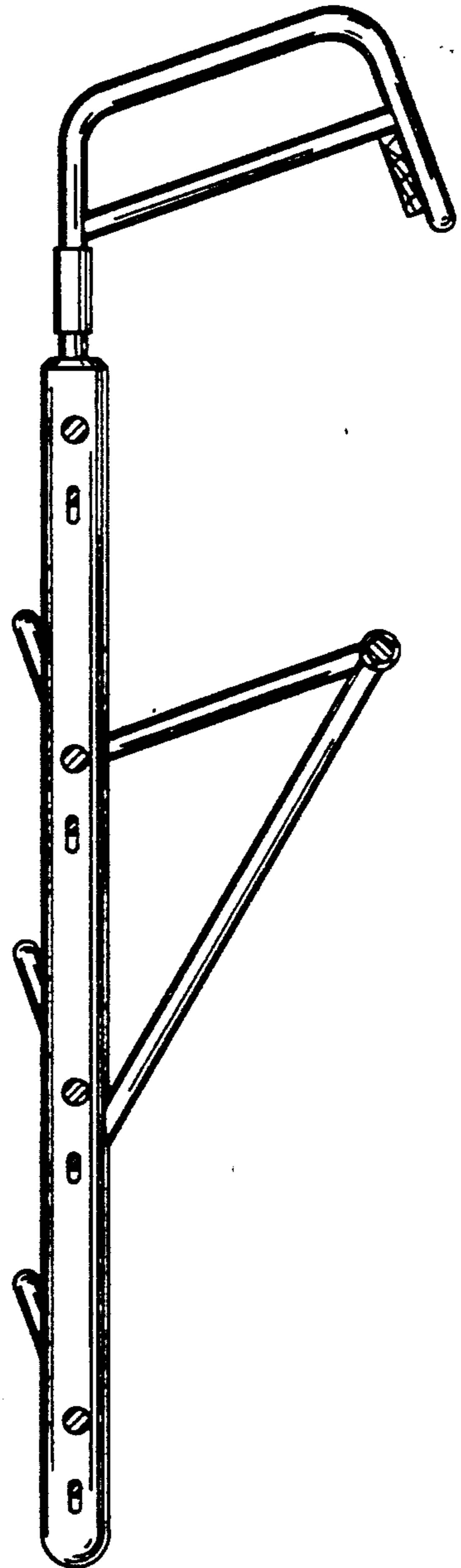

FIG. 8

