



US00D329419S

United States Patent [19]

[11] Patent Number: **Des. 329,419**

Thomas, Jr., deceased et al.

[45] Date of Patent: **** Sep. 15, 1992**

[54] **HYDRO SPEEDBOAT**

3,952,678 4/1976 Weston D12/311
4,944,240 7/1990 Morris 114/283

[76] Inventors: **William E. Thomas, Jr., deceased**, late of Alta Loma; by **Karen M. Thomas**, heir, 7184 Teak Way, Alta Loma, Calif. 91701

OTHER PUBLICATIONS

Trailer Boats, Jun. 1987, p. 31, "Spy Scoop" by Leisure Tech Boats.

[**] Term: **14 Years**

Primary Examiner—Kay H. Chin
Attorney, Agent, or Firm—John H. Crowe

[21] Appl. No.: **545,185**

[22] Filed: **Jun. 28, 1990**

[57] CLAIM

[52] U.S. Cl. **D12/309; D12/311; D12/300**

The ornamental design for a hydro speedboat, as shown and described.

[58] Field of Search **D12/300, 301, 304, 305, D12/307, 309, 310, 311; 114/270, 271, 56, 288, 289, 290, 291, 292**

DESCRIPTION

FIG. 1 is a top, front and right side perspective view of a hydro speedboat, showing my new design; FIG. 2 is a front elevational view thereof; FIG. 3 is a top plan view thereof; FIG. 4 is a right side elevational view thereof, the left side elevational view being a mirror image; FIG. 5 is a rear elevational view thereof; and, FIG. 6 is a bottom plan view thereof.

[56] References Cited

U.S. PATENT DOCUMENTS

D. 215,370	9/1969	Calkins	D12/311
D. 235,858	7/1975	Lyford, III	D12/311
D. 316,537	4/1991	Prystupa	D12/300
D. 317,747	6/1991	Riley	D12/300

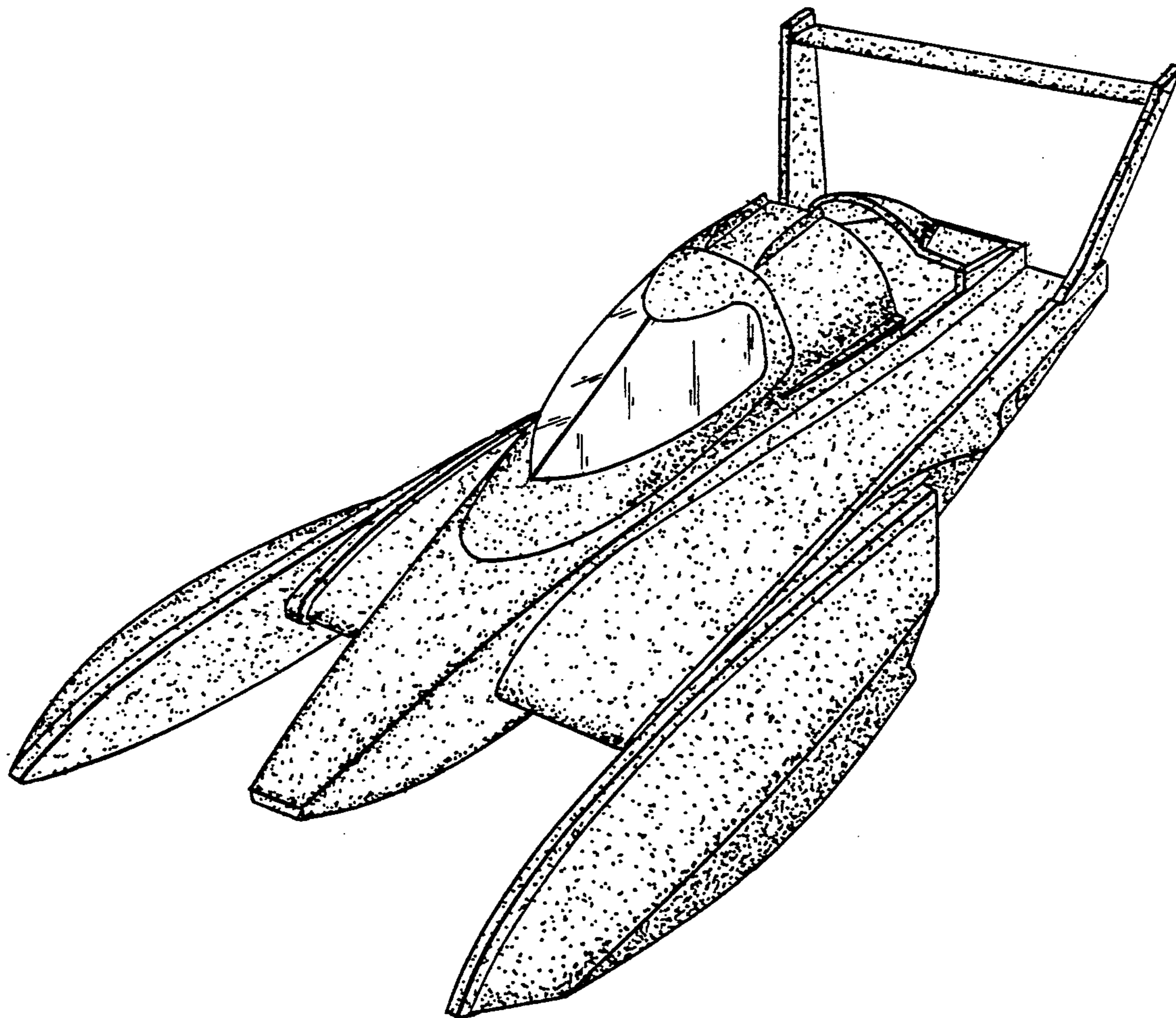

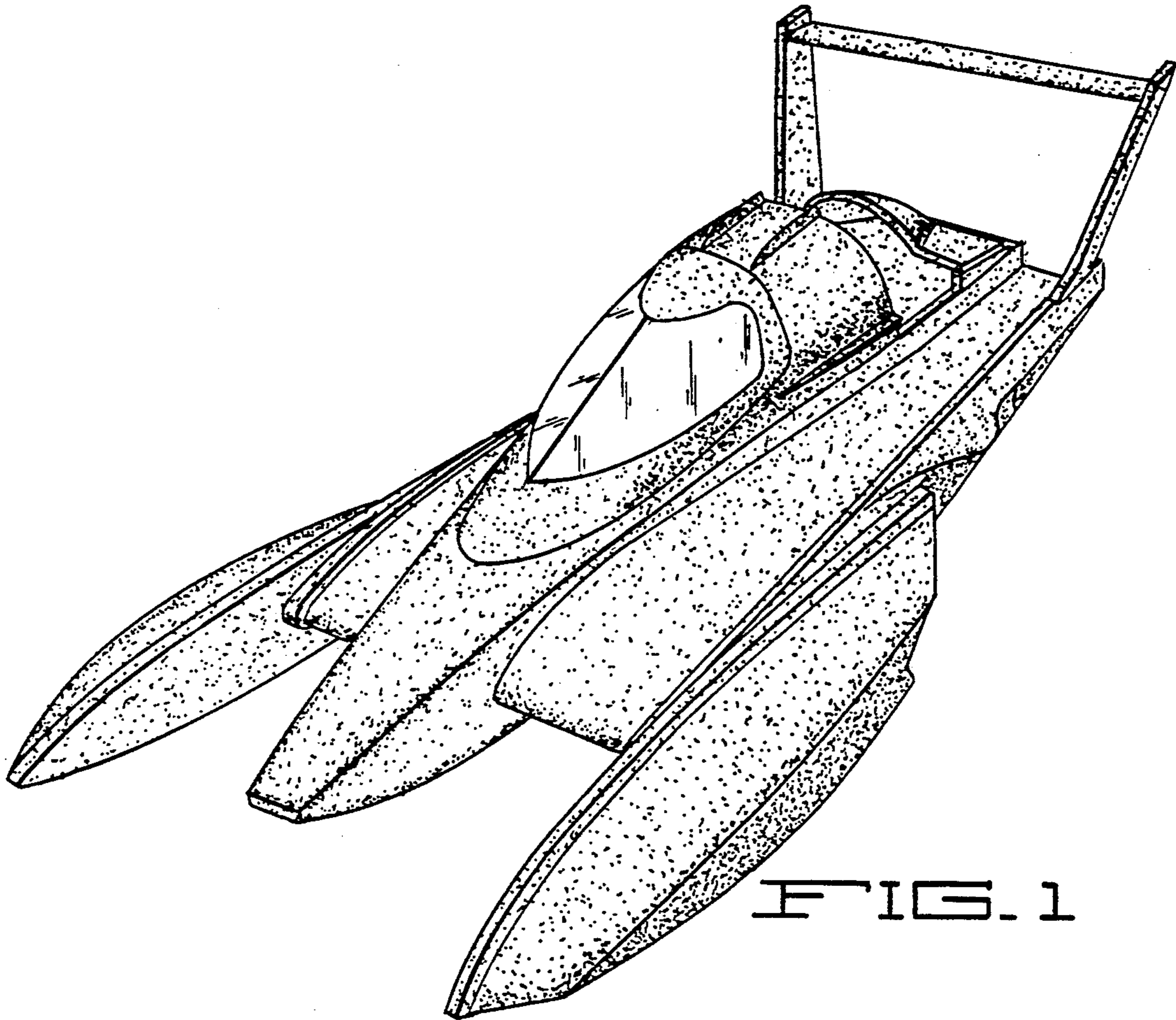

FIG. 1

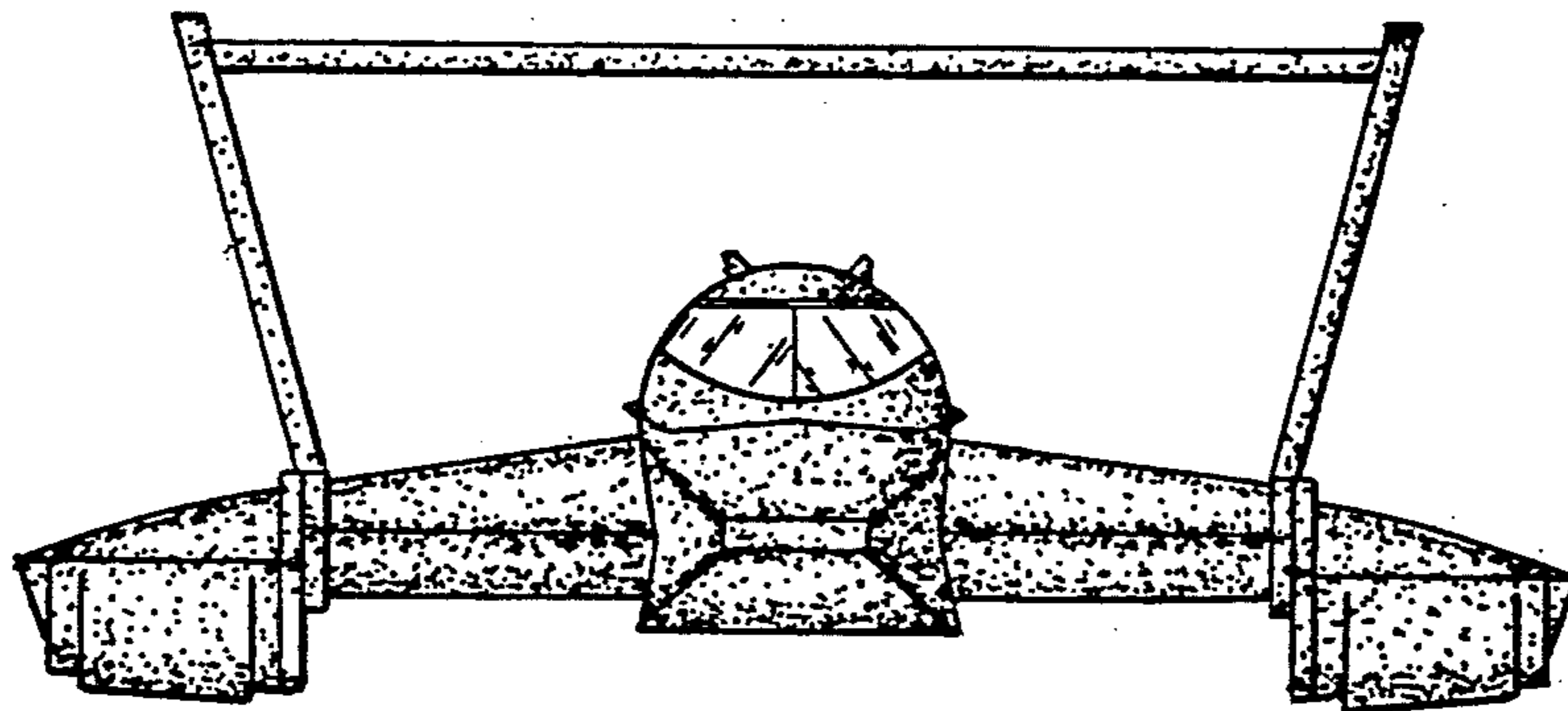

FIG. 2

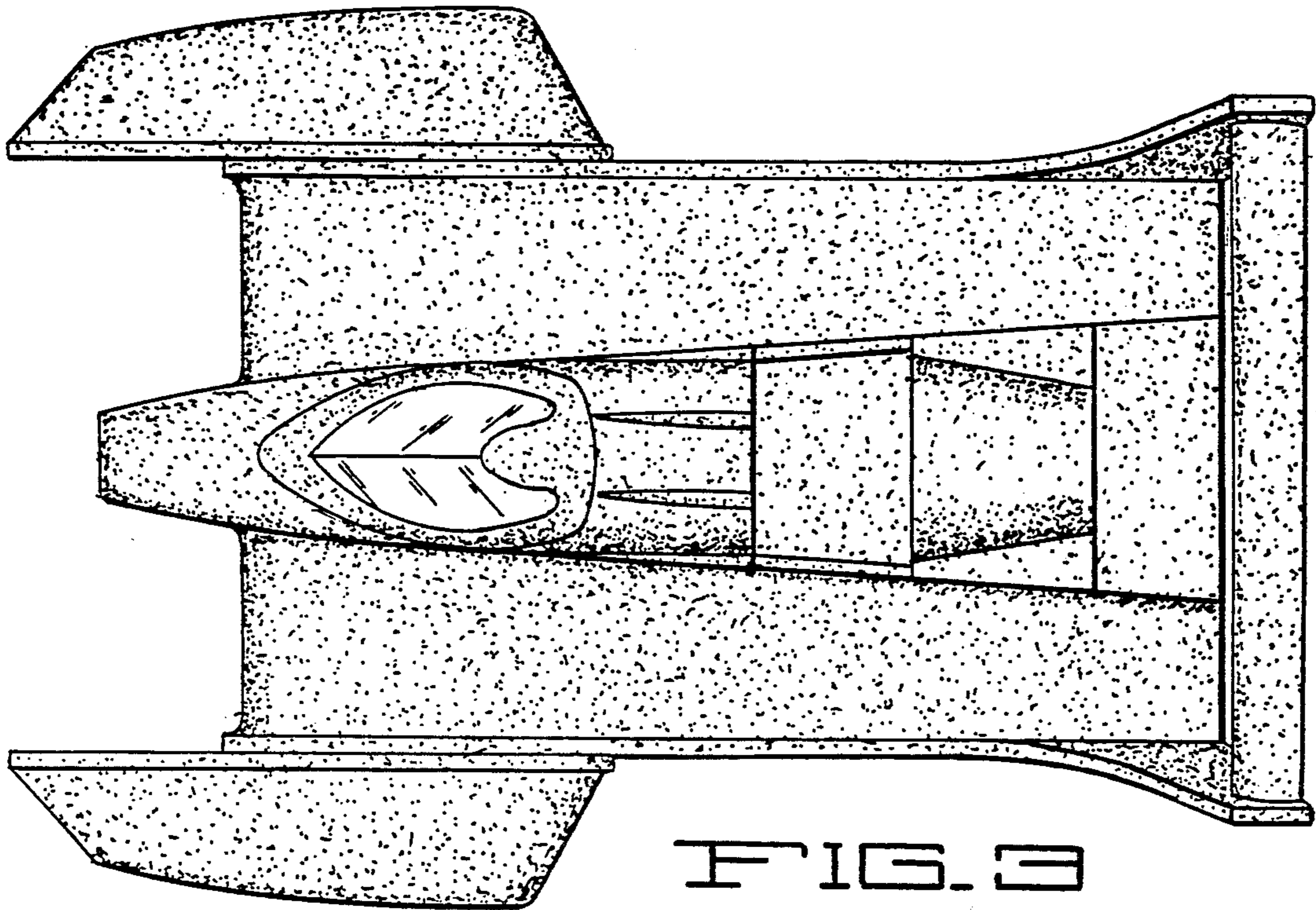

FIG. 3

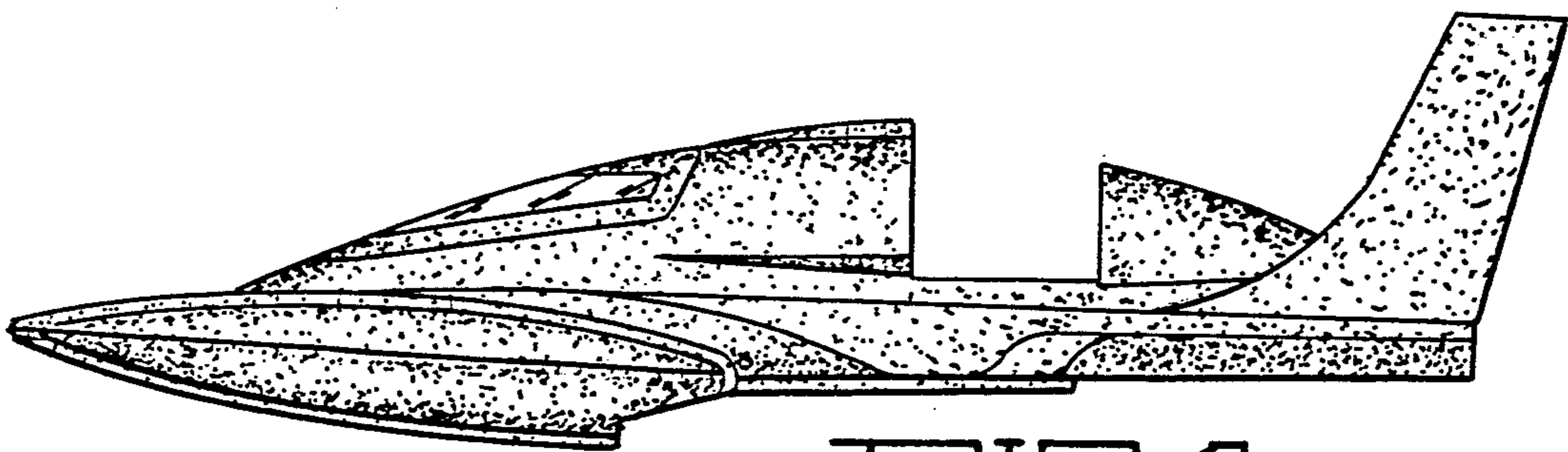

FIG. 4

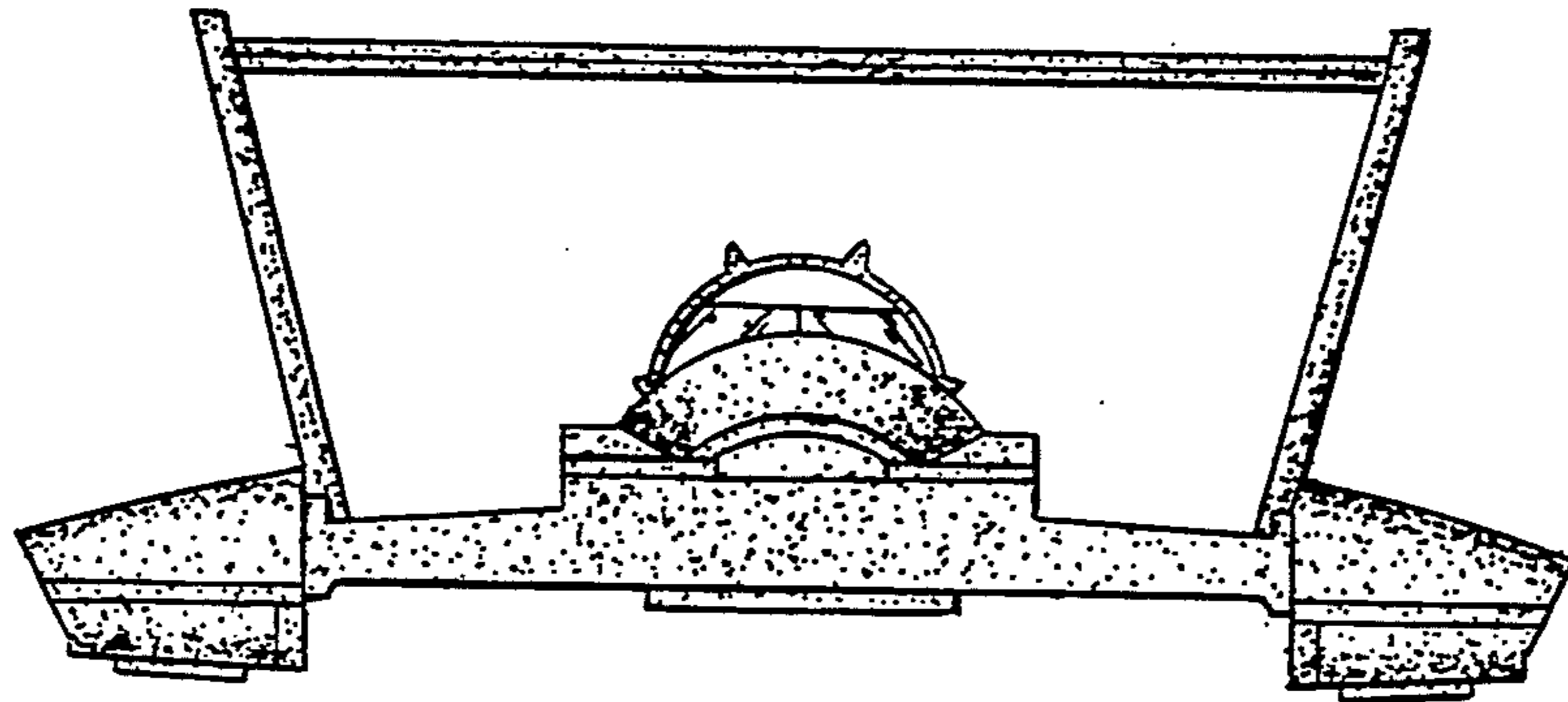

FIG. 5

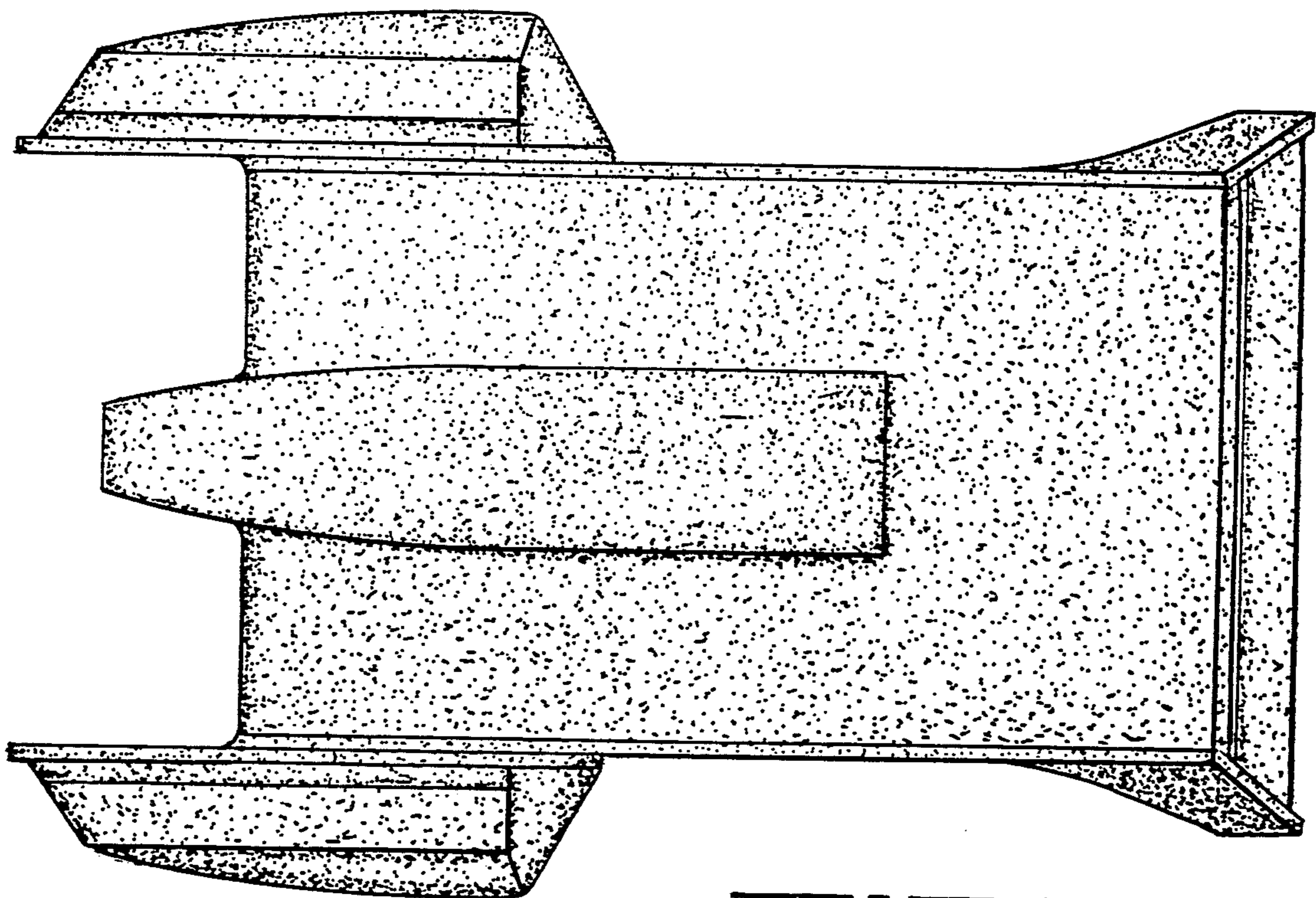

FIG. 6