



US00D329349S

United States Patent [19]

[11] Patent Number: Des. 329,349

Moreno

[45] Date of Patent: ** Sep. 15, 1992

[54] WALL MOUNTING BRACKET FOR A MUSICAL INSTRUMENT

[76] Inventor: John D. Moreno, 415 Old Ventura Ave., Oak View, Calif. 93022

[**] Term: 14 Years

[21] Appl. No.: 613,305

[22] Filed: Nov. 15, 1990

[52] U.S. Cl. D6/567

[58] Field of Search D6/512, 552-553, D6/567, 569, 572; D8/354, 363, 373; 211/13, 60.1, 64-65, 70.2, 70.8; 248/200, 224.1

[56] References Cited

U.S. PATENT DOCUMENTS

D. 217,225	4/1970	Fitzsimmons	D6/373
D. 242,966	1/1977	MacMillan	D6/553
D. 250,631	12/1978	Stephenson	D8/363 X
D. 300,406	3/1989	Bordian	D8/373 X
D. 308,782	6/1990	Getsi	D6/552 X
4,176,580	12/1979	Gallegos	248/224.1 X

Primary Examiner—Brian N. Vinson

[57] CLAIM

The ornamental design for a wall mounting bracket for a musical instrument, as shown and described.

DESCRIPTION

FIG. 1 is a top, front, and right side perspective view of a wall mounting bracket for a musical instrument showing my new design;

FIG. 2 is a top, front, and left side perspective view thereof, with the support arm shown rotated;

FIG. 3 is a reduced right side elevational view thereof, the left side being a mirror image of that shown;

FIG. 4 is a reduced front elevational view thereof;

FIG. 5 is a reduced top plan view thereof;

FIG. 6 is a reduced rear elevational view thereof;

FIG. 7 is a reduced bottom plan view thereof;

FIG. 8 is a reduced front elevational view thereof, with the support arm shown rotated;

FIG. 9 is a reduced right side elevational view thereof, with the support arm shown rotated;

FIG. 10 is a reduced left side elevational view thereof, with the support arm shown rotated;

FIG. 11 is a reduced top plan view thereof, with the support arm shown rotated; and,

FIG. 12 is a reduced bottom plan view thereof, with the support arm shown rotated.

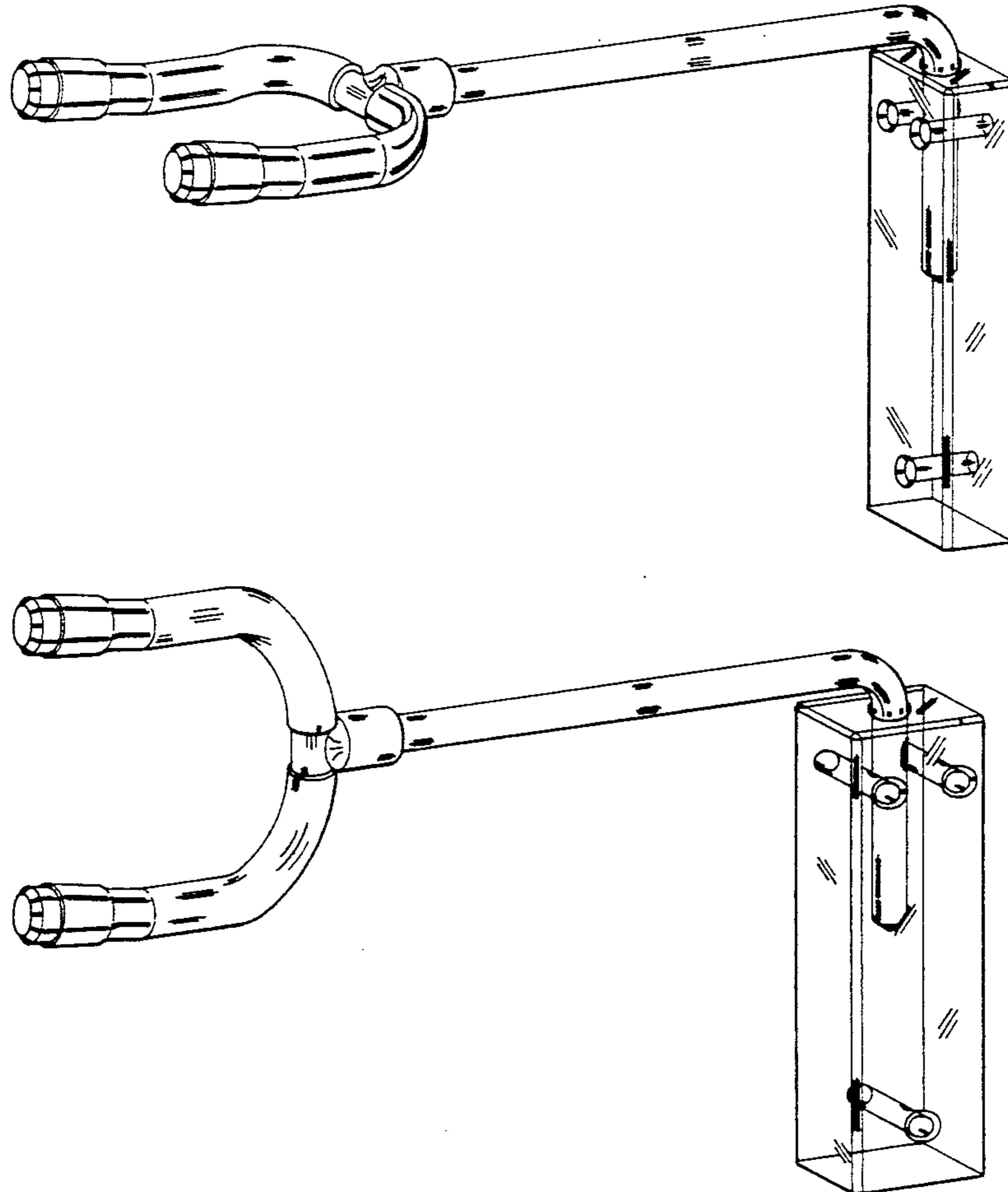

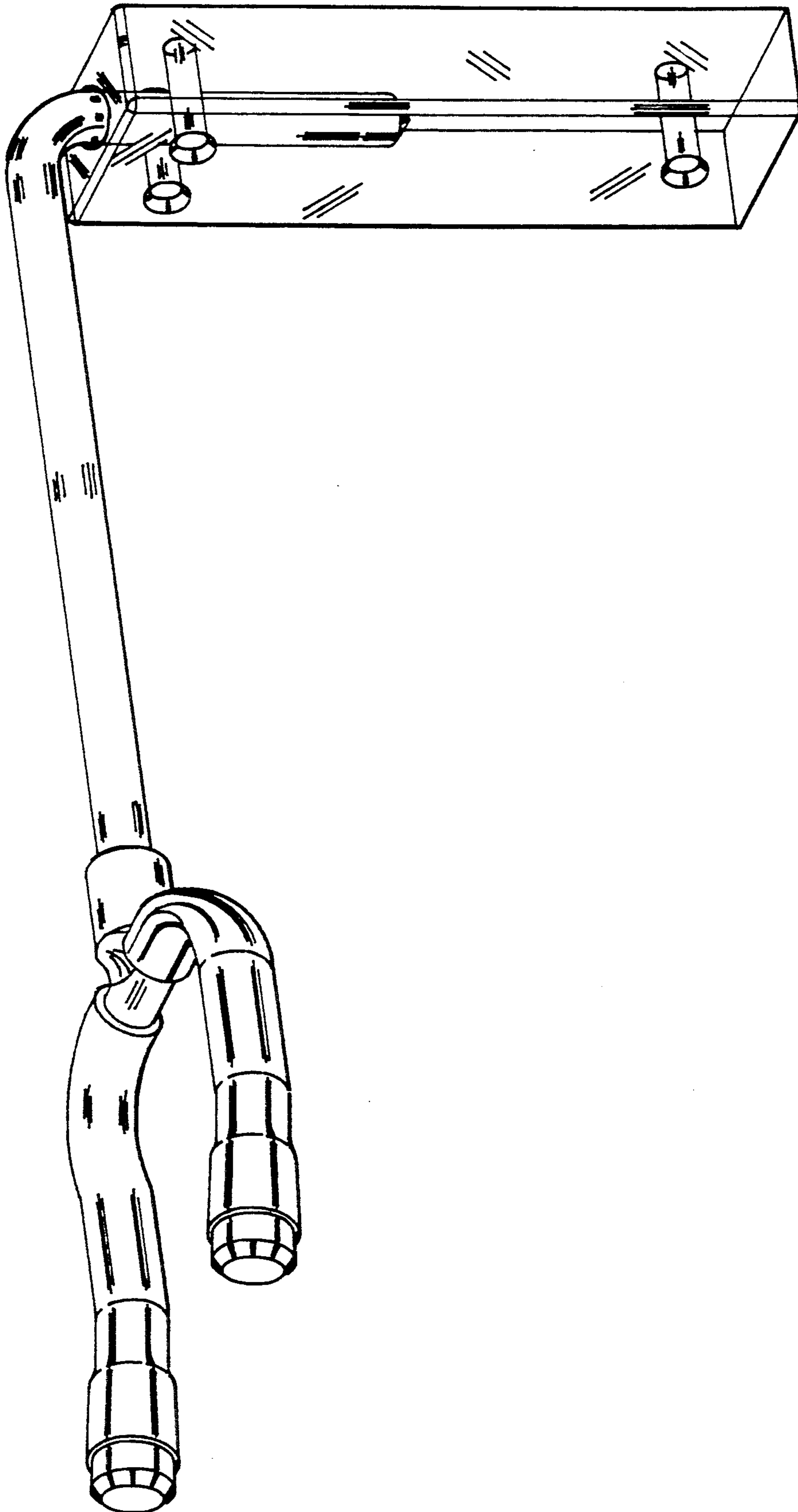

FIG. 1

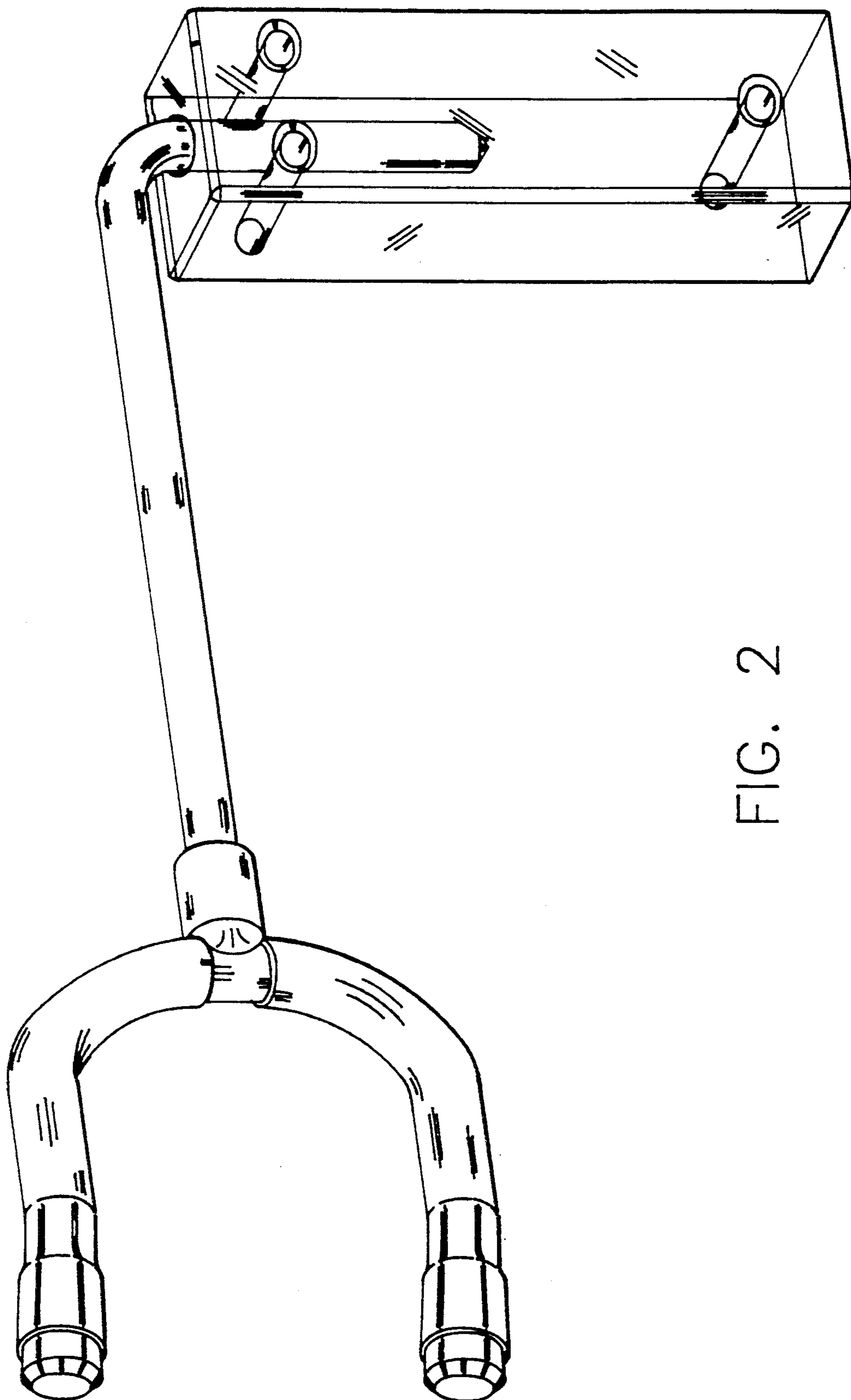

FIG. 2

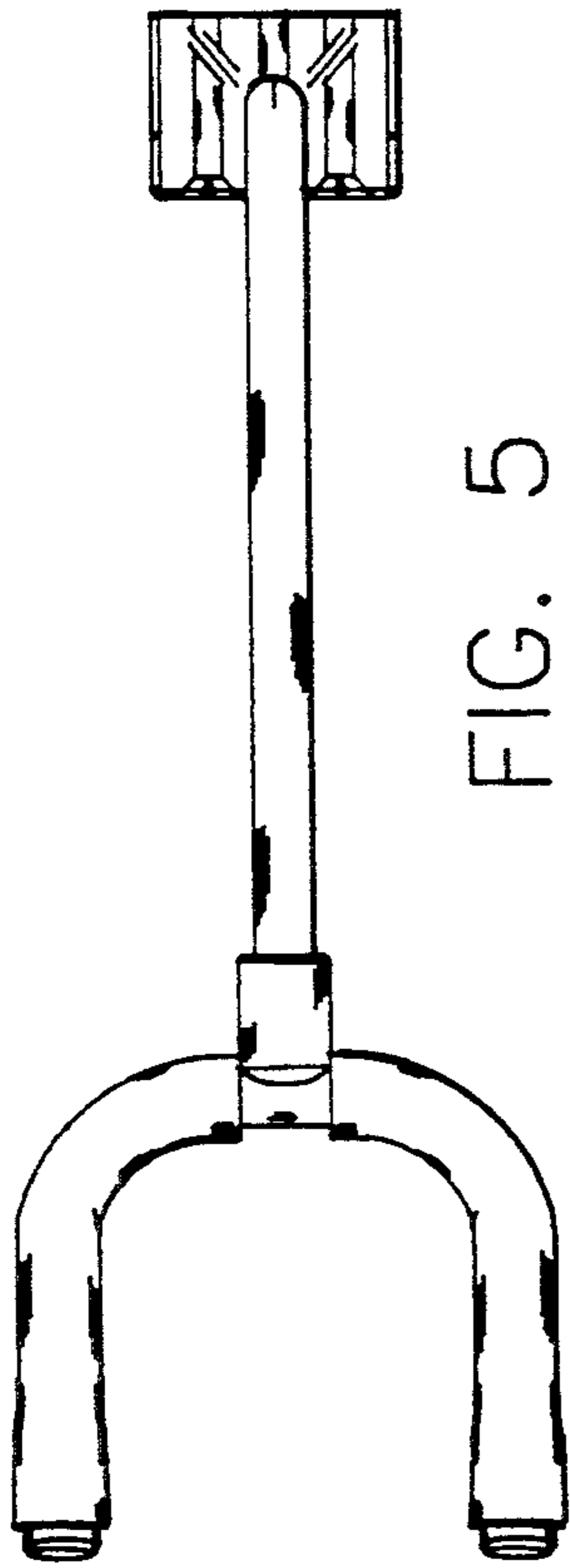

FIG. 5

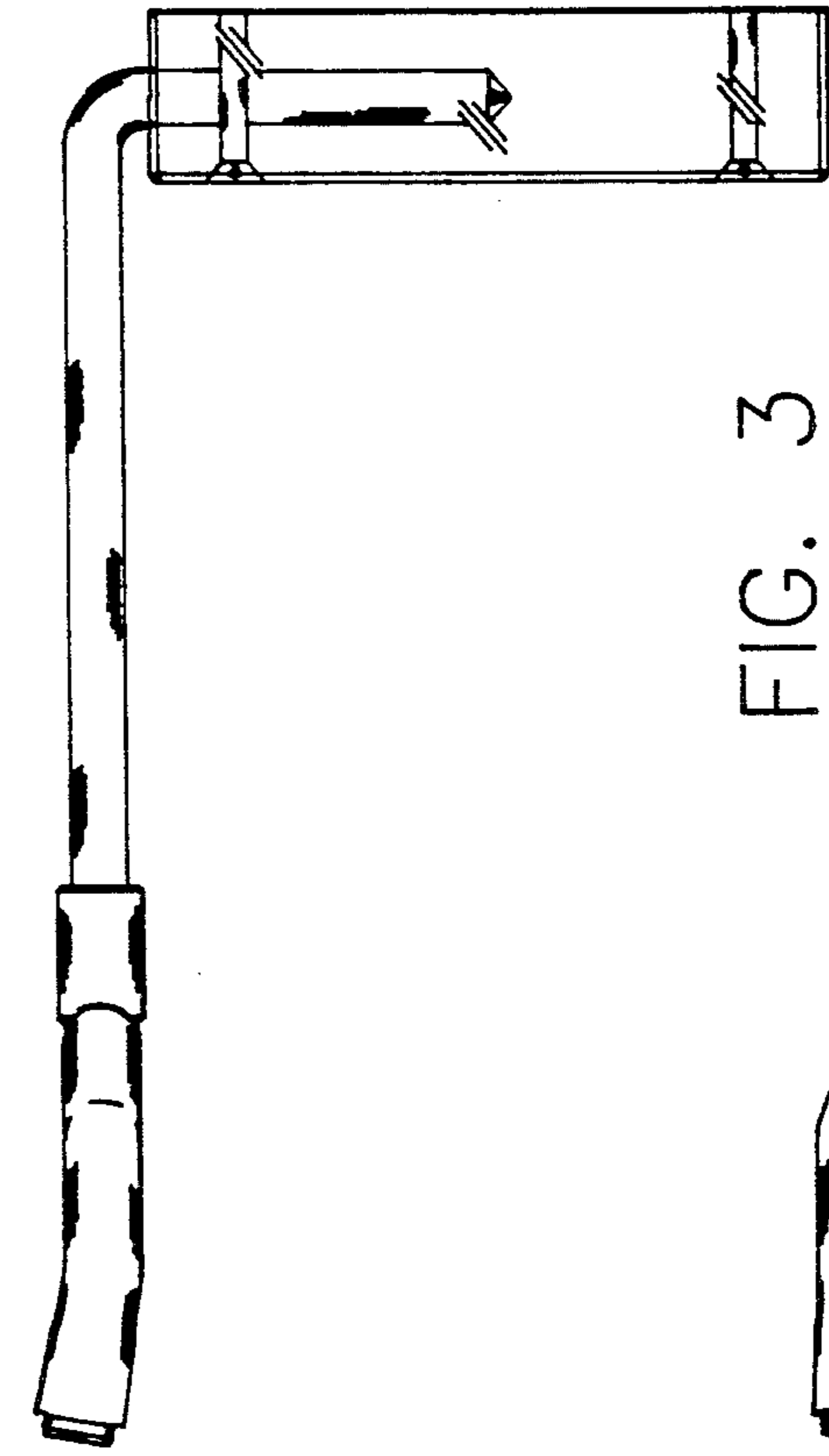

FIG. 3

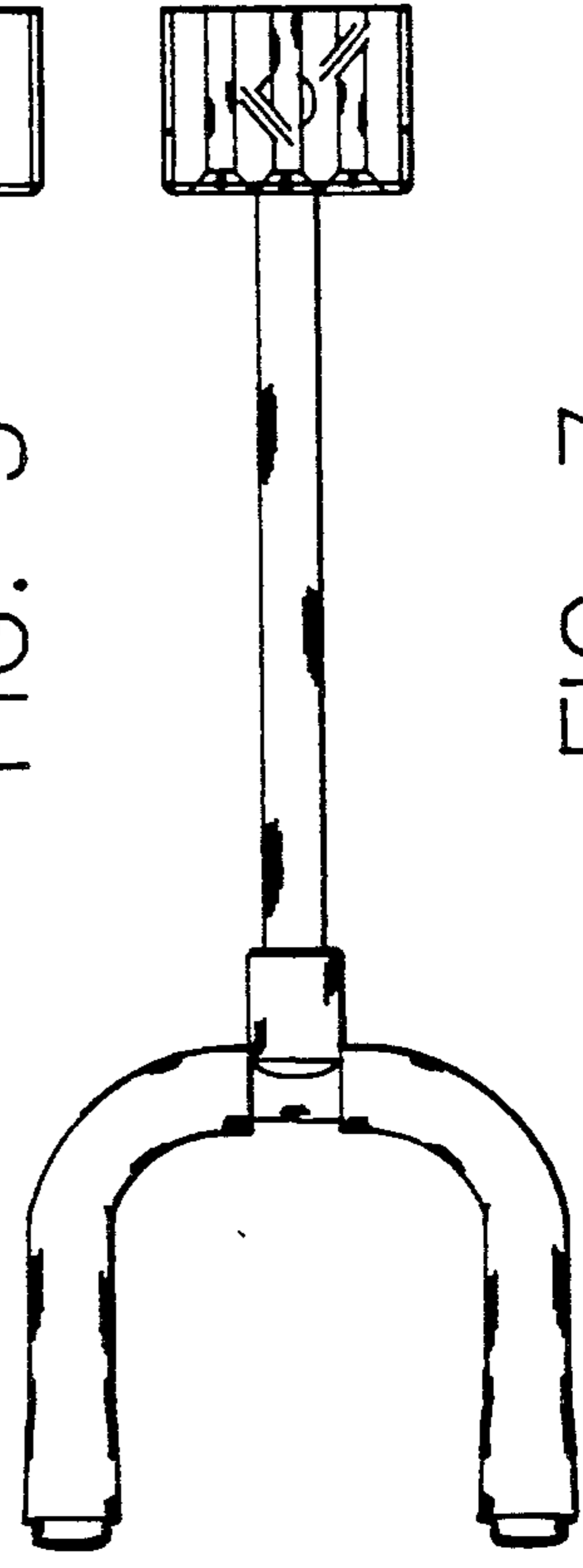

FIG. 7

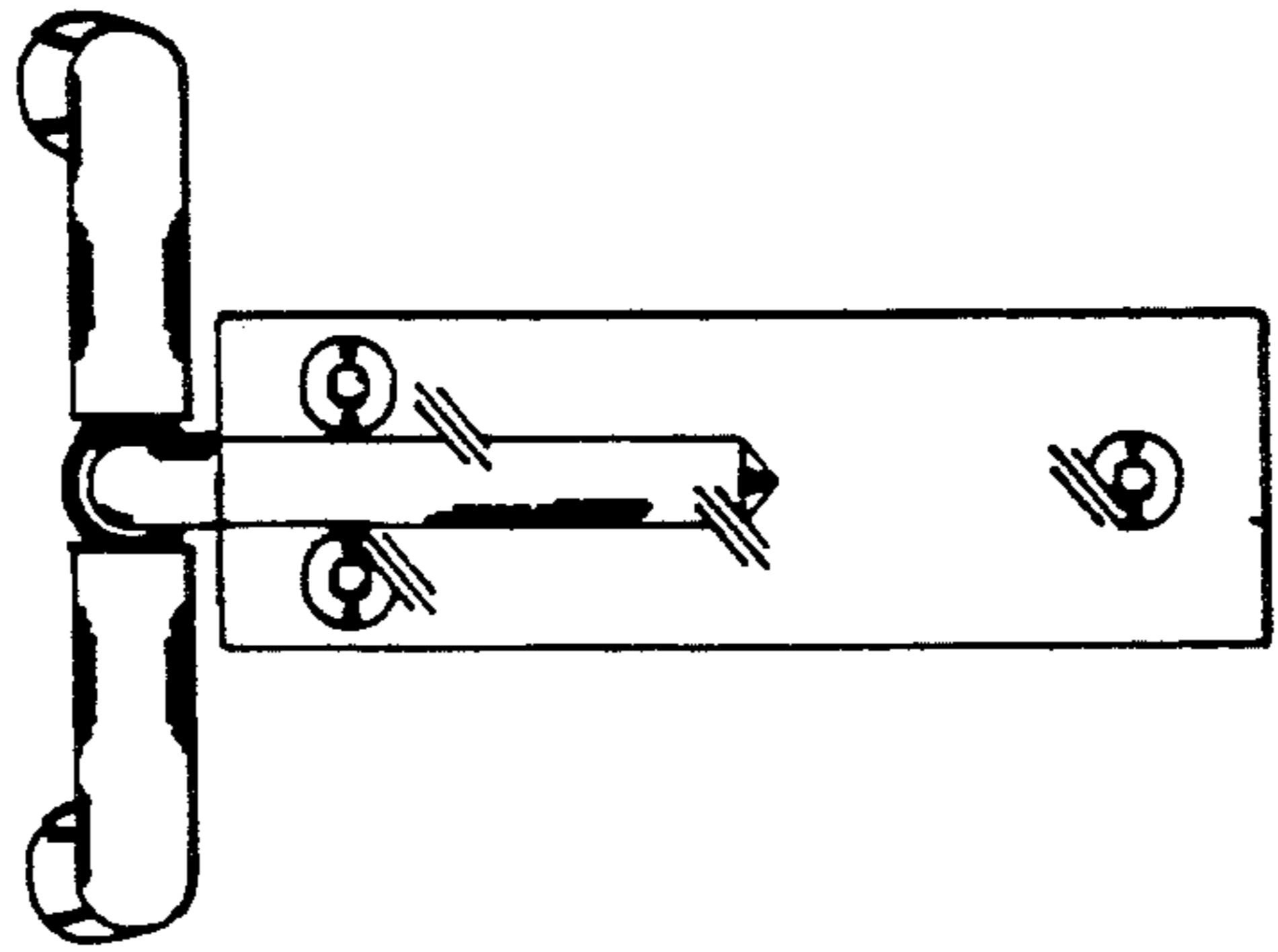

FIG. 6

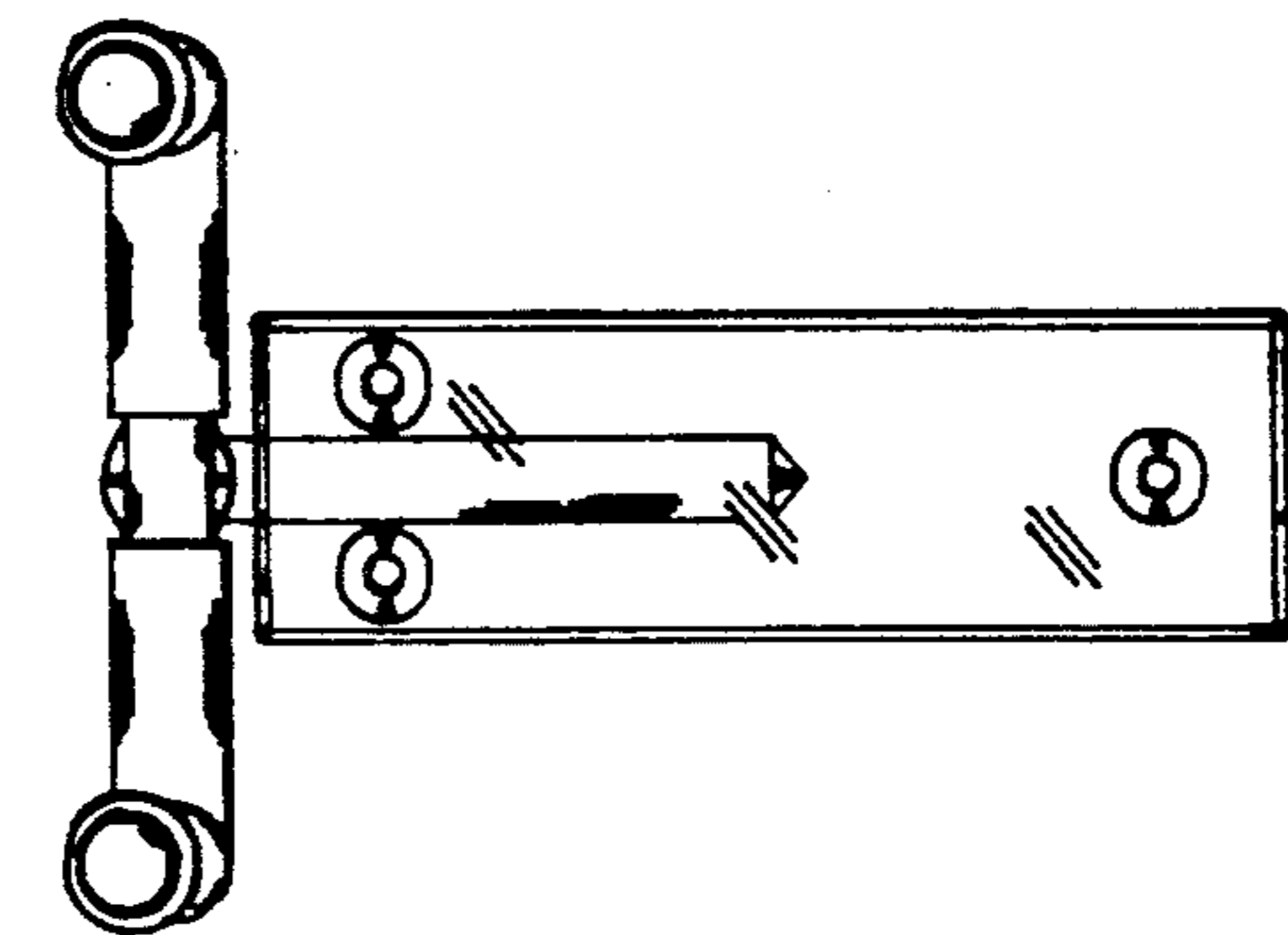

FIG. 4

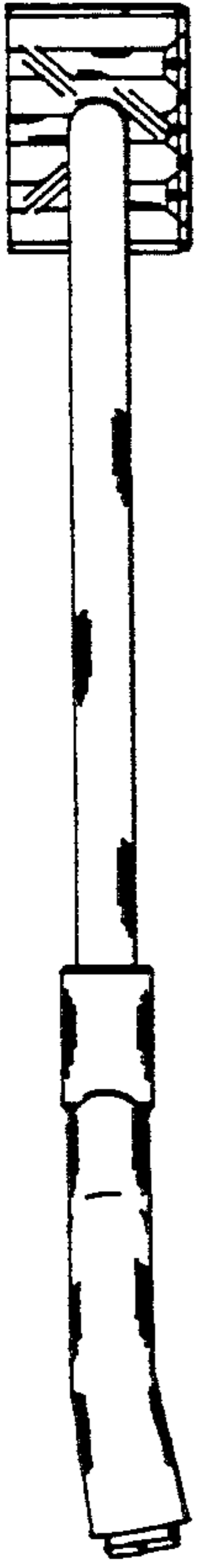

FIG. 11

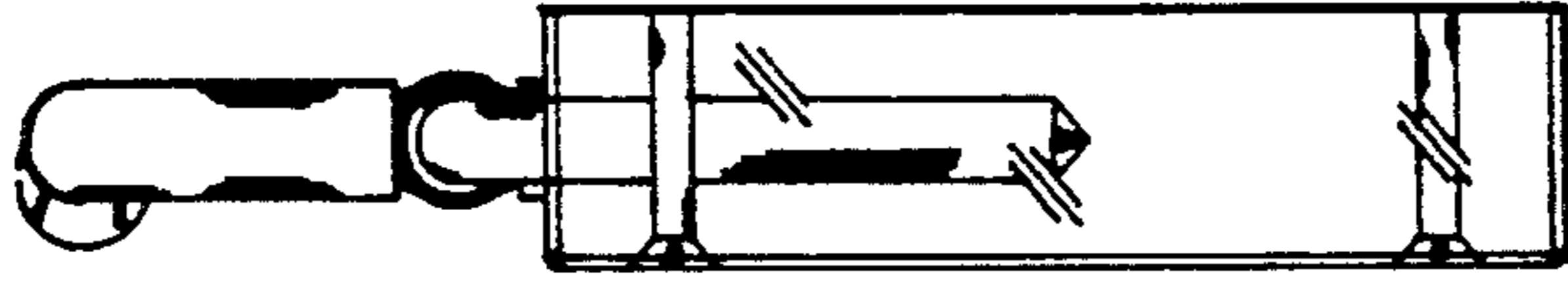

FIG. 9

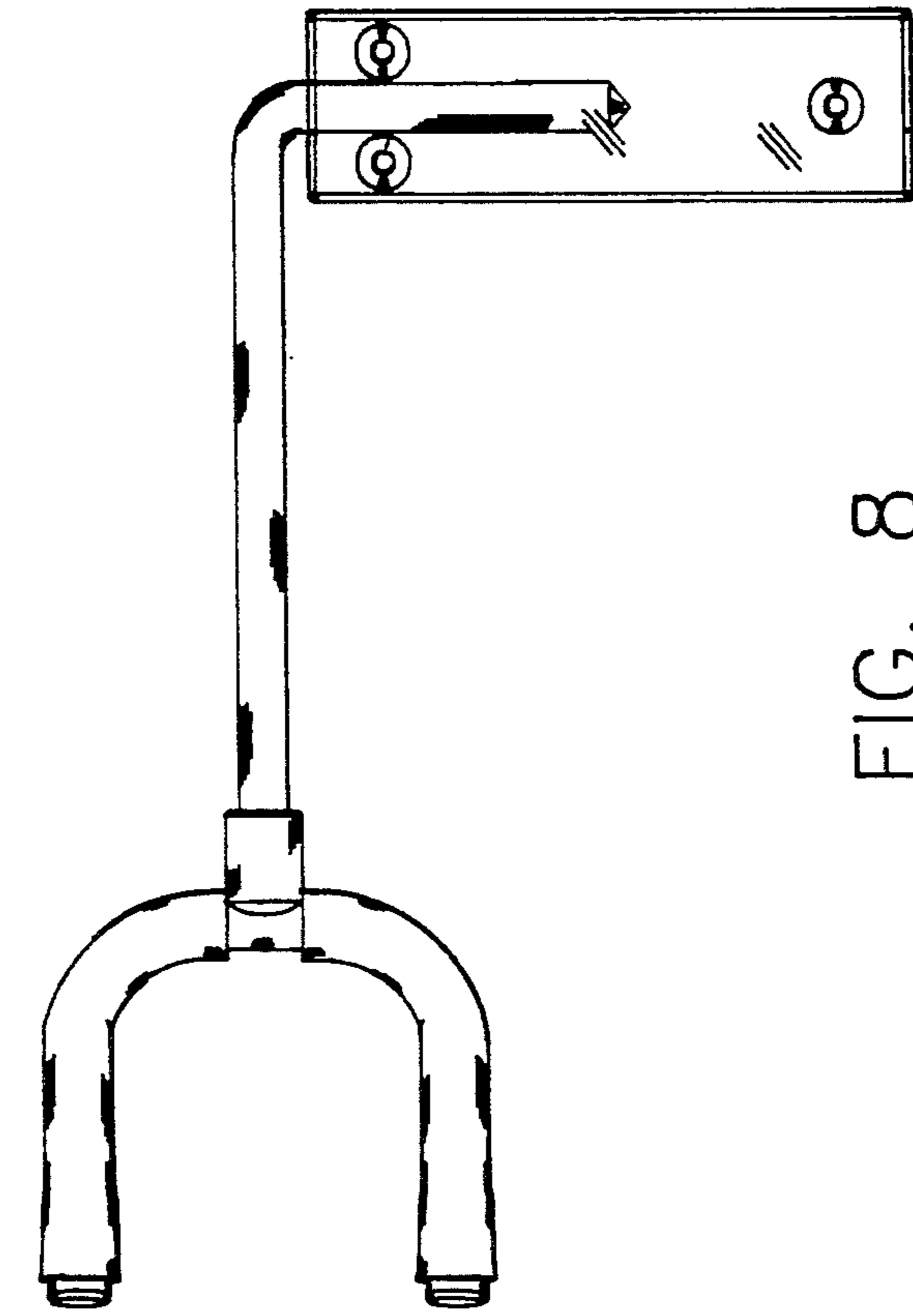

FIG. 8

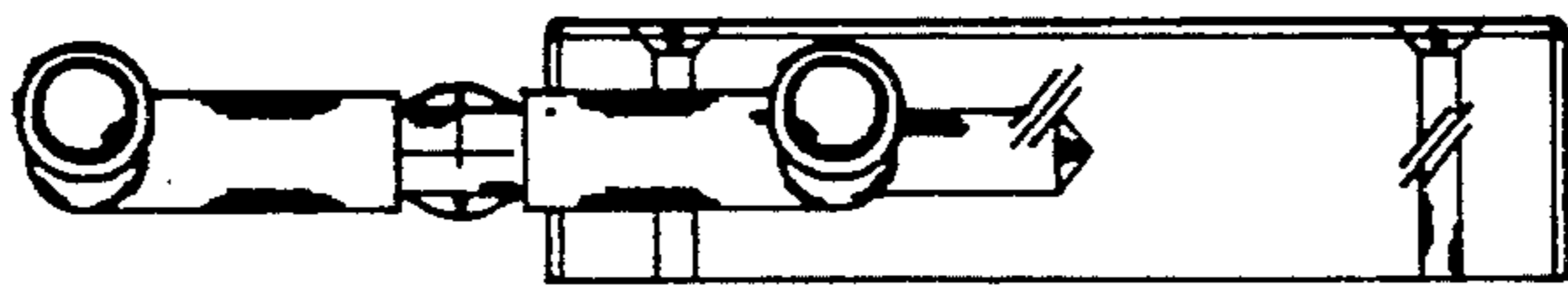

FIG. 10



FIG. 12