



US00D329212S

United States Patent [19]

[11] Patent Number: **Des. 329,212**

Murkett et al.

[45] Date of Patent: **** Sep. 8, 1992**

[54] **SPORTS CAR BODY**

[75] Inventors: **Stephen Murkett, Gerlingen; Harm Lagaay, Marbach**, both of Fed. Rep. of Germany

[73] Assignee: **Porsch AG, Fed. Rep. of Germany**

[**] Term: **14 Years**

[21] Appl. No.: **487,800**

[22] Filed: **Mar. 2, 1990**

[30] **Foreign Application Priority Data**

Sep. 5, 1989 [DE] Fed. Rep. of Germany M8906219.1

[52] U.S. Cl. **D12/91**

[58] Field of Search **D12/90, 91; 296/185**

[56] **References Cited**

U.S. PATENT DOCUMENTS

D. 199,433 10/1964 Porsche, Jr. D12/91
D. 313,578 1/1991 Dimson D12/91

OTHER PUBLICATIONS

Motor Trend, Jan. 1989, p. 75, Porsche 959.

Primary Examiner—James M. Gandy

Attorney, Agent, or Firm—Evenson, Wands, Edwards, Lenahan & McKeown

[57] **CLAIM**

The ornamental design for a sports car body, as shown and described.

DESCRIPTION

FIG. 1 is a front perspective view of a sports car body showing our new design with the removable roof panel omitted;

FIG. 2 is a perspective view of the front and left side thereof;

FIG. 3 is a left side elevational view thereof, the right side being substantially a mirror image of that shown;

FIG. 4 is a top, left side perspective view thereof;

FIG. 5 is a fragmentary top, left side perspective view thereof with the removable roof panel in place;

FIG. 6 is a fragmentary perspective view similar to FIG. 5 with the removable roof panel and rear window omitted;

FIG. 7 is a perspective view of the rear and left side thereof with the removable roof panel and rear window omitted;

FIG. 8 is a fragmentary perspective view of the rear and left side thereof with the removable roof panel in place;

FIG. 9 is a fragmentary perspective view similar to FIG. 8 with the center portion of the removable roof panel omitted;

FIG. 10 is a fragmentary perspective view similar to FIG. 8 with entire removable roof panel omitted;

FIG. 11 is a rear perspective view thereof with the removable roof panel in place;

FIG. 12 is a fragmentary rear perspective view thereof with the removable roof panel and rear window omitted;

FIG. 13 is a fragmentary rear perspective view of FIG. 11 with the center portion of the removable roof panel omitted;

FIG. 14 is a fragmentary rear perspective view of FIG. 11 with the entire removable roof panel omitted;

FIG. 15 is an enlarged fragmentary side elevational view of the front portion thereof; and,

FIG. 16 is an enlarged fragmentary side elevation view of the rear portion thereof.

The broken line showing of environmental structure in FIGS. 1, 2, 3, 4, 6, 7, 12, 15, and 16 of the drawing is for illustrative purposes only and forms no part of the claimed design.

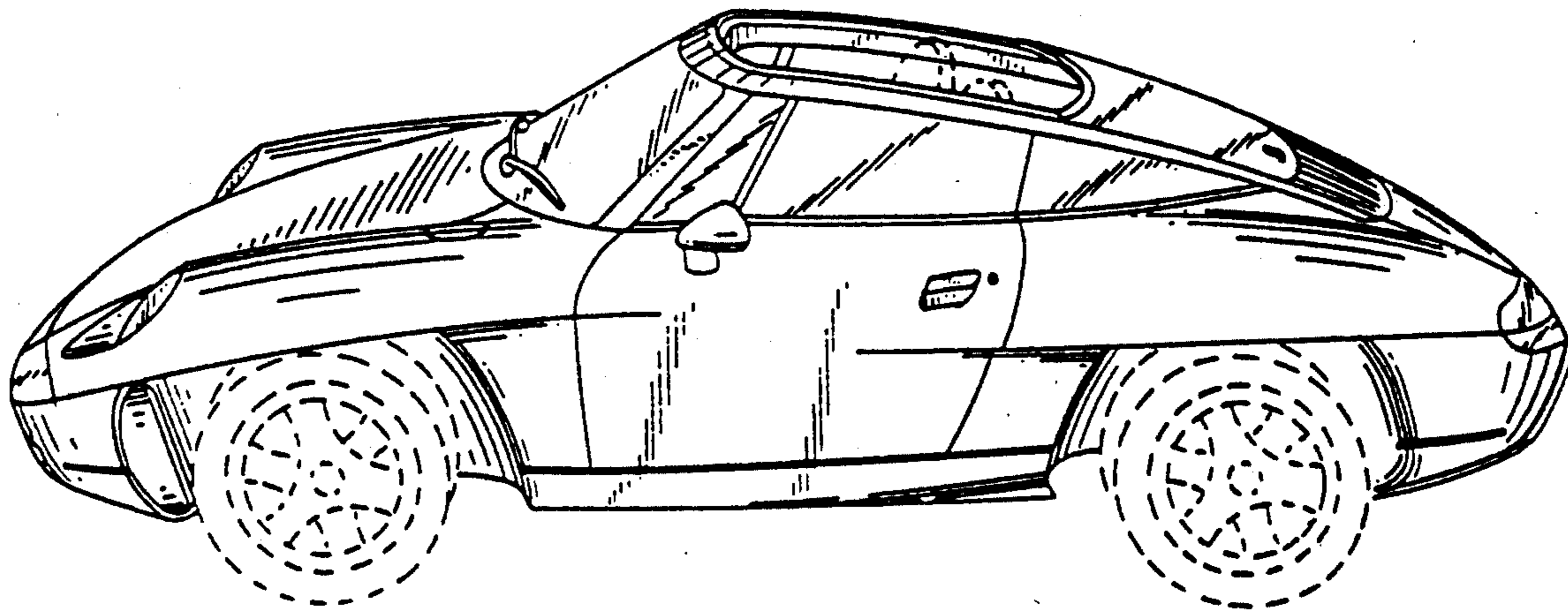

FIG. 1

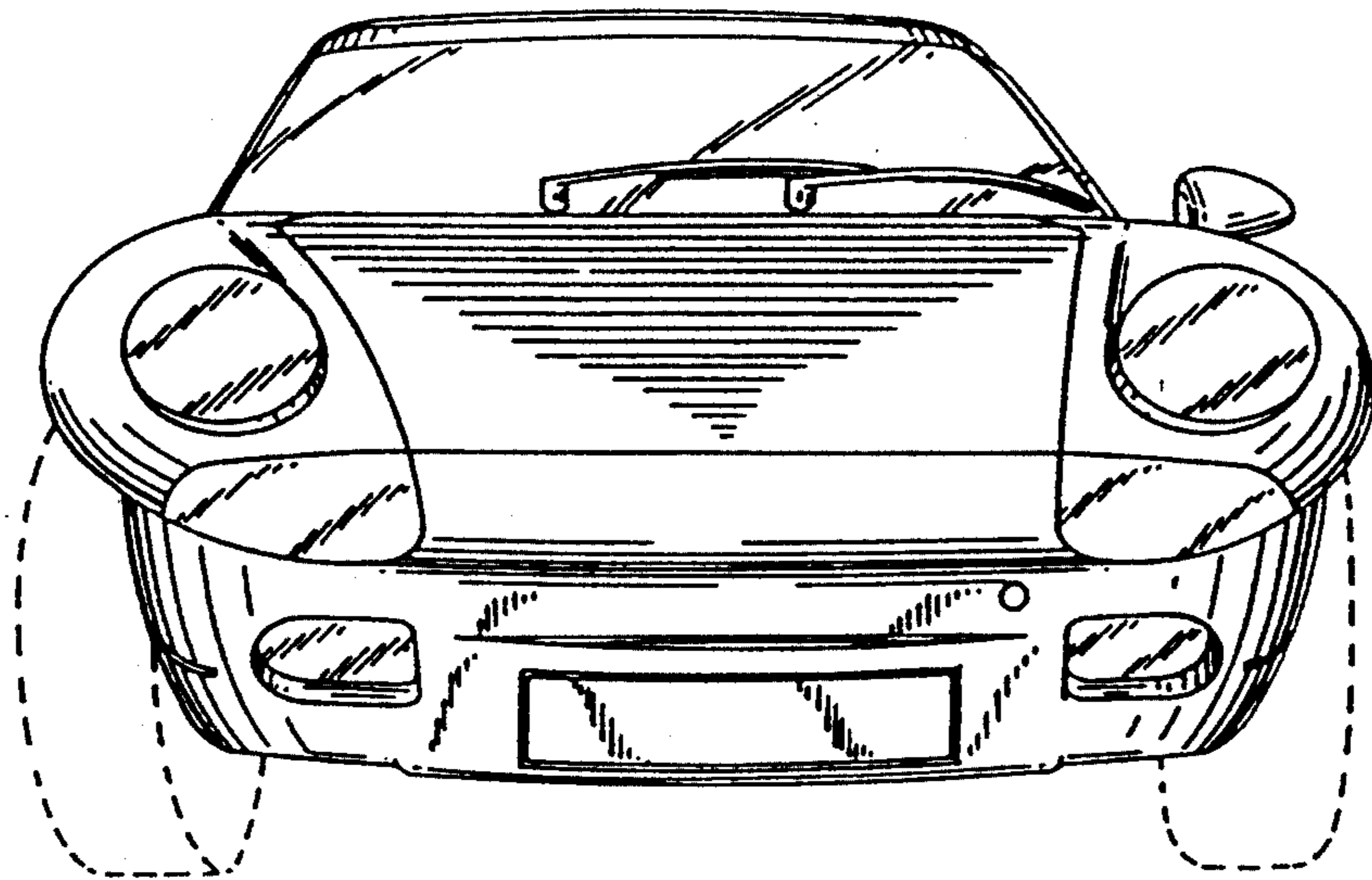

FIG. 2

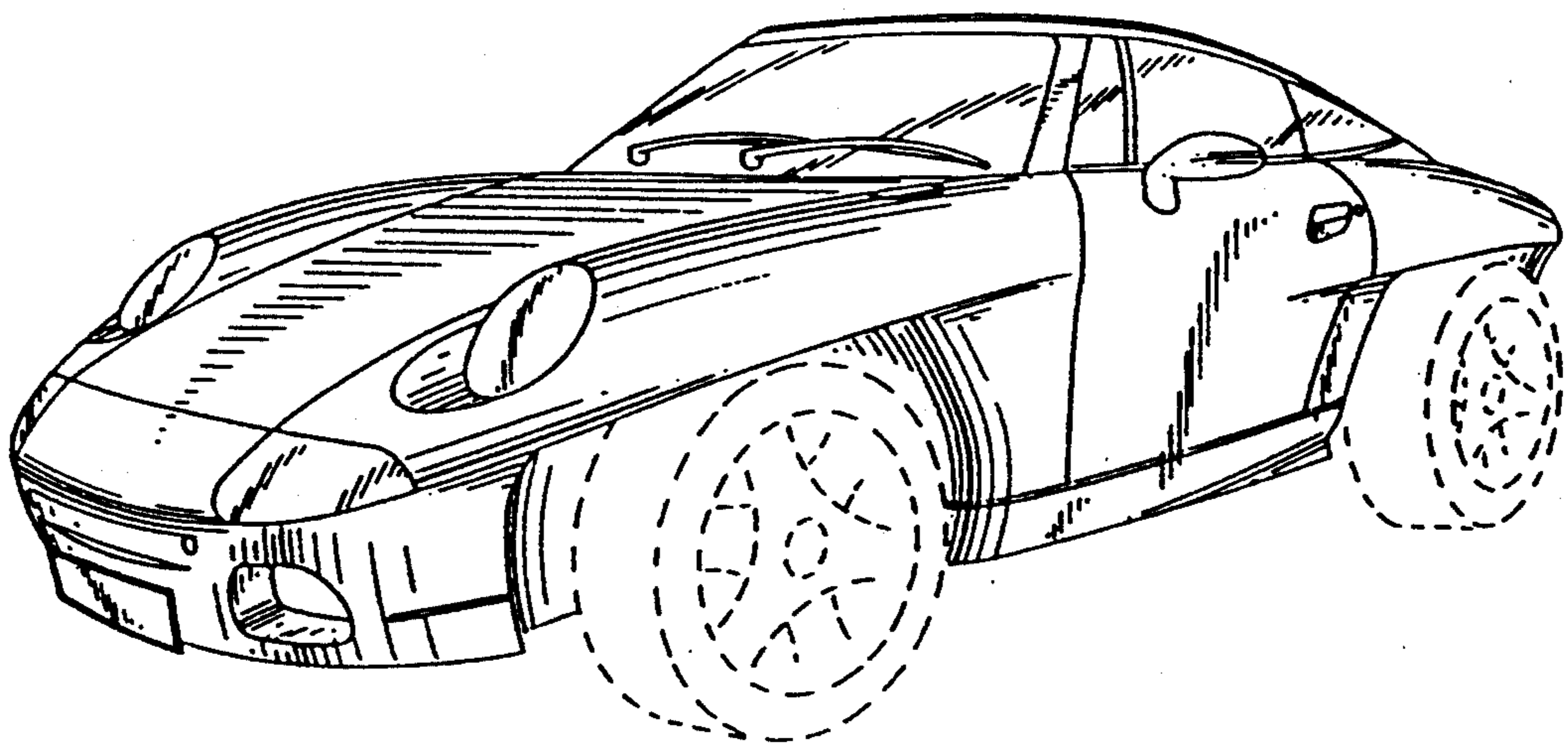

FIG. 3

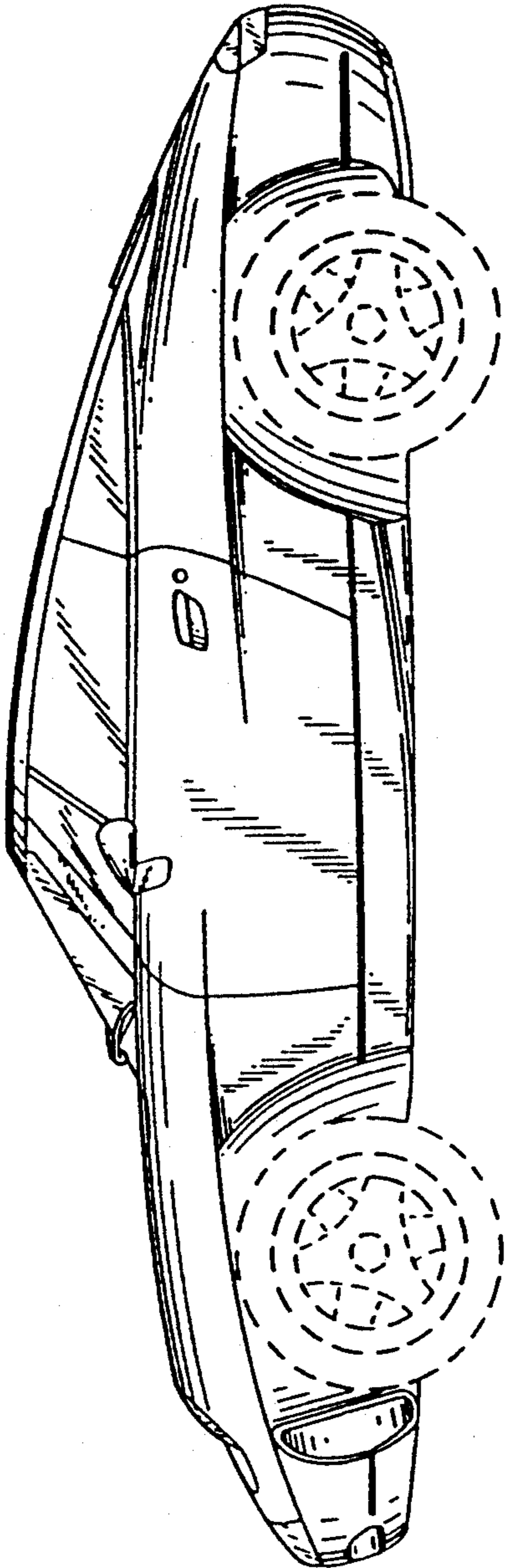

FIG. 4

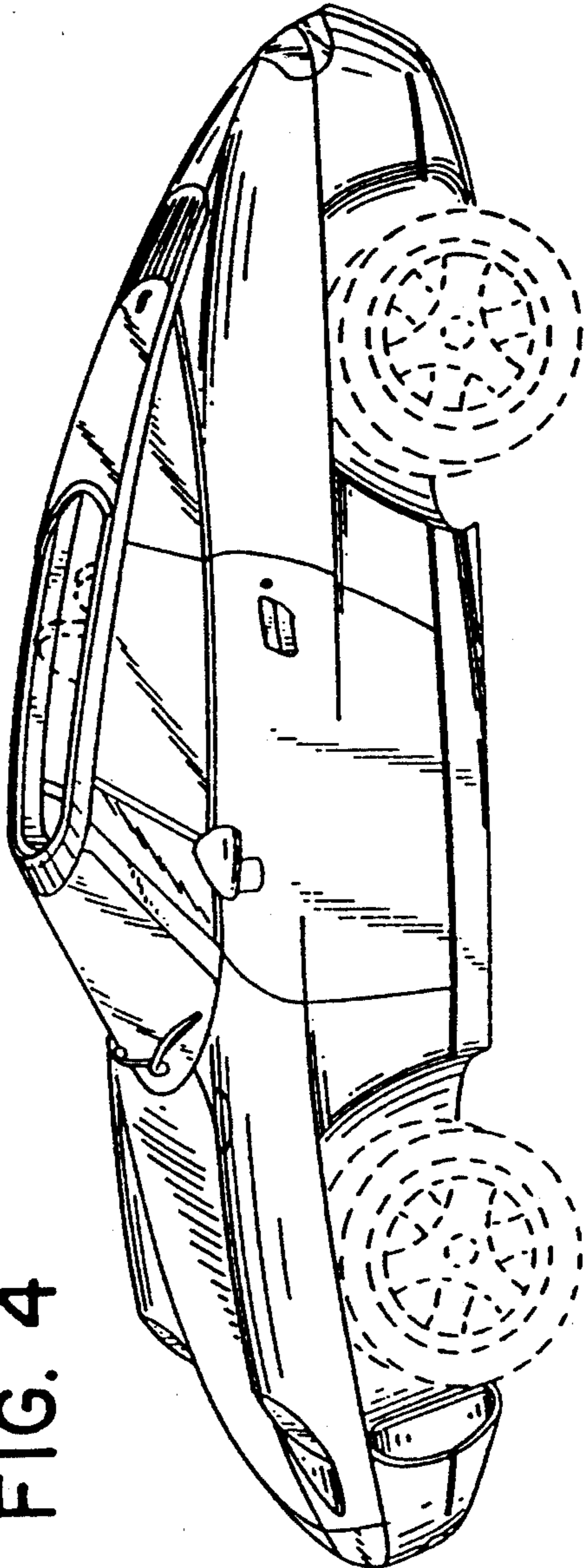

FIG. 5

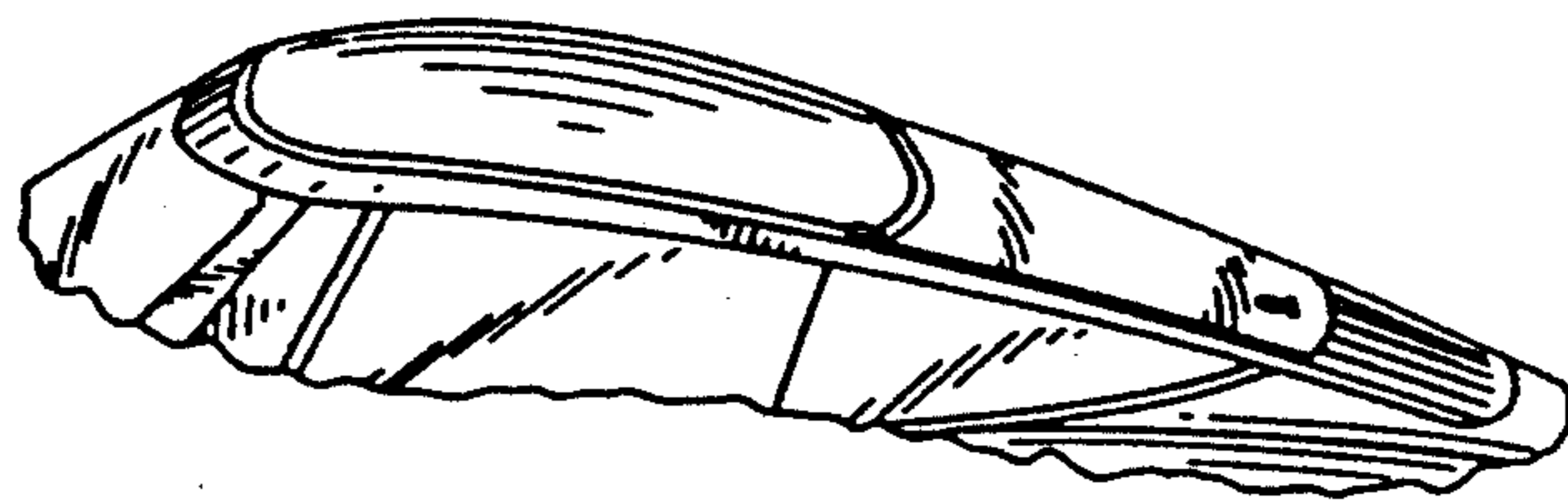

FIG. 6

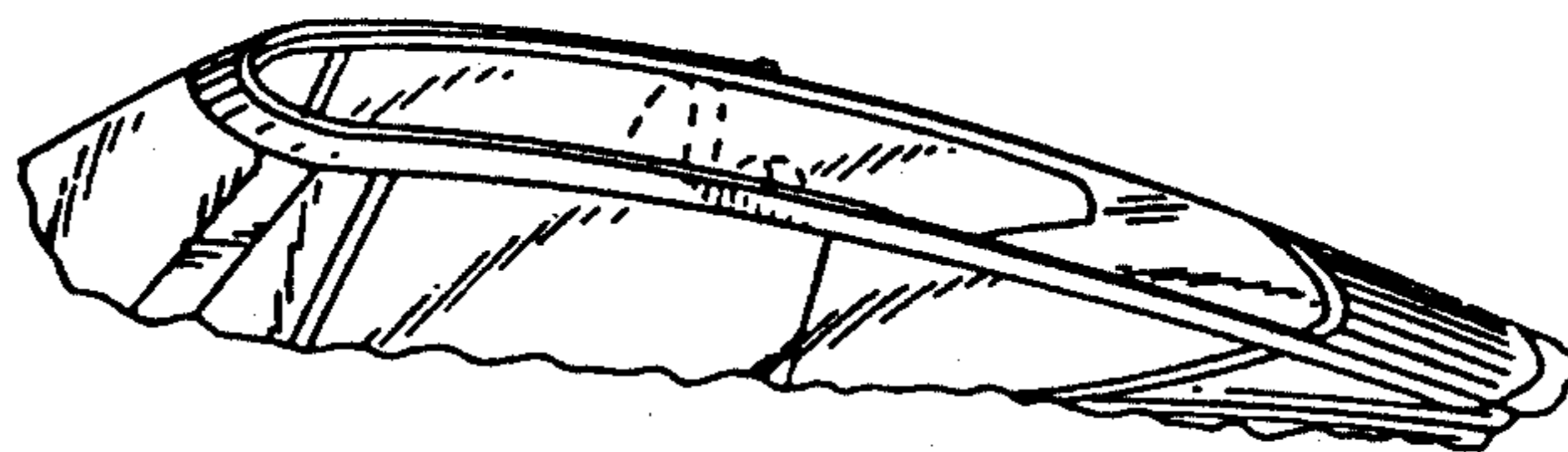

FIG. 7

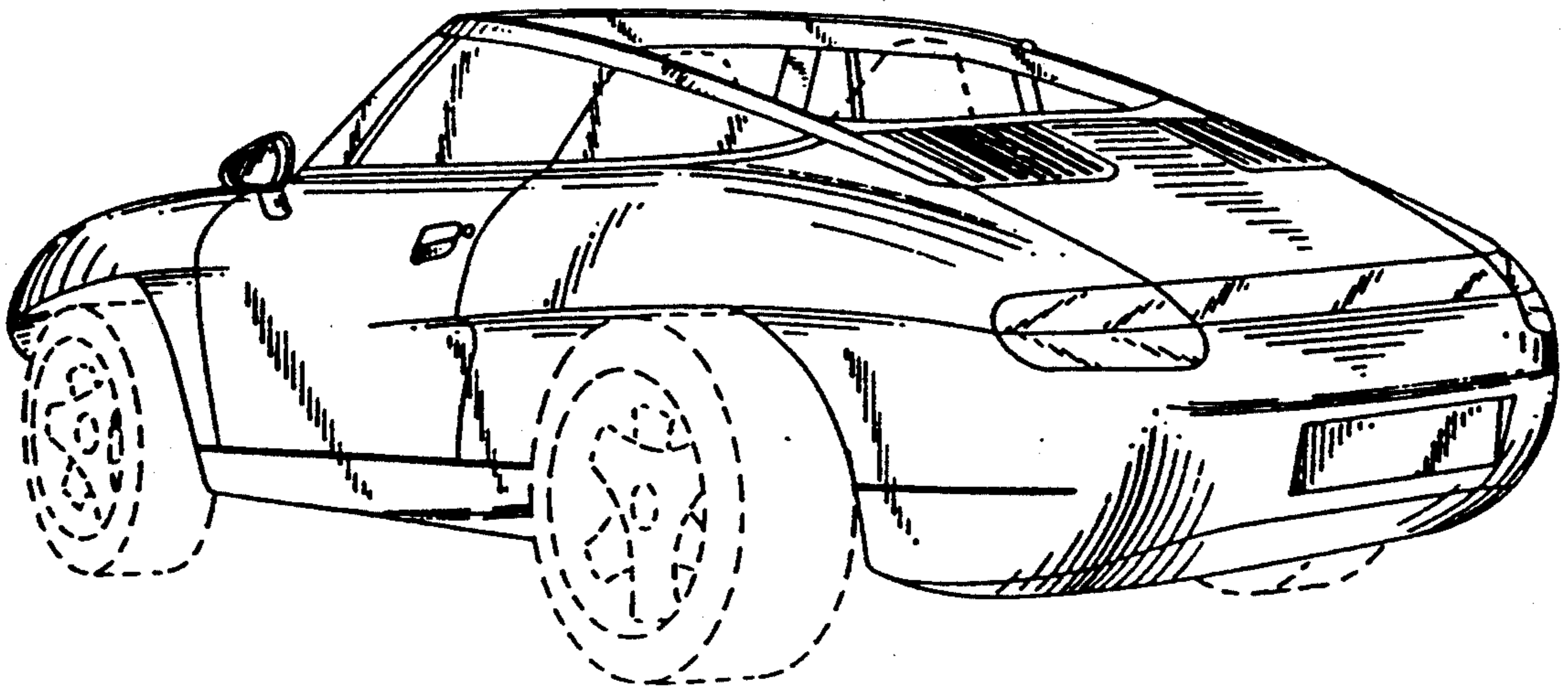

FIG. 8

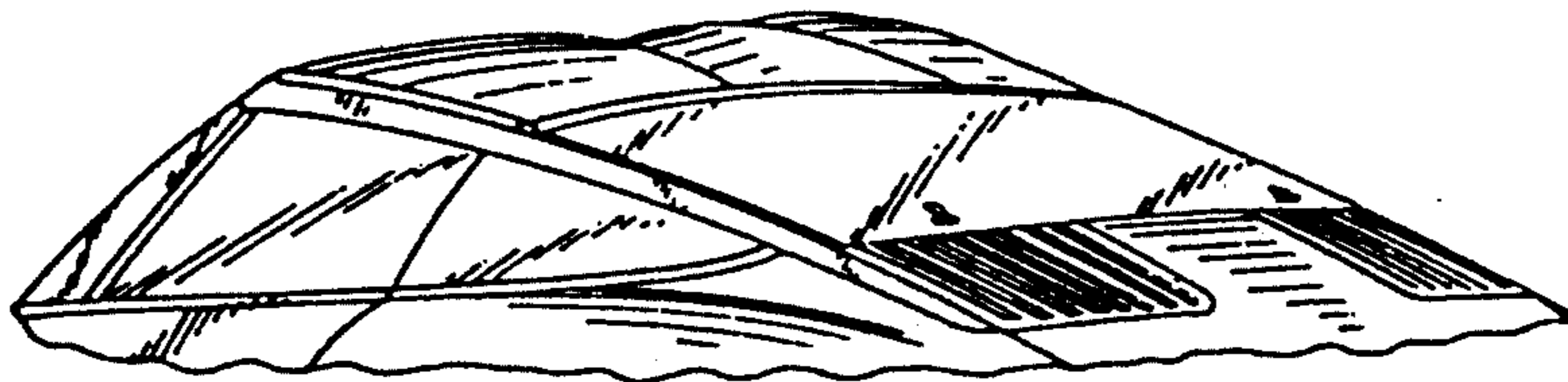

FIG. 9

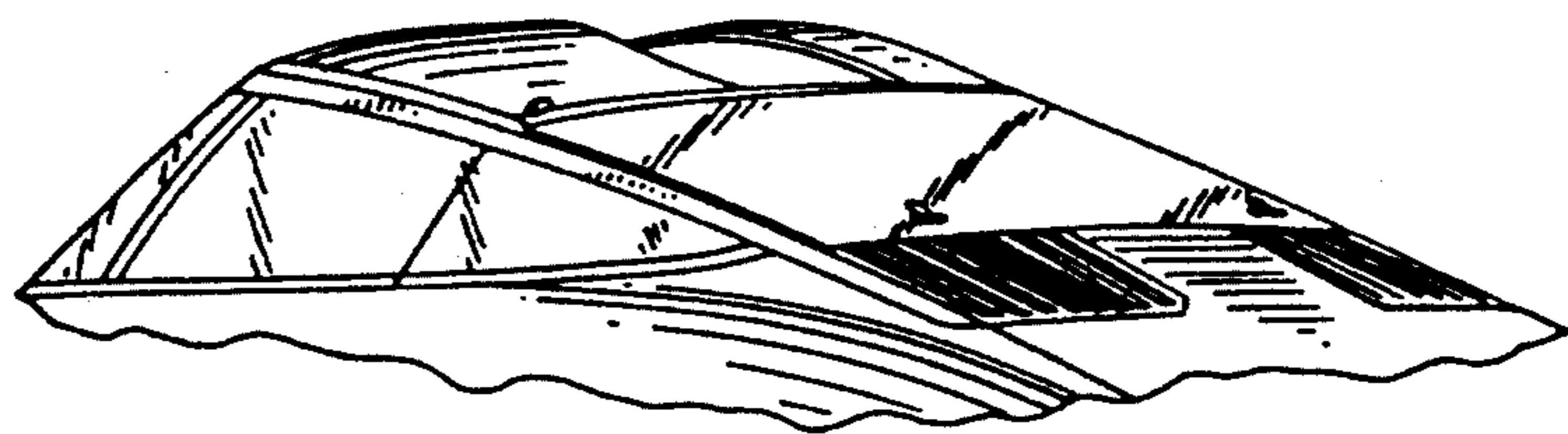

FIG. 10

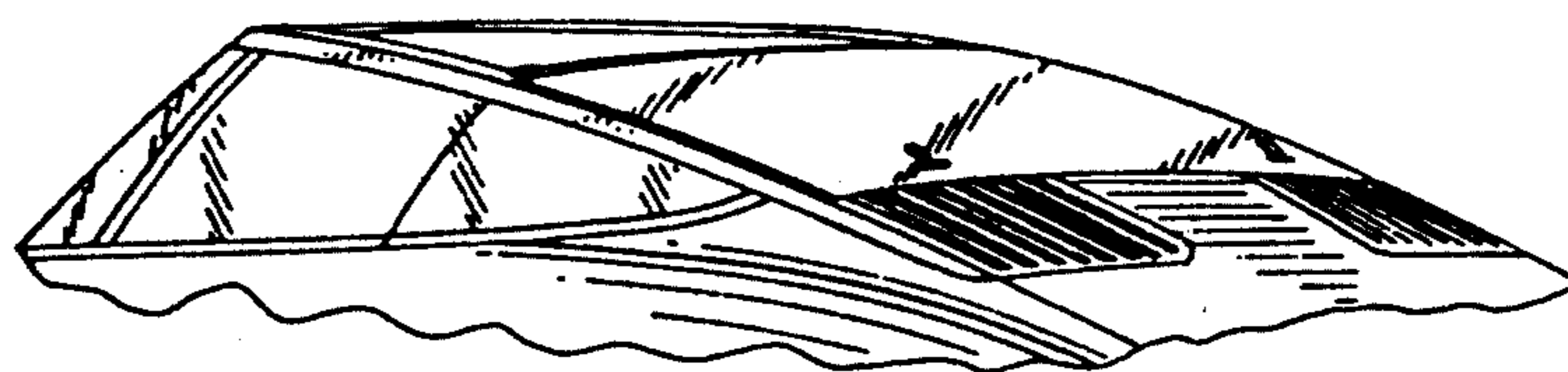

FIG. 11

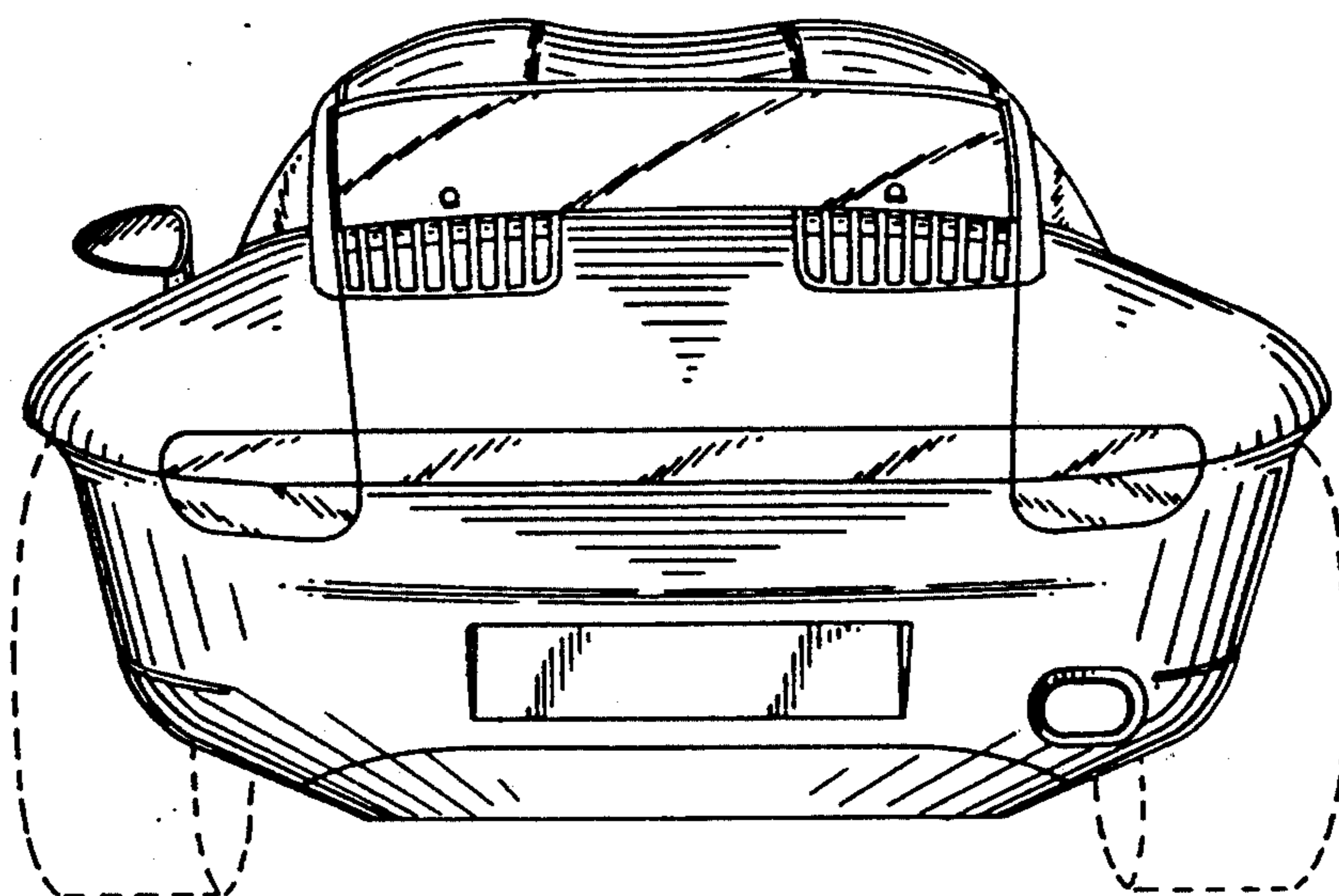

FIG. 12

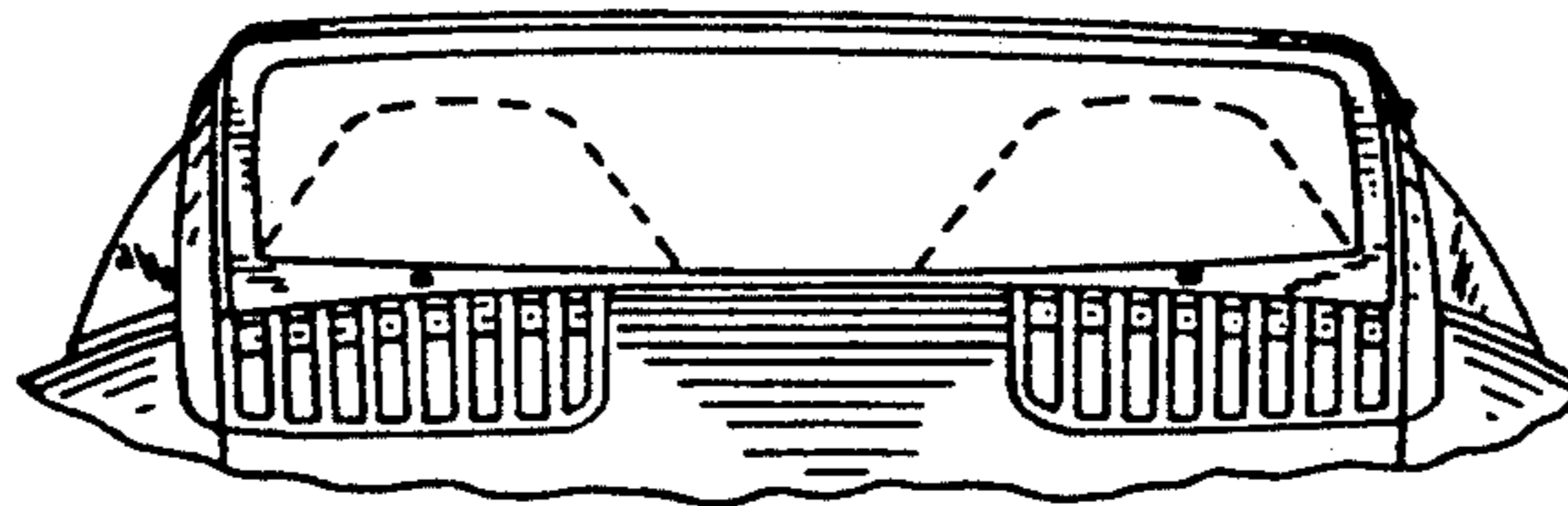

FIG. 13

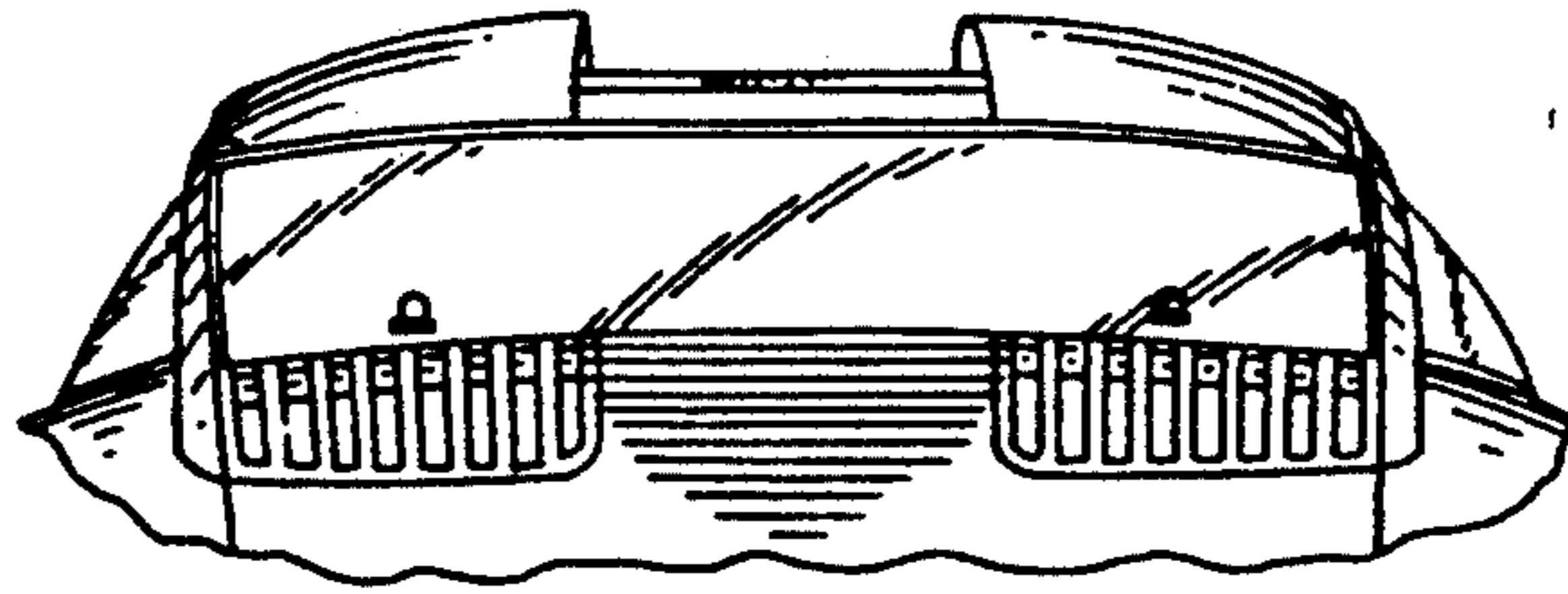

FIG. 14

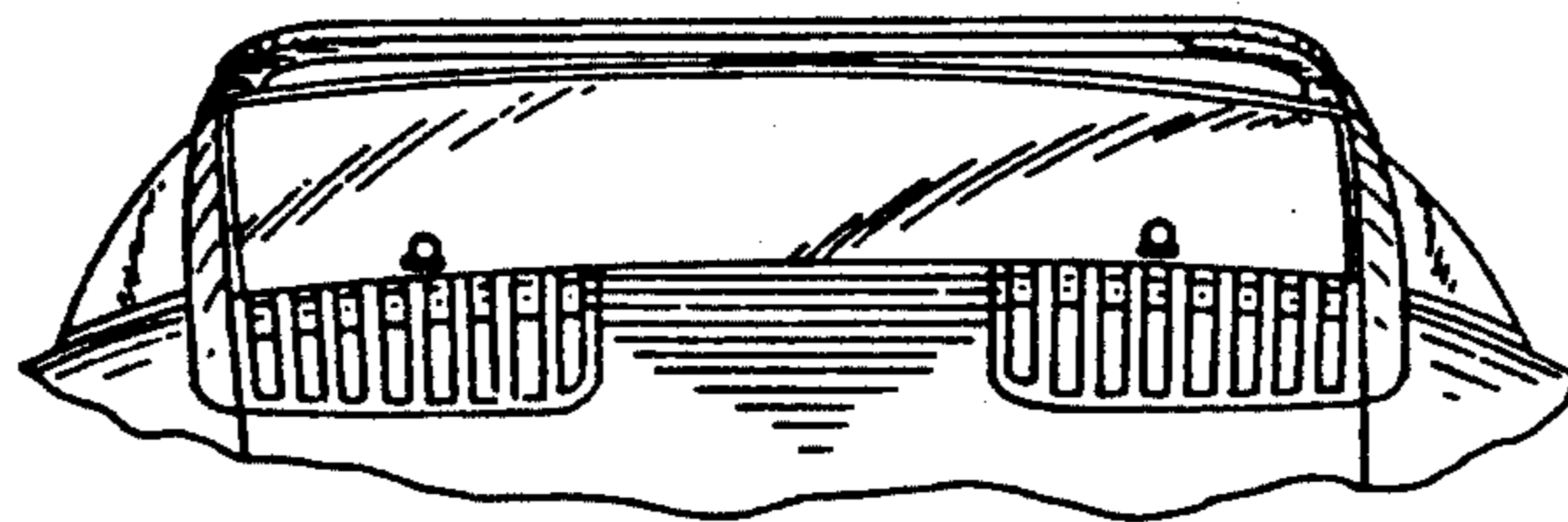

FIG. 15

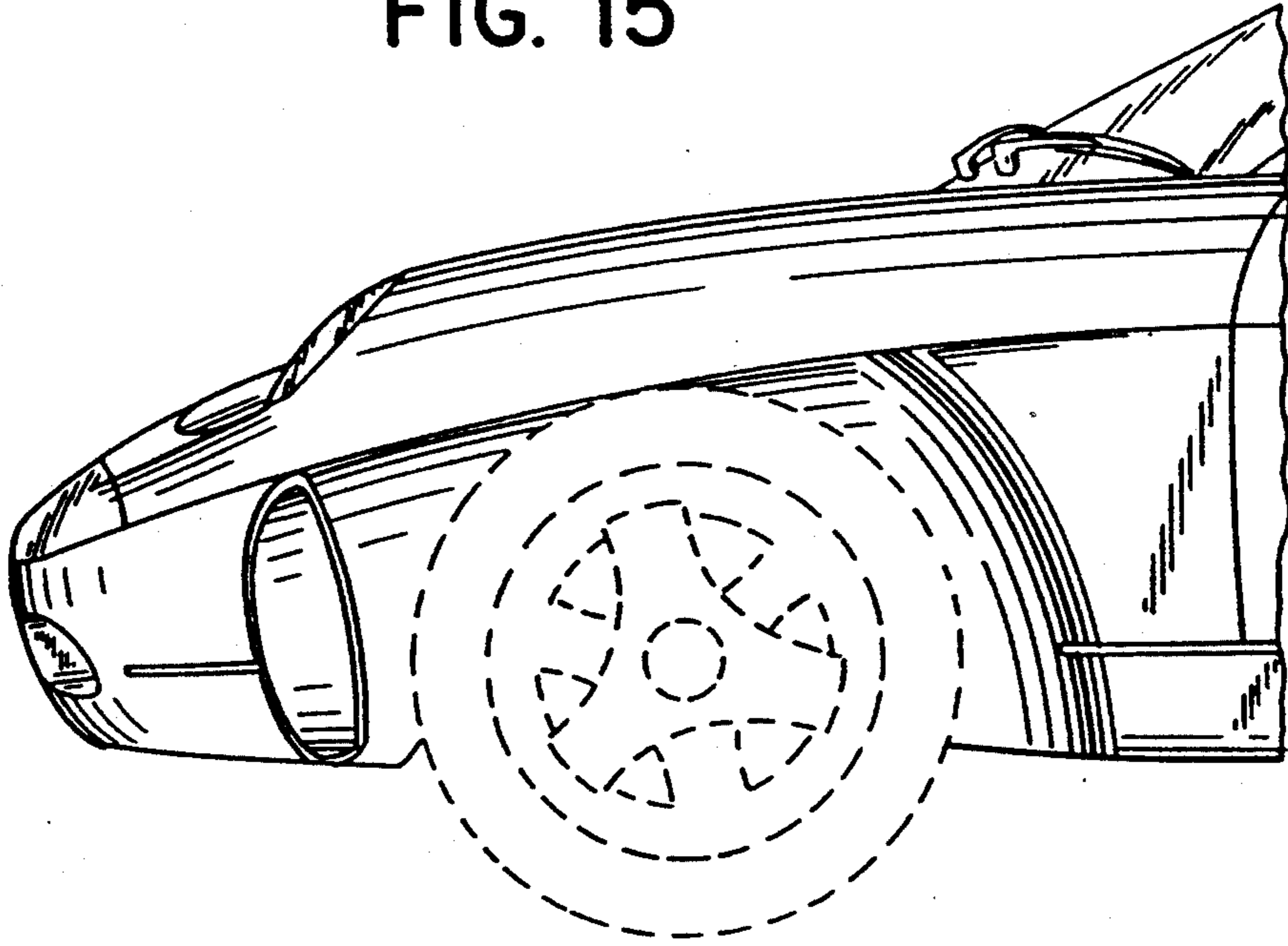

FIG. 16

